

# HP 71612 Series of Gb/s Testers

## Operating and Programming Manual

### SERIAL NUMBERS

This manual applies directly to HP 71612 12 Gb/s Error Performance Analyzers comprising the following elements:

- HP 70843**            Option UHF 0.1-12 Gb/s Error Performance Analyzer with serial number(s) prefixed 3xxxU or GBxxxxxxxx.
- HP 70843**            Option UHG 0.1-12 Gb/s Pattern Generator with serial number(s) prefixed 3xxxU or GBxxxxxxxx.
- HP 70843**            Option UHH Error Detector with serial number(s) prefixed 3xxxU or GBxxxxxxxx.

For additional important information about serial numbers, see SERIAL NUMBER INFORMATION on page 1-9 in the Operating Manual.

Serial number information for other elements in the system is contained in the following manuals:

- Display**            see HP 70004A Installation and Verification Manual.
- Mainframe**        see HP 70001A Installation and Verification Manual.
- Clock Source**     see HP 70340A/70341A Operating and Calibration Manual.

© Copyright (2000), Hewlett-Packard Ltd.



HP Part No. 71612-90011

Printed in U.K., March 2000

---

## Declaration of Conformity

according to ISO/IEC Guide 22 and EN45014

**Manufacturer's Name:** Hewlett-Packard Ltd.

**Manufacturer's Address:** Telecomms Networks Test Division  
South Queensferry  
West Lothian, EH30 9TG  
Scotland, United Kingdom

Declares that the product

**Product Name:** 12Gb/s Error Performance Analyzer System

**Model Number:** HP 71612B

**Product Options:** This declaration covers all options of the above product as detailed in TCF A-5951-9852-01

Conforms with the protection requirements of European Council Directive 89/336/EEC on the approximation of the laws of the member states relating to electromagnetic compatibility, against EMC test specifications EN 55011:1991 (Group 1, Class A) and EN 50082-1:1992.

**As Detailed in:** Electromagnetic Compatibility (EMC)  
Technical Construction File (TCF) No. A-5951-9852-01

**Assessed by:** DTI Appointed Competent Body  
EMC Test Centre,  
GEC-Marconi Avionics Ltd.,  
Maxwell Building,  
Donibristle Industrial Park,  
KY11 5LB  
Scotland, United Kingdom

Technical Report Number:6893/2200/CBR, dated 21 August 1997

### Supplementary Information:

The individual components of the product meet relevant international safety standards.

The product herewith complies with the requirements of the Low Voltage Directive 73/23/EEC, and carries the CE marking accordingly.

*South Queensferry, Scotland*

*15 December 1998*



*Location*

*Date*

*W.R. Pearson / Quality Manager*

Europe Contact:

Your Local Hewlett-Packard Sales and Service Office or Hewlett-Packard GmbH, Department 2Q / Standards Europe  
Herrenberger Strasse 130, D7030 Boblingen (Fax: +49-7031-143143)

## Declaration of Conformity

according to ISO/IEC Guide 22 and EN45014

**Manufacturer's Name:** Hewlett-Packard Ltd.

**Manufacturer's Address:** Telecomms Networks Test Division  
South Queensferry  
West Lothian, EH30 9TG  
Scotland, United Kingdom

Declares that the product

**Product Name:** 12Gb/s Bit Error Rate Tester

**Model Number:** HP 70843B

**Product Options:** This declaration covers all options of the above product as detailed in TCF A-5951-9852-01

Conforms with the protection requirements of European Council Directive 89/336/EEC on the approximation of the laws of the member states relating to electromagnetic compatibility, against EMC test specifications EN 55011:1991 (Group I, Class A) and EN 50082-1:1992.

**As Detailed in:** Electromagnetic Compatibility (EMC)  
Technical Construction File (TCF) No. A-5951-9852-01

**Assessed by:** DTI Appointed Competent Body  
EMC Test Centre,  
GEC-Marconi Avionics Ltd.,  
Maxwell Building,  
Donibristle Industrial Park,  
KY11 5LB  
Scotland, United Kingdom

Technical Report Number:6893/2200/CBR, dated 23 September 1997

### Supplementary Information:

The product conforms to the following safety standards:

EN 61010-1(1993)  
IEC 1010-1(1990) +A1(1992) +A2(1995)  
CSA-C22.2 No. 1010.1-93  
EN 60825-1(1994) / IEC 825-1(1993)

The product herewith complies with the requirements of the Low Voltage Directive 73/23/EEC, and carries the CE marking accordingly.

*South Queensferry, Scotland*

*15 December 1998*



*Location*

*Date*

*W.R. Pearson / Quality Manager*

Europe Contact:

Your Local Hewlett-Packard Sales and Service Office or Hewlett-Packard GmbH, Department 2Q / Standards Europe  
Herrenberger Strasse 130, D7030 Boblingen (Fax: +49-7031-143143)

## WARNINGS

The following general safety precautions must be observed during all phases of operation, service, and repair of this product. Failure to comply with these precautions or with specific warnings elsewhere in this manual violates safety standards of design, manufacture, and intended use of the product. Hewlett-Packard Company assumes no liability for the customer's failure to comply with these requirements.

This is a safety Class 1 instrument (provided with a protective earthing ground, incorporated in the power-cord). The mains plug shall only be inserted in a socket outlet provided with a protective earth contact. Any interruption of the protective conductor inside or outside of the instrument is likely to make the instrument dangerous. Intentional interruption is prohibited.

DO NOT operate the product in an explosive atmosphere or in the presence of flammable gasses or fumes.

For continued protection against fire hazard, replace the line fuses only with the same type and ratings (type nA/nV). The use of other fuses or materials is prohibited (where the fuse type is blown rate).

Keep away from live circuits: Operating personnel must not remove equipment covers or shields. Procedures involving the removal of covers and shields are for use by service-trained personnel only. Under certain conditions, dangerous voltages may exist even with the equipment switched off. To avoid dangerous electrical shock, DO NOT perform procedures involving cover or shield removal unless you are qualified to do so.

DO NOT operate damaged equipment: Whenever it is possible that the safety protection features built into this product have been impaired, either through physical damage, excessive moisture, or any other reason, REMOVE POWER and do not use the product until safe operation can be verified by service-trained personnel. If necessary, return the product to a Hewlett-Packard Sales and Service Office for service and repair to ensure the safety features are maintained.

DO NOT service or adjust alone: Do not attempt internal service or adjustment unless another person, capable of rendering first aid and resuscitation, is present.

DO NOT substitute parts or modify equipment: Because of the danger of introducing additional hazards, do not install substitute parts or perform any unauthorized modification to the product. Return the product to a Hewlett-Packard Sales and Service Office for service and repair to ensure the safety features are maintained.

If this instrument is not used as specified, the protection provided by the equipment could be impaired. This instrument must be used in a normal condition (in which all means of protection are intact) only.

No operator serviceable parts inside. Refer servicing to qualified personnel. To prevent electrical shock do not remove covers.

---

## **CERTIFICATION**

Hewlett-Packard Company certifies that this product met its published specifications at the time of shipment from the factory. Hewlett-Packard further certifies that its calibration measurements are traceable to the United States National Institute of Standards and Technology (formerly National Bureau of Standards), to the extent allowed by that organization's calibration facility, and to the calibration facilities of other International Standards Organization members.

## **WARRANTY**

This Hewlett-Packard product is warranted against defects in materials and workmanship for a period of one year from date of shipment. Duration and conditions of warranty for this product may be superseded when the product is integrated into (becomes part of) other HP products. During the warranty period, Hewlett-Packard Company will, at its option, either repair or replace products which prove to be defective.

For warranty service or repair, this product must be returned to a service facility designated by Hewlett-Packard (HP). Buyer shall prepay shipping charges to HP and HP shall pay shipping charges to return the product to Buyer. However, Buyer shall pay all shipping charges, duties, and taxes for products returned to HP from another country.

HP warrants that its software and firmware designated by HP for use with a product will execute its programming instructions when properly installed on that product. HP does not warrant that the operation of the product or software, or firmware will be uninterrupted or error free.

## **LIMITATION OF WARRANTY**

The foregoing warranty shall not apply to defects resulting from improper or inadequate maintenance by Buyer, Buyer-supplied products or interfacing, unauthorized modification or misuse, operation outside of the environmental specifications for the products, or improper site preparation or maintenance.

The design and implementation of any circuit on this product is the sole responsibility of the Buyer. HP does not warrant the Buyer's circuitry or malfunctions of HP products that result from the Buyer's circuitry. In addition, HP does not warrant any damage that occurs as a result of the Buyer's circuit or any other defects that result from Buyer-supplied products.

**NO OTHER WARRANTY IS EXPRESSED OR IMPLIED. HP SPECIFICALLY DISCLAIMS THE IMPLIED WARRANTIES OF MERCHANTABILITY AND FITNESS FOR A PARTICULAR PURPOSE**

## **EXCLUSIVE REMEDIES**

**THE REMEDIES PROVIDED HEREIN ARE BUYER'S SOLE AND EXCLUSIVE REMEDIES. HP SHALL NOT BE LIABLE FOR ANY DIRECT, INDIRECT, SPECIAL, INCIDENTAL, OR CONSEQUENTIAL DAMAGES, WHETHER BASED ON CONTRACT, TORT, OR ANY OTHER LEGAL THEORY.**

---

## NOTICE

The information contained in this document is subject to change without notice. HEWLETT-PACKARD (HP) MAKES NO WARRANTY OF ANY KIND WITH REGARD TO THIS MATERIAL, INCLUDING, BUT NOT LIMITED TO, THE IMPLIED WARRANTIES OF MERCHANTABILITY AND FITNESS FOR A PARTICULAR PURPOSE. HP shall not be liable for errors contained herein or for incidental or consequential damages in connection with the furnishing, performance or use of this material. This document contains proprietary information which is protected by copyright. All rights are reserved. No part of this document may be photocopied, reproduced, or translated without the prior written consent of the Hewlett-Packard Company. HP assumes no responsibility for the use or reliability of its software on equipment that is not furnished by HP.

## Restricted Rights Legend

Use, duplication or disclosure is subject to restrictions as set forth in subdivision (c)(1)(ii) of the Rights in Technical Data and Computer Software clause at 52.227-FAR14. Hewlett-Packard Company; 3000 Hanover Street; Palo Alto, California 94304.

## Printing History

The Printing History shown below lists all Editions and Updates of this manual and the printing date(s). The first printing of the manual is Edition 1. The Edition number increments by 1 whenever the manual is revised. Updates, which are issued between Editions, contain replacement pages to correct the current Edition of the manual. Updates are numbered sequentially starting with Update 1. When a new Edition is created, it contains all the Update information for the previous Edition. Each new Edition or Update also includes a revised copy of this printing history page. Many product updates or revisions do not require manual changes and, conversely, manual corrections may be done without accompanying product changes. Therefore, do not expect a one-to-one correspondence between product updates and manual updates.

<b>Edition or Update</b>	<b>Date</b>	<b>Part Number</b>		<b>Edition or Update</b>	<b>Date</b>	<b>Part Number</b>
Edition 1	Feb 1994	71612-90000		New Edition	Mar 2000	71612-90011
Edition 2	Jul 1995	71612.90000				
New Edition	Jun 1998	71612-90007				
New Edition	Dec 1998	71612-90008				

---

**HP 71612 Series of Gb/s Testers**  
**Operating Manual**







## 1 General Information

### Introduction 1-2

### Safety Considerations 1-2

Safety Information 1-2

General 1-3

Safety Symbols 1-4

### Options 1-6

Introduction 1-6

Upgrade Options 1-8

### Accessories Supplied 1-8

Recommended Accessory List 1-8

### Serial Number Information 1-9

### Returning Instruments for Service 1-9

Packaging Requirements 1-9

Preparing an Instrument for Shipping 1-10

### Precautions 1-11

ESD Precautions 1-11

Static-safe Workstation 1-11

Static-safe Accessories 1-12

Lifting/Carrying the HP 70843 1-12

Using one arm to lift instrument 1-12

Display Cleaning 1-13

Cabinet Cleaning 1-13

### How to Update the HP 70843 Firmware 1-13

To Update Control Processor Firmware 1-13

To Update Measurement Processor Firmware 1-14

## 2 Installation

### Introduction 2-2

### Preparation for Use 2-3

Initial Inspection 2-3

To Fit an Instrument Hardkey Panel 2-3

Statement of Compliance 2-4

Instruction for cleaning 2-4

Operating Requirements 2-4

Operating and Storage Environment 2-4

Physical Specifications 2-4

Cooling Considerations 2-5

Lifting the HP 70843 2-5

Power Requirements 2-5

Noise Declaration 2-6

Power Cables 2-6

## Contents - Operating Manual

Line Voltage Selection	2-7
Instrument (HP 70843) Line Voltage Selector	2-7
Display (HP 70004A) Line Voltage Selector	2-7
Mainframe (HP 70001A) Line Voltage Selector (HP 71612 options UHF/UKB and UHG/UKB only)	2-8
Line Fuses	2-9
Accessing the HP 70843 Line Fuse	2-9
Accessing the Display (HP 70004A) and Mainframe (HP 70001A) Fuses	2-9
Fuse Ratings	2-9
HP-MSIB Address Switches	2-10
Factory Preset HP-MSIB Addresses	2-10
HP 70843 Address Switches	2-10
HP 70340A Clock Source Module Address Switches	2-11
HP 70341A Clock Source Module Address Switches	2-11
HP 70004A Display Address Switches	2-12
HP-IB Address Switches	2-12
To Change the HP-IB Address	2-12
Factory Preset HP-IB Addresses	2-12
Bench Operation	2-13
Rack Mount Installation	2-13
<b>System Installation</b>	<b>2-14</b>
Accessories	2-14
Cables	2-14
Connectors	2-14
Terminations	2-14
Procedure	2-15
<b>System Verification</b>	<b>2-17</b>
Error Performance Analyzer System Verification	2-17
<b>Selftest at Power-on</b>	<b>2-18</b>
<b>Installing/Removing Modules</b>	<b>2-19</b>
Installing an HP 70340A Clock Source Module into a Display	2-19
Installing an HP 70341A Clock Source Module into a Mainframe	2-20

### 3 System Overview

#### Configurations 3-2

System Options	3-2
Additional System Options	3-3
HP 70843 Instrument Options	3-3
Documentation Overview	3-3

## 4 Operating Features and Specifications

### Introduction 4-2

Warm-up 4-2

Operating Temperature Specification 4-2

Calibration Interval 4-2

### Pattern Generator 4-3

External connections 4-3

### Patterns 4-3

PRBS Test Patterns 4-3

Zero Substitution/Variable Mark Density 4-3

Test Patterns 4-3

Zero Substitution 4-4

Variable Mark Density 4-4

User-programmable test patterns 4-4

Alternate test pattern - pattern generator only 4-4

Internal Disk Drive 4-5

### Clock Input 4-5

Features 4-5

Specifications 4-5

### Data and Data (inverted) Outputs 4-6

Features 4-6

Data output features not controlled by data output softkeys 4-6

Specifications 4-6

Data outputs - main 4-6

Error Add 4-8

### Clock and Clock (inverted) Outputs 4-8

Specifications 4-8

Clock outputs - main 4-8

### Subrate Clock & Data (inverted) Outputs 4-9

Features 4-9

Specifications 4-9

### Trigger Output 4-9

Features 4-9

Pattern Mode 4-10

PRBS  $2^{31}-1$ ,  $2^{23}-1$ ,  $2^{15}-1$ ,  $2^{10}-1$ ,  $2^7-1$  4-10

Alternate pattern 4-10

All other patterns 4-10

Divided Clock Mode 4-10

Interface 4-10

### Auxiliary Input 4-10

Alternate Pattern Selected 4-11

Data Output Inhibit (Gating mode) 4-11

## Contents - Operating Manual

Interface	4-11
To Select Oneshot Mode	4-11
To Select Alternating Mode	4-11
<b>Error Inject Input</b>	<b>4-12</b>
Interface	4-12
<b>Status Indicators</b>	<b>4-12</b>
Pattern Generator indicators	4-12
Error Detector indicators	4-12
General instrument indicators	4-12
<b>Rear Panel Switches</b>	<b>4-12</b>
<b>Error Detector</b>	<b>4-13</b>
External connections	4-13
<b>Clock Input (error detector)</b>	<b>4-13</b>
Features	4-13
Specifications	4-13
<b>Data Input</b>	<b>4-14</b>
Features	4-14
Specifications	4-14
<b>Pattern Trigger Output (error detector)</b>	<b>4-14</b>
Features	4-14
Pattern Mode	4-15
PRBS 2 <sup>31</sup> -1, 2 <sup>23</sup> -1, 2 <sup>15</sup> -1, 2 <sup>10</sup> -1, 2 <sup>7</sup> -1	4-15
All other patterns	4-15
Divided Clock Mode	4-15
Specifications	4-15
<b>Errors Output</b>	<b>4-15</b>
Features	4-15
Interface	4-15
<b>Gating Input</b>	<b>4-16</b>
Interface	4-16
<b>Automatic Clock-to-Data Alignment</b>	<b>4-17</b>
Introduction	4-17
Definition	4-17
Eye Width	4-17
Automatic 0/1 Threshold Center	4-18
To perform a 0/1 Threshold Centering	4-18
Data Input 0/1 Threshold	4-18
Introduction	4-18
<b>Measurements</b>	<b>4-18</b>
Error Analysis	4-19
Power-loss Seconds	4-19
Sync-loss Seconds	4-20
Frequency Measurement	4-20

## Contents - Operating Manual

Result Logging	4-20
<b>Error Location (HP 71612 or HP 70843 Option UHJ)</b>	<b>4-20</b>
Bit BER	4-20
Measurements	4-20
Error location capture	4-20
Block BER	4-21
<b>Measurement Period</b>	<b>4-22</b>
Measurement Period Features	4-22
Gating modes	4-22
Gating Period Definition	4-23
Burst gating	4-23
<b>Pattern Synchronization</b>	<b>4-24</b>
Synchronization Modes	4-24
Sync Gain Loss Criteria	4-24
Synchronization Times	4-24
<b>Audible Output</b>	<b>4-24</b>
<b>Logging to External Printer</b>	<b>4-25</b>
Functions	4-25
<b>To Set Up Your Own Display of Results or Status Information</b>	<b>4-25</b>
Procedure	4-25
Select and View the User's Page	4-25
To Build Your Own User's Page	4-26
<b>5 Getting Started</b>	
Using the HP 70004A Display	5-2
Key Notation	5-2
Display Fixed Label Keys	5-3
Instrument Hardkeys	5-3
Parameter Control Keys	5-3
Instrument Softkeys	5-3
Softkeys and Windows Color Coding	5-3
Multi-State Functions	5-3
To Set Up the Display	5-4
Display Functions	5-4
Instrument Functions	5-5
<b>System Turn-On</b>	<b>5-6</b>
Introduction	5-6
<b>Making Your First Measurement</b>	<b>5-7</b>
Introduction	5-7
Procedure	5-7
Initial Switch On	5-7
Initial settings	5-7

## Contents - Operating Manual

Perform a data eye measurement	5-8
Eye Edge Threshold	5-9
Automatic 0/1 Threshold Center	5-9
To Select a Measurement Gating Period	5-9
To Start a Measurement	5-9
Viewing Results and Introducing Errors into the System	5-9
To Select a Fixed Error Rate	5-10
To Add External Errors	5-10
Start a New Measurement	5-10
To View Measurement Results	5-10
<b>To Verify/Demonstrate the Capture Error Feature (Option UHJ instruments)</b>	<b>5-11</b>
Procedure	5-11

## 6 Softkey Menu Maps

### Introduction 6-2

Menu Map when MENU hardkey Selected	6-2
Menu Map when Result Pages hardkey Selected	6-3
Menu Map when Pattern hardkey Selected	6-3
PRBS Menu Map	6-4
Zerosub Menu Map	6-4
Markdensity Menu Map	6-5
Ram User Menu Map	6-5
Disk User Menu Map	6-6
Disk Utils Menu Map	6-6
Edit Ram User Menu Map	6-7
Edit Disk User Menu Map	6-7
Edit User Menu Map	6-8
Data Output Menu Map	6-8
Clock Output Menu Map	6-9
Error Add Menu Map	6-9
Subrate Outputs Menu Map	6-10
Trigger & Setup Menu Map	6-11
Miscellaneous Menu Map	6-12
Input & Eye Menu Map	6-12
Sync & Audio Menu Map	6-13
Gating Menu Map	6-14
Logging Menu Map	6-15
Error Location Menu Map	6-15
Build User Page Menu Map	6-16
Build User Page Pattern & Trigger Menu Map	6-16
Build User Page Data Output Menu Map	6-17

## Contents - Operating Manual

Build User Page Clock Output Menu Map	6-17
Build User Page Error Add Substrate Data/Clock Menu Map	6-18
Build User Page Input and Sync Menu Map	6-18
Build User Page Gating and Error Location Menu Map	6-19
Build User Page Logging Menu Map	6-19
Build User Page Main Results Menu Map	6-20
Build User Page Other Results Menu Map	6-20
Build User Page Interval Results Menu Map	6-21
Build User Page G.821 Results Menu Map	6-21
Build User Page Eye Results Menu Map	6-22
Build User Page Big Results Menu Map	6-22

## 7 Softkey Menu Descriptions

### Introduction 7-2

Softkey Menus 7-2

Softkeys requiring numeric entry 7-2

Softkey Labelling 7-2

Softkeys Color Coding 7-2

Primary Softkeys 7-3

Path Selection 7-3

### Pattern Softkey Menus 7-4

Path 7-4

Description 7-4

Edit User Pattern Menu (RAM or disk) 7-6

Path 7-6

Description 7-6

disk Utils 7-9

Path 7-9

Description 7-9

Alternate Pattern Control 7-9

Path 7-9

Description 7-9

### Data Output Menu 7-11

Path 7-11

Description 7-11

### Clock Output Menu 7-13

Path 7-13

Description 7-13

### Error Add Menu 7-14

Path 7-14

Description 7-14

**Subrate Outputs 7-15**

Path 7-15

Description 7-15

Subrate Data Softkeys 7-15

Subrate Clock Softkeys 7-15

**Trigger & Setup Menu 7-16**

Path 7-16

Description 7-16

Pattern Generator Trigger Output 7-16

Error Detector Trigger Output 7-17

Error Detector Errors Output 7-17

Save and Recall Instrument Setup 7-18

**Misc Menu 7-18**

Path 7-18

Description 7-18

**Result Pages Menu 7-20**

Path 7-20

Description 7-20

Main Results Display 7-20

Other Results Display 7-21

Interval Results 7-21

G.821 Results 7-22

Eye Results 7-22

User's Page 7-22

**Build User-Page Menu 7-23**

Path 7-23

Description 7-23

Pattern & Trigger USER'S PAGE menu 7-24

Data & Clock Output USER'S PAGE menus 7-24

Err-add Subrate USER'S PAGE menu 7-24

Input & Sync USER'S PAGE menu 7-25

Gating Err-loc USER'S PAGE menu 7-25

Logging USER'S PAGE menu 7-25

Main results USER'S PAGE menu 7-26

Other results USER'S PAGE menu 7-27

Interval results USER'S page menu 7-28

G.821 results USER'S PAGE menu 7-29

Eye results USER'S PAGE menu 7-29

BIG results USER'S PAGE menu 7-29

**Input & Eye Menu 7-30**

Path 7-30

Description 7-30



## Contents - Operating Manual

### **Sync & Audio Menu 7-32**

Path 7-32

Description 7-32

### **Gating Menu 7-33**

Path 7-33

Description 7-33

Gating after a Power Loss 7-33

### **Error Location 7-35**

Path 7-35

Description 7-35

### **Logging Menu 7-36**

Path 7-36

Description 7-36

## **8 User Patterns and Disk Operation**

### **Define, Edit and Store User Defined Patterns 8-2**

Introduction 8-2

Basic Editor Operation 8-2

The Editor 8-3

Editor Features 8-3

Pattern Stores 8-3

Current Pattern 8-3

Choosing a Pattern 8-4

RAM-Based File Catalog 8-4

Disk-Based File Catalog 8-4

User Pattern Memory 8-5

Exiting the Editor By Mistake 8-5

Procedure 8-5

### **How to Set Up and Edit Your Own User Pattern 8-6**

Introduction 8-6

To Edit User Patterns 8-6

Procedure 8-6

Set Pattern Length 8-7

Insert/Replace Bits in the Pattern 8-7

Delete Bits 8-7

To Save a Pattern 8-8

Procedure 8-8

To Load a Pattern Store Into the Editor 8-8

Procedure 8-8

To Load a PRBS or User Pattern into the Editor 8-9

## Contents - Operating Manual

To Load a Block of Data (PRBS)	8-9
Procedure	8-9
To Edit Zero Substitution	8-9
To Edit Mark Density	8-9
To Load a User Pattern Into the Editor	8-10
Procedure	8-10
Load Copies of User Patterns	8-10
To Save a Block of Data	8-11
Procedure	8-11
To Delete a Block of Data	8-12
Procedure	8-12
Alternate Patterns	8-12
To Select Alternate Pattern Control	8-13
Procedure	8-13
To Generate an Alternate Pattern	8-13
Procedure	8-13
To Load a $2^{10}$ PRBS into Half B of the Alternate Pattern	8-15
To Save the Alternate Pattern	8-15

### **Disk Operation 8-16**

Introduction	8-16
Running out of Disk Space	8-16
Unable to Write to Disk	8-17
Disk Organization	8-17
Header String Length	8-18
Header String	8-19
Revision Code	8-19
Pattern Index	8-20
Pattern Label String Length	8-20
Pattern Length	8-20
Trigger Bit	8-20
Type of Pattern	8-20
Pattern Contents	8-20

## **9 Preset Instrument Configurations**

### **Introduction 9-2**

PRESET Instrument Configurations	9-2
Preset 1 Configuration	9-8
Preset 2 Configuration	9-10

### **User Pattern Default Settings 9-11**

## 10 Data Logging

### Introduction 10-2

- Recommended Printers 10-2
- HP-IB (IEEE-488) to Centronics Printer Interface Converter 10-2
- Printer Interface Cables 10-3
- Printer Address 10-3
- Selecting Logging Functions 10-3
- To Log Results to an HP-IB External Printer 10-4
  - Connecting a Printer 10-4
  - To Log Results 10-4
- To Output Results via HP-IB to a Controller 10-4
  - Procedure 10-4
- When Measurement Results can be Logged 10-4
- Logging During Gating 10-5
  - Logging Trigger Threshold 10-5
  - Results Logged During Gating 10-5
- To Log Results During Gating 10-5
  - Procedure 10-5
- End of Measurement Period Logging 10-6
  - End of Measurement Logging Trigger 10-6
- To Log Results at the End of the Measurement Period 10-6
- Log On Demand 10-7
- Logging Alarms 10-7
  - To Log Alarms 10-7
- Logging Squelch 10-7
  - To Squelch or not to Squelch 10-7
- Results Storage 10-8
  - Results Storage when Logging is Switched On 10-8

## 11 Performance Tests

### Introduction 11-2

- Test Equipment Required 11-2
- Parametric Testing 11-3
  - Preliminary setup 11-3
- Data Risetime 11-4
- Data Falltime 11-4
- Data Jitter 11-5
- Data (inverted) Risetime 11-6
- Data (inverted) Falltime 11-6
- Data (inverted) Jitter 11-7
- Adjacent Bit-length Test 11-8
- Clock Risetime 11-8

## Contents - Operating Manual

Clock Falltime 11-8  
Clock (inverted) Risetime 11-9  
Clock (inverted) Faltime 11-9

### **Pattern Generator Tests 11-10**

Clock Input Minimum Level Alarm 11-10  
Clock Out and Clock (inverted) Out Amplitude and Frequency 11-11  
Data Out and Data (inverted) Out Amplitude 11-13  
Data Delay 11-15  
Pattern Generator Trigger Output 11-17  
Subrate Clock Out 11-18  
Parallel Data/4 Outputs 11-20  
Auxiliary Input (Alternate word switchover) 11-22  
Error Inject (internal and external) 11-23

### **Error Detector Performance Tests 11-25**

Clock Input Level Alarm 11-25  
Pattern Sync Output 11-26  
Gating Input & Error Measurement 11-27  
Error Out 11-27  
Audible Error Output 11-28  
Data 0/1 Threshold Auto/Manual Test 11-28  
Clock/Data Align 11-29  
Data Input Sensitivity 11-29

### **Pattern Verification 11-31**

Floppy Disk Read/Write 11-31  
Residual Error Rate Test 11-31

### **To Verify/Demonstrate the Capture Error Feature (Option UHJ instruments) 11-32**

**HP 70843 option UHF Line Final Test Data 11-33**

**HP 70843 Line Final Test Data 11-37**

## **12 Error Messages**

**Introduction 12-2**

**Non-Permanent Errors 12-3**

**Permanent Errors 12-9**

## **13 Troubleshooting**

**Entry Chart 13-2**

**System Indicators 13-3**

Error Indicators 13-4

**Volt/Temp Troubleshooting 13-5**

**HP-MSIB Troubleshooting 13-6**

- MMS Error Messages 13-8**
  - Error Reporting 13-8
- Clock Loss Troubleshooting 13-9**
  - Clock Source Output 13-9
- Data Loss Troubleshooting 13-9**
- Sync Loss and Errors Troubleshooting 13-10**
- Communication Troubleshooting 13-10**

## **14 Appendix A:**

### **Measurement Definitions**

#### **Measurement Definitions A-2**

- Error Measurements A-2
  - Error Count A-2
  - Delta Error Count A-2
  - Error Ratio A-2
  - Delta Error Ratio A-2
  - Errored Intervals A-2
  - Error Free Intervals A-2
- Error Analysis A-2
  - % Unavailability A-2
  - % Availability A-3
  - % Errored Seconds A-3
  - % Severely Errored Seconds A-3
  - % Degraded Minutes A-3
- Power Loss Seconds A-3
- Sync-loss Seconds A-3
- Error Location Analysis (Option UHJ instruments) A-3

## **15 Appendix B:**

### **Operating Notes**

#### **Setting Error Detector Sync Thresholds B-2**

- Introduction B-2
- Setting Sync Thresholds B-2
- Clock-to-Data Alignment Failure B-2

#### **Pattern Generation B-3**

- Introduction B-3

#### **Pattern Editor and Subrate Data B-4**

- Pattern Lengths Divisible By Four B-4
- Pattern Lengths Not Divisible By Four B-4
- Subrate Output Pattern Change with Trigger Bit Position B-4



---

**General Information**

## Introduction

This chapter contains general information about the HP 71612 Series System and is divided into the following sections:

<b>Safety Considerations</b>	General Safety Information, Safety Symbols
<b>Options</b>	Lists all the options available with your system.
<b>Accessories Supplied</b>	Lists the accessories supplied with your system.
<b>Serial Number Information</b>	Explains the Hewlett-Packard serial numbering system.
<b>Returning Instruments for Service</b>	Contains information on how to return an instrument to Hewlett-Packard for service.
<b>Precautions</b>	Highlights electrostatic discharge procedures and accessories available. This section also contains information on lifting or carrying the HP 70843 and on cleaning the display.
<b>Updating Firmware</b>	Provides a procedure for updating the HP 70843 firmware.

---

## Safety Considerations

This product is a Safety Class 1 instrument (provided with a protective earth terminal). The instrument and manual should be reviewed for safety markings and instructions before operation. Also read the Warnings page at the front of this manual.

## Safety Information

The following general safety precautions must be observed during all phases of operation, service, and repair of this instrument. Failure to comply with these precautions or with specific warnings elsewhere in this manual violates safety standards of design, manufacture, and intended use of the instrument. Hewlett-Packard Company assumes no liability for the customer's failure to comply with these requirements.

This is a Safety Class I instrument (provided with a protective earthing ground, incorporated in the powercord). The mains plug shall only be inserted in a socket outlet provided with a protective earth contact. Any interruption of the protective conductor inside or outside of the instrument is likely to make the instrument dangerous. Intentional interruption is prohibited.



**General Information**  
**Safety Considerations**

**General**

**DO NOT** operate the product in an explosive atmosphere or in the presence of flammable gasses or fumes.

**DO NOT** use repaired fuses or short-circuited fuseholders. For continued protection against fire, replace the line fuse(s) only with fuse(s) of the same voltage and current rating and type.

**DO NOT** perform procedures involving cover or shield removal unless you are qualified to do so. Operating personnel must not remove equipment covers or shields. Procedures involving the removal of covers and shields are for use by service-trained personnel only.

**DO NOT** service or adjust alone. Under certain conditions, dangerous voltages may exist even with the equipment switched off. To avoid dangerous electrical shock, service personnel must not attempt internal service or adjustment unless another person, capable of rendering first aid and resuscitation, is present.







**DO NOT** operate damaged equipment. Whenever it is possible that the safety protection features built into this product have been impaired, either through physical damage, excessive moisture, or any other reason, REMOVE POWER and do not use the product until safe operation can be verified by service-trained personnel. If necessary, return the product to a Hewlett-Packard Sales and Service Office for service and repair to ensure the safety features are maintained.

**DO NOT** substitute parts or modify equipment. Because of the danger of introducing additional hazards, do not install substitute parts or perform any unauthorized modification to the product. Return the product to a Hewlett-Packard Sales and Service Office for service and repair to ensure the safety features are maintained.



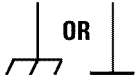

**General Information**  
**Safety Considerations**

**Safety Symbols**

The following symbols on the instrument and in the manual indicate precautions which must be taken to maintain safe operation of the instrument.

	The Instruction Documentation Symbol. The product is marked with this symbol when it is necessary for the user to refer to the instructions in the supplied documentation.
	Indicates the field wiring terminal that must be connected to earth ground before operating the equipment - protects against electrical shock in case of fault.
	Frame or chassis ground terminal - typically connects to the equipment's metal frame.
	Alternating current (ac)
	Direct current (dc)
	Indicates hazardous voltages
<b>WARNING</b>	Warning denotes a hazard. It calls attention to a procedure, which if not correctly performed or adhered to could result in injury or loss of life. Do not proceed beyond a warning note until the indicated conditions are fully understood and met.
<b>CAUTION</b>	Caution denotes a hazard. It calls attention to a procedure, which if not correctly performed or adhered to could result in damage to or destruction of the instrument. Do not proceed beyond a warning note until the indicated conditions are fully understood and met.
	The CE mark shows that the product complies with all relevant European legal Directives.

**General Information**  
**Safety Considerations**

<b>ISM 1-A</b>	This is a symbol of an Industrial Scientific and Medical Group 1 Class A product.
	The CSA mark is a registered trademark of the Canadian Standards Association. Indicates a functional earth terminal.
	Indicates a functional earth terminal.
	The recycling symbol.
	The dispose of properly symbol.

## Options

### Introduction

The HP 12 Gb/s BERT products offer a range of product options to suit user applications. There are two standard core products (HP 71612 and HP 70843) each having a set of user options. The core products cannot be ordered or supplied on their own; they must be ordered with an option. They are as follows:

- HP 71612: comprises an HP 70004A display and an HP 70843 product base.
- HP 70843: comprises a Hewlett-Packard MMS system II cabinet with PSU and control hardware/firmware functions for a BERT, pattern generator or error detector option. HP 70843 options are provided for users who may not require an HP 70004A display or who wish to operate the instrument remotely via HP-IB.

The following tables list the options available for the HP 71612 and HP 70843 core products.

### HP 71612 Options

Product	Option	Description	Elements Included			
			Display	Pattern Generator	Error Detector	Clock Source
71612	UHF	12 Gb/s error performance analyzer (BERT)	yes	yes	yes	yes
71612	UHG	12 Gb/s pattern generator	yes	yes	no	yes
71612	UHH	12 Gb/s error detector system	yes	no	yes	no

**General Information  
Options**

**HP 71612 Options continued**

Product	Option	Description	Elements Included	
			Mainframe	Clock Source Extension Module
71612	UKB	extend lowest frequency to 0.1 Gb/s	yes	yes
71612	UHJ	add error location analysis to option UHF or UHH		
71612	UKC	delete clock source from option UHF or UHG		
71612	OB1	extra set of HP 71612 manuals		
71612	1CM	rack mount kit; for instrument without handles fitted		
71612	1CP	rack mount kit; for instrument with handles fitted		

**HP 70843 Options**

Product	Option	Description	Elements Included			
			Display	Pattern Generator	Error Detector	Clock Source
70843	UHF	12 Gb/s error performance analyzer (BERT)	no	yes	yes	no
70843	UHG	12 Gb/s pattern generator	no	yes	no	no
70843	UHH	12 Gb/s error detector	no	no	yes	no
70843	UHJ	add error location analysis to option UHF or UHH				
70843	OB1	extra set of HP 71612 manuals				
70843	1CM	rack mount kit; for instrument without handles fitted				
70843	1CP	rack mount kit; for instrument with handles fitted				

**General Information**  
**Accessories Supplied**

## Upgrade Options

The following options upgrade HP 71612 and HP 70843 option UHG pattern generators and option UHH error detectors to full BERT capability. Both upgrades can only be carried out at the manufacturing division.

### HP 15807A Factory Upgrade to 12 Gb/s BERT

Product	Option	Description
15807A	001	add pattern generator
15807A	002	add error detector

---

## Accessories Supplied

The accessories supplied with your system are listed below:

- Two HP-MSIB cables.
- Line power cable. (3 off when an HP 70001A mainframe is supplied.)
- 8 mm hex-ball driver.
- 4 off SMA to SMA test cables.
- 1 off N-SMA adapter.
- 5 off APC-3.5 mm connector savers.
- 2 off APC-3.5 mm male-female adapter.
- 7 off 50Ω SMA terminations.

## Recommended Accessory List

The following items are not supplied with your instrument but are recommended accessories.

- APC-3.5 mm cables.
- APC-3.5 mm attenuators.
- APC-3.5 mm 50Ω terminations.
- Torque wrench for APC-3.5 mm.

## Serial Number Information

Attached to each element in your system is a serial number plate. A typical serial number is in the form XXXXUXXXXX. It is in two parts; the first four digits and the letter are the serial prefix and the last five are the suffix, the letter designates the country of origin - U is the United Kingdom. The prefix is the same for identical elements, it only changes when a change is made to an element in your system. The suffix however, is assigned sequentially and is different for each element. The contents of this manual apply to the elements with the serial number prefix(es) listed under **SERIAL NUMBERS** on the title page.

A system manufactured after the printing of this manual may have a number prefix that is not listed on the title page. The unlisted serial number prefix indicates the system is different from those described in this manual. The manual for this new element is accompanied by a **Manual Changes** supplement. This supplement contains **change information** that explains how to adapt the manual to the new element.

In addition to change information, the supplement may contain information for correcting errors in the manual. To keep this manual as current and accurate as possible, Hewlett-Packard recommends that you periodically request the latest Manual Changes supplement. The supplement for this manual is identified with the manual print date and part number, both of which appear on the manual title page. Complementary copies of the supplement are available from Hewlett-Packard. For information concerning a serial number prefix that is not listed on the Manual Changes supplement, contact your nearest Hewlett-Packard office.

---

## Returning Instruments for Service

This section explains how you return an instrument to Hewlett-Packard for servicing.

## Packaging Requirements

Instruments can be damaged as a result of using packaging materials other than those specified. Never use styrene pellets as packaging material. They do not adequately cushion the instrument nor prevent it from shifting in the carton. They also cause instrument damage by generating static electricity.

**General Information**  
**Returning Instruments for Service**

## **Preparing an Instrument for Shipping**

1. Fill out a blue repair tag (located at the front of this manual) and attach it to the instrument. Include any error messages or specific performance data related to the problem. If a blue tag is not available, the following information should be noted and sent with the instrument:
  - Type of service required.
  - Description of the problem.
  - Whether problem is constant or intermittent.
  - Name and phone number of technical contact person.
  - Return address.
  - Model number of returned instrument.
  - Full serial number of returned instrument.
  - List of any accessories returned with the instrument.
2. Pack the instrument in the appropriate packaging materials. Original shipping or equivalent materials should be used. If the original or equivalent material cannot be obtained, follow the instructions below:

---

**CAUTION** Inappropriate packaging of the instrument may result in damage to the instrument during transit.

---

- Wrap the instrument in anti-static plastic to reduce the possibility of damage caused by ESD.
- Use a double-walled, corrugated cardboard carton of 159 kg (350 lb) test strength.

---

**CAUTION** If you are shipping a complete system, remove the module(s) from Display and Mainframe, individually pack each element, then ship them to Hewlett-Packard.

---

- The carton must be large enough to allow 3 to 4 inches on all sides of the instrument for packing material and strong enough to accommodate the weight of the instrument.
  - Surround the instrument with 3 to 4 inches of packing material, to protect the instrument and prevent it from moving in the carton.
  - If packing foam is not available, the best alternative is S.D.-240 Air Cap™ from Sealed Air Corporation (Commerce, California 90001). Air Cap™ looks like a plastic sheet filled with air bubbles.
  - Use the pink (anti-static) Air Cap™ to reduce static electricity. Wrapping the instrument several times in this material will protect the instrument and prevent it from moving in the carton.
3. Seal the carton with strong nylon adhesive tape.
  4. Mark the carton **FRAGILE, HANDLE WITH CARE**.
  5. Retain copies of all shipping papers.



---

## Precautions

### ESD Precautions

Electrostatic discharge (ESD) can damage or destroy electronic components. All work on electronic assemblies should be performed at a static-safe workstation.

---

**NOTE** When the instrument is subjected to air discharges above 2 kV, as detailed in standard IEC 1000-4-2 (1995), degradation in performance may be observed in the form of bit errors.

---

### Static-safe Workstation

A typical static-safe workstation is illustrated in the following diagram. There are two types of ESD protection:

- Wrist-strap (with  $>1\text{ M}\Omega$  isolation to ground) with table mat.
- Heel-strap (with  $>1\text{ M}\Omega$  isolation to ground) with conductive floor mat.

These two types must be used together to ensure adequate ESD protection. Isolation to ground must be provided for personnel protection.

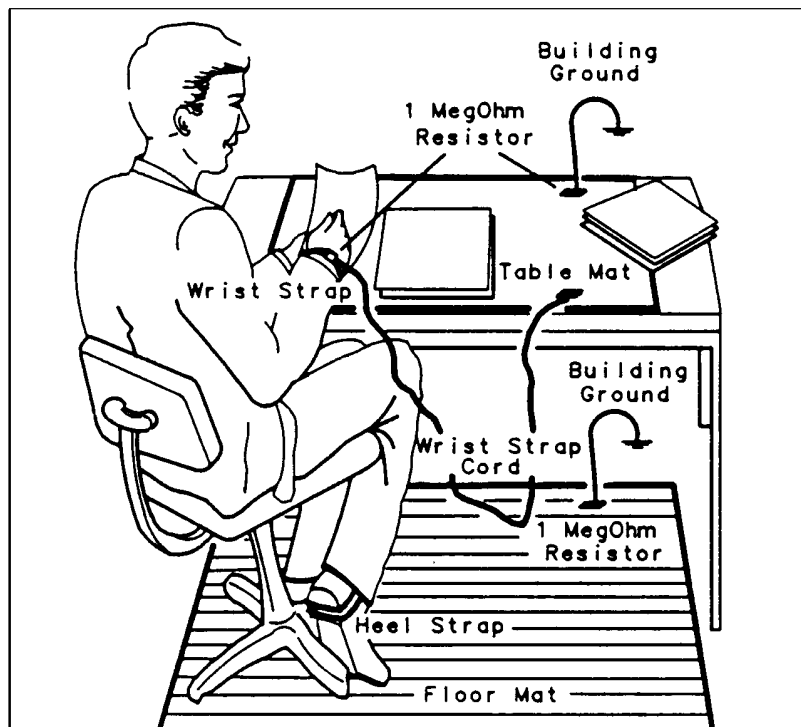

**General Information**  
**Precautions**

### **Static-safe Accessories**

The following table lists the accessories that may be ordered through any Hewlett-Packard sales and service office.

<b>HP Part Number</b>	<b>Description</b>
9300-0797	3M static control mat 0.6 m x 1.2 m (2 ft x 4 ft) and 4.6 m (15 ft) of ground wire. (The wrist-strap and wrist-strap cord are not included. They must be ordered separately.)
9300-0980	Wrist-strap cord 1.5 m (5 ft).
9300-1383	Wrist-strap, color black, stainless steel, has four adjustable links and a 7 mm post-type connection.
9300-1169	ESD heel-strap (reusable 6 to 12 months).
*92175A	Black, hard surface, static control mat, 1.2 m x 1.5 m (4 ft x 5 ft)
*92175B	Brown, soft surface, static control mat, 1.2 m x 2.4 m (4 ft x 8 ft)
*92175C	Small, black, hard surface, static control mat, 0.9 m x 1.2 m (3 ft x 4 ft)
*92175T	Table-top static control mat, 58 cm x 76 cm (23 in x 30 in)
*92176A	Natural color anti-static carpet, 1.2 m x 1.8 m (4 ft x 6 ft)
*92176B	Natural color anti-static carpet, 1.2 m x 2.4 m (4 ft x 8 ft)
*92176C	Russet color anti-static carpet, 1.2 m x 1.8 m (4 ft x 6 ft)
*92176D	Russet color anti-static carpet, 1.2 m x 2.4 m (4 ft x 8 ft)

\*Can also be ordered by calling HP DIRECT Phone (800) 538 8787.

### **Lifting/Carrying the HP 70843**

Use the handle on the side of the instrument for lifting the HP 70843. Before attempting to lift or carry the instrument consider the following basic lifting techniques to help avoid personal injury.

#### **Using one arm to lift instrument**

- BRACE your body with the opposite arm, if possible.
- Reach for the instrument - bend your knees and waist, and keep your back straight.
- GRASP the instrument firmly - using the handle.
- LIFT with your legs, using the free arm for balance.
- KEEP your shoulders level - switch hands regularly.

## Display Cleaning

To avoid damaging the coating on the display, use a thin-film cleaner such as Hewlett-Packard Video Clean Kit (HP part number 92193). The kit includes a non-abrasive cleaning cloth.

---

**CAUTION** Hand and laboratory paper towels are abrasive, if these are used they may damage the coating on the display.

---

## Cabinet Cleaning

To clean the instrument cabinet: Use a soft, clean cloth to clean the front-panel and side covers.

---

## How to Update the HP 70843 Firmware

---

**CAUTION** Do not attempt to update instrument firmware unless advised by Hewlett-Packard and supplied with an appropriate firmware update disk.

---

The HP 70843 has two processor systems, a Control Processor and a Measurement Processor. The firmware for either processor can be updated using the instrument floppy disk drive. The first part of the update process is as follows:

1. Power up instrument and HP 70004A display.
2. Press **USER** key on HP 70004A display under screen.
3. Press **misc** softkey (bottom left-hand softkey).
4. Insert firmware update disk into instrument.
5. Press **update firmware** softkey.

Now either update the Control Processor or Measurement Processor:

### To Update Control Processor Firmware

1. Press **UpdCntlAppl**.
2. Confirm operation by pressing **UPDATE YES** softkey (top left-hand). Wait for update to complete - this can take several minutes. During the update the HP-IB indicator LEDs light from left to right and the end of a successful update is indicated by the green MSIB ACT LED flashing. If the update is unsuccessful the red MSIB ERR LED flashes.
3. Power cycle.

**General Information**  
**How to Update the HP 70843 Firmware**

### **To Update Measurement Processor Firmware**

1. Press **UpdMeasAppl**.
2. Confirm operation by pressing **UPDATE YES** softkey (top left-hand).
3. Wait for update to complete, at the end of the update a message will appear at the bottom of the screen requesting a power cycle.
4. Power cycle.

---

## **Installation**

## Introduction

This chapter enables you to install your system ready for use. The information is presented under the following headings:

<b>Preparation for Use:</b>	Provides information you should read before you install your system. It contains information on initial inspection, power requirements, address switches and rack mount kits.
<b>System Installation:</b>	Shows you how to install your system. As you progress through the procedure, you will be directed to other relevant information.
<b>System Verification:</b>	Describes how you power-on and verify correct system installation.
<b>Selftest at Power-on:</b>	Details the instrument status during selftest at power-on.
<b>Installing/Removing Modules:</b>	Describes how you install a clock source module into a Display and Mainframe.

---

<b>WARNING</b>	<b>If this instrument is not used as specified, the protection provided by the equipment could be impaired. This instrument must be used in a normal condition only (in which all means for protection are intact).</b>
----------------	---

---

## Preparation for Use

This section should be read before you install your system. It contains the following:

- Initial Inspection
- Operating Requirements
- Line Voltage Selection
- Line Fuses
- Power Cables
- HP-MSIB Address Switches
- HP-IB Address Switches
- Bench Operation
- Rack Mount Kits

## Initial Inspection

---

**WARNING** To avoid hazardous electrical shock, do not perform electrical tests when there are signs of shipping damage to any portion of the outer enclosure (covers, panels, meters).

---

Inspect the shipping container for damage. If the shipping container or cushioning material is damaged, it should be kept until the contents of the shipment have been checked for completeness and the elements in your system have been checked both mechanically and electrically. Procedures for checking the electrical operation are given starting on page 11-1 of this manual.

If any element in your system appears damaged or is defective, contact the nearest Hewlett-Packard service office. Hewlett-Packard will arrange for repair or replacement of the equipment without waiting for a claim settlement. Retain the shipping materials for the carrier to inspect.

Undamaged shipping materials should be kept. Original HP or equivalent shipping materials are required for system or module re-shipment, as substandard packaging may result in damage. Refer to *Returning Instruments for Service* on page 1-9 for information on re-shipment.

## To Fit an Instrument Hardkey Panel

On all HP 71612 systems, the instrument hardkey panel is fitted to the display at the factory. For HP 70843 orders where the user already has an HP 70004A display, refer to

## Installation Preparation for Use

page 2-11 of the HP 70004A Display Installation and Verification manual (part number 70004-90005) for advice on fitting the instrument hardkey panel.

### Statement of Compliance

This instrument has been designed and tested in accordance with IEC Publication 1010-1+A1:1992 Safety requirements for Electrical Equipment for Measurement, Control and Laboratory Use, and has been supplied in a safe condition. The instruction documentation contains information and warnings which must be followed by the user to ensure safe operation and to maintain the instrument in a safe condition.

### Instruction for cleaning

To clean the instrument cabinet: Use a soft, clean damp cloth to clean the front-panel and side covers.

### Operating Requirements

#### Operating and Storage Environment

This instrument is designed for Indoor use only.

The module may be operated at temperatures from 5°C to 35°C at altitudes up to 3,000 m (10,000 ft.) The module may be operated in environments up to 95% relative humidity to 40°C, but it should be protected from temperature extremes which may cause condensation. To ensure adequate cooling do not obstruct air vents in the instrument cabinet.

---

**CAUTION** This instrument is designed for use in Installation Category II and Pollution Degree 2 per IEC 1010 and 644 respectively.

---

### Physical Specifications

The physical dimensions and weight of each element in your system are as follows:

**Table 2-1**

**Dimensions and weight**

Dimensions & Weight	HP 70843	HP 70004A + HP 70340A
Height	223 mm	223 mm
Width	426 mm	426 mm
Depth	500 mm	500 mm
Weight	<30 kg	<30 kg



## Installation Preparation for Use

### Cooling Considerations

The HP 70843 12 Gb/s BERT will operate at up to 40°C ambient temperature but optimum performance is obtained close to 25°C ambient temperature.

In use it is important to make sure there is no obstruction to airflow through the instrument. Cooling air is taken in on the right-hand side and is blown out through the left-hand side of the instrument, looking from the front. If this airflow is obstructed the performance and reliability of the instrument will be reduced.

In the rack-mounted system it is particularly important to make sure the airflow is not obstructed. For example, cables in the side of the racks can obstruct the airflow. Also make sure the input air temperature is not increased above 40°C by other instruments in the rack. If forced ventilation is used in a rack the air pressure on both sides of the instrument must be the same for the instrument cooling to operate correctly.

### Lifting the HP 70843

Use the handles on the side of the instrument for lifting or carrying the HP 70843. Before attempting to lift or carry the instrument consider the following basic lifting techniques to help avoid personal injury.

- BRACE your body with the opposite arm, if possible.
- Reach for the instrument - bend your knees and waist, and keep your back straight.
- GRASP the instrument firmly with both hands
- LIFT with your legs.
- KEEP your shoulders level.

### Power Requirements

The line voltage requirements for the HP 70843 error performance analyzer and HP 70004A display are as follows:

**115 V line operation:** 90 to 135 V ac, 47 to 66 Hz

**230 V line operation:** 180 to 264 V ac, 47 to 66 Hz

The maximum power consumption is as follows:

**HP 70843:** 850 VA typical

**HP 70004A:** 350 VA typical

**Installation  
Preparation for Use**

---

**WARNING**

**This is a Safety Class 1 instrument (provided with a protective earthing ground, incorporated in the powercord). The mains plug shall only be inserted in a socket outlet provided with a protective earth contact. Any interruption of the protective conductor inside or outside of the instrument is likely to make the instrument dangerous. Intentional interruption is prohibited.**

---

**Noise Declaration**

LpA<70db

am Arbeitsplatz (operator position)

normaler Betrieb (normal position)

nach DIN 45635 pt.19 (per ISO 7779)

**Power Cables**

The display and error performance analyzer are each equipped with a three-wire power cable. When connected to a properly grounded power outlet, this cable grounds the instrument case. The power cable shipped with each instrument depends on the country of destination. The plug configuration and the power cable part numbers are listed below. If the appropriate power cable(s) are not supplied with your system or are damaged, notify the nearest Hewlett-Packard sales and service office and replacement(s) will be provided.

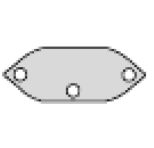
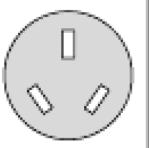
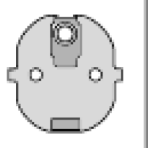
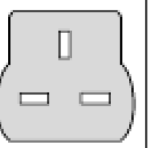
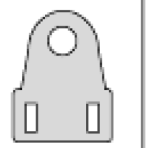
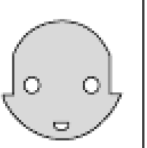
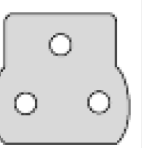
						
8120-2104	8120-1369	8120-1689	8120-1351	8120-1378 US 8120-4753 JAP	8120-2956	8120-4211

The color code used in each power cable is given below:

**Line:** Brown

**Neutral:** Blue

**Ground:** Green/yellow

---

**CAUTION**

Always use the three-prong ac power cord supplied with this instrument. Failure to ensure adequate earth grounding by not using this cord may cause instrument damage.

---

## Line Voltage Selection

### Instrument (HP 70843) Line Voltage Selector

There is no Line Voltage Selector switch on the HP 70843. The instrument line input circuits are auto-ranging and will operate at any voltage within the specified voltage range (90 to 135 and 180 to 264 volts). The Line Input module (on the rear panel) incorporates an ON/OFF switch - the '0' position is the OFF position. Refer to the paragraph on Line Fuses on page 2-9 for advice on replacing fuses.

---

**NOTE** See page 2-9 for fuse ratings for 115 V ac and 230 V ac operation.

---

---

**WARNING** **If this instrument is to be energized via an external autotransformer for voltage reduction, make sure that its common terminal is connected to a neutral (earthed pole) of the power supply.**

---

---

**CAUTION** This instrument has an autoranging line voltage input, be sure the supply voltage is within the specified range.

---

### Display (HP 70004A) Line Voltage Selector

---

**CAUTION** Before you connect the power cable to the display, check that the LINE VOLTAGE SELECTOR switch is set for the correct line voltage source.

If the wrong voltage is selected, one of the following may happen:

If 115 V line operation is selected and you connect to a 230 V ac line power source, the fuse may blow.

If 230 V line operation is selected and you connect to a 115 V ac line power source, the instrument will not power-on correctly.

---

**Installation  
Preparation for Use**

The LINE VOLTAGE SELECTOR slide switch is located through a slot in the left side-panel.

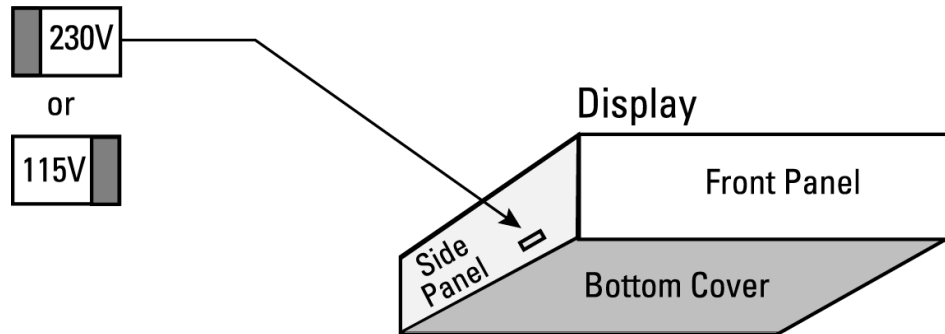

**Mainframe (HP 70001A) Line Voltage Selector (HP 71612 options UHF/UKB and UHG/UKB only)**

**CAUTION**

Before you connect the power cable to the mainframe, check that the LINE VOLTAGE SELECTOR switch is set for the correct line voltage source.

If the wrong voltage is selected, one of the following may happen:

If 115 V line operation is selected and you connect to a 230 V ac line power source, the fuse may blow.

If 230 V line operation is selected and you connect to a 115 V ac line power source, the instrument will not power-on correctly.

The LINE VOLTAGE SELECTOR slide switch is located through a slot in the bottom panel (the switch is set for 115 V operation in the diagram below).

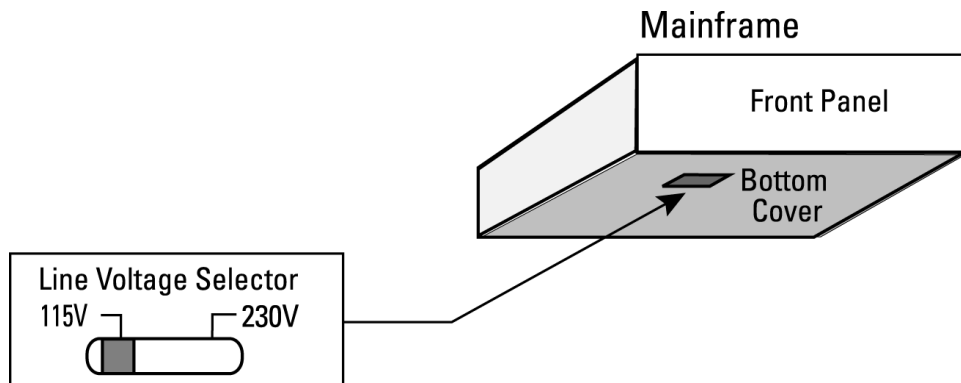

## Installation Preparation for Use

### Line Fuses

The line fuses of the instrument, display and mainframe are located in the line-module housings on the rear panel.

#### Accessing the HP 70843 Line Fuse

1. Ensure no power cable is connected to the line-module housing.
2. Use a screwdriver to lever open the fuse holder. There are two fuses in the fuse holder (one for 115V operation and one for 230V operation).

#### Accessing the Display (HP 70004A) and Mainframe (HP 70001A) Fuses

The display and mainframe use similar line-module housings. To access the fuses:

1. Ensure no power cable is connected to the line-module housing.
2. Use a screwdriver to lever open the fuse holder. A spare line fuse is located inside the fuse holder.

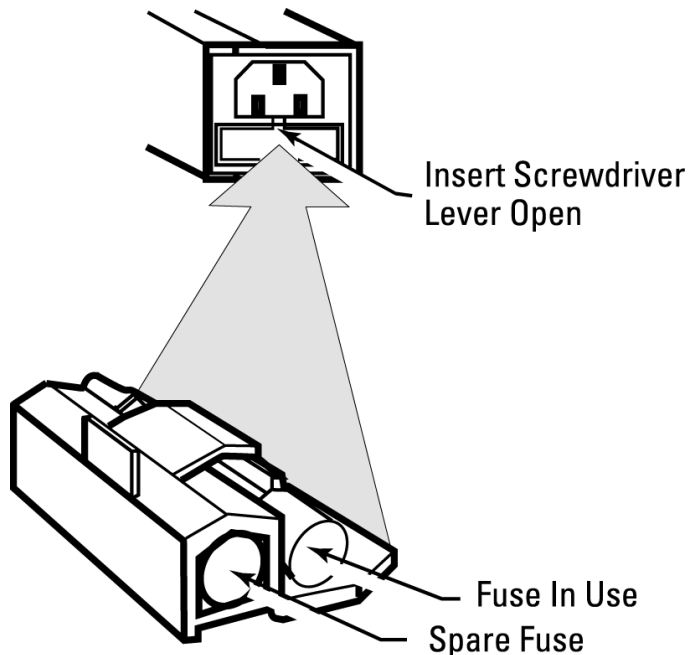

### Fuse Ratings

The fuse ratings and the part numbers for 115 V ac and 230 V ac operation are listed below:

- HP 70843: 115 V operation - F 12 A, 250 V, part number 2110-0051
- HP 70843: 230 V operation - M 7 A, 250 V, part number 2110-0326
- The Display and Mainframe fuse ratings are 6.3 A, 250 V (HP 2110-0703) for both 115 and 230 V ac operation.

**Installation  
Preparation for Use**

## HP-MSIB Address Switches

The HP-MSIB address of an HP 70843 error performance analyzer is factory preset to row 0, column 18. Both error detector and pattern generator share the same HP-MSIB address.

If you wish to change the HP-MSIB address, ensure you are fully aware of the HP-MSIB address protocol.

### Factory Preset HP-MSIB Addresses

The factory preset HP-MSIB addresses (row, column) are listed below:

HP 70004A display:	0, 20
HP 70843 error performance analyzer:	0, 18*
HP 70340A clock source:	1, 19
HP 70341A low frequency clock source:	2, 19

\* The column value defines the factory-preset HP-IB address.

### HP 70843 Address Switches

These are accessed via the instrument rear panel. The factory preset settings are shown in the following diagram:

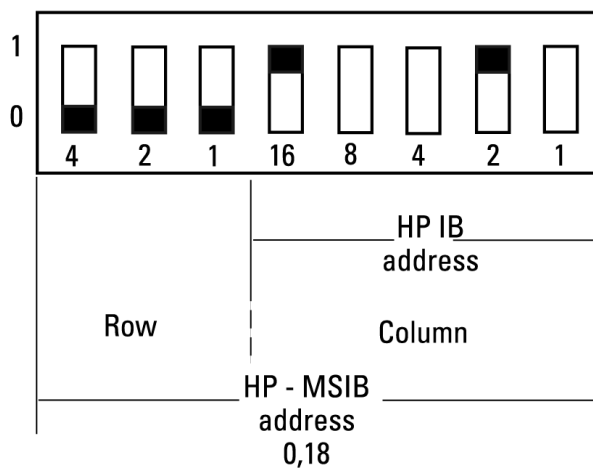

**Installation  
Preparation for Use**

**HP 70340A Clock Source Module Address Switches**

These switches are located on the clock source rear panel. The factory preset switch settings are row 1, column 19 as shown in the following diagram:

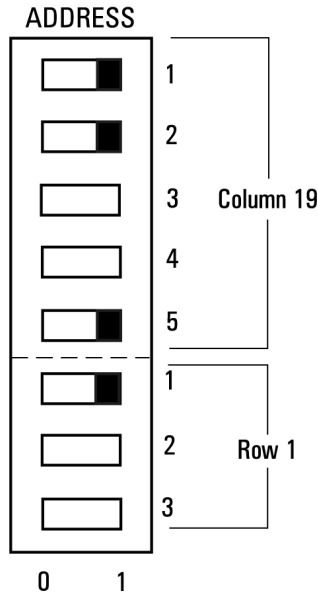

**HP 70341A Clock Source Module Address Switches**

These switches are located on the clock source rear panel. The factory preset switch settings are row 2, column 19 as shown in the following diagram:

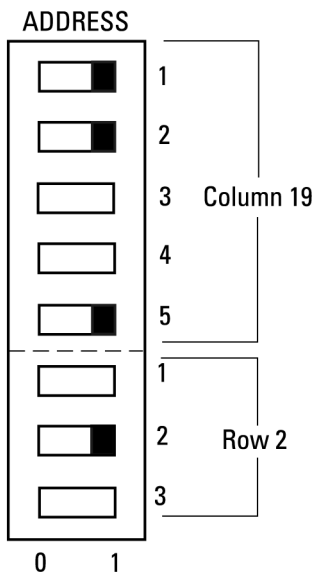

## Installation Preparation for Use

### HP 70004A Display Address Switches

These are located on the rear panel of the HP 70004A display, it has no row switches (it defaults to row 0) - only column switches (the factory preset settings are shown in the following diagram):

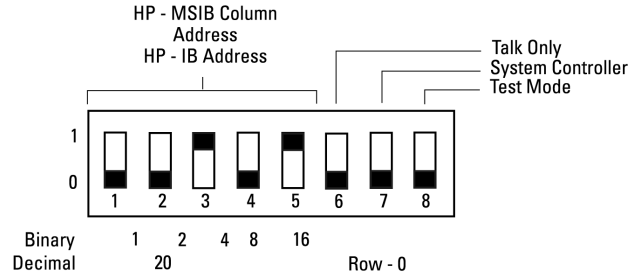

### HP-IB Address Switches

The HP-MSIB address switches also act as HP-IB switches. If you want your system to communicate over the HP-IB:

The row switches must be set to 0.

The column switches define the HP-IB address.

If you want to change the HP-IB address (for example, use an address that is different from that defined by the column switch settings), it is recommended that you use the Display, Address Map function keys as follows:

---

**CAUTION** It is not recommended that you change the HP-IB address using the HP-MSIB/HP-IB switches as these also change the HP-MSIB address. If the HP-MSIB address protocol is violated your system will fail to operate.

---

### To Change the HP-IB Address

1. Press the Display **DISPLAY** fixed label key.
2. Press the **Address Map** left-menu softkey.
3. Rotate the large display knob clockwise until the green box rests on the **70843 Err Perf Anl.**
4. Press **HP-IB ADDRSET** , select an address using the numeric keypad then press **ENTER** .

### Factory Preset HP-IB Addresses

The error performance analyzer HP-IB address is factory preset to 18 (column part of HP-MSIB switch setting).



**Installation  
Preparation for Use**

**Bench Operation**

Plastic feet are included with Mainframes and stand-alone instruments to provide bench operation convenience. The plastic feet are self-aligning when systems are to be stacked.

**Rack Mount Installation**

Front handles must be removed when fitting the system rack mount options.

**HP 71612 option 1CM - rack mount kit (HP part number 15810A)**

**HP 71612 option 1CP - rack mount kit with handles (HP part number 15811A)**

**HP 70843 option 1CM - rack mount kit (HP part number 5062-3979)**

**HP 70843 option 1CP - rack mount kit with handles (HP part number 5062-4073)**

The rack mounts available are illustrated below. Angled brackets (HP 12679C) may be ordered to provide additional rear or side support for the rack mounted instruments.

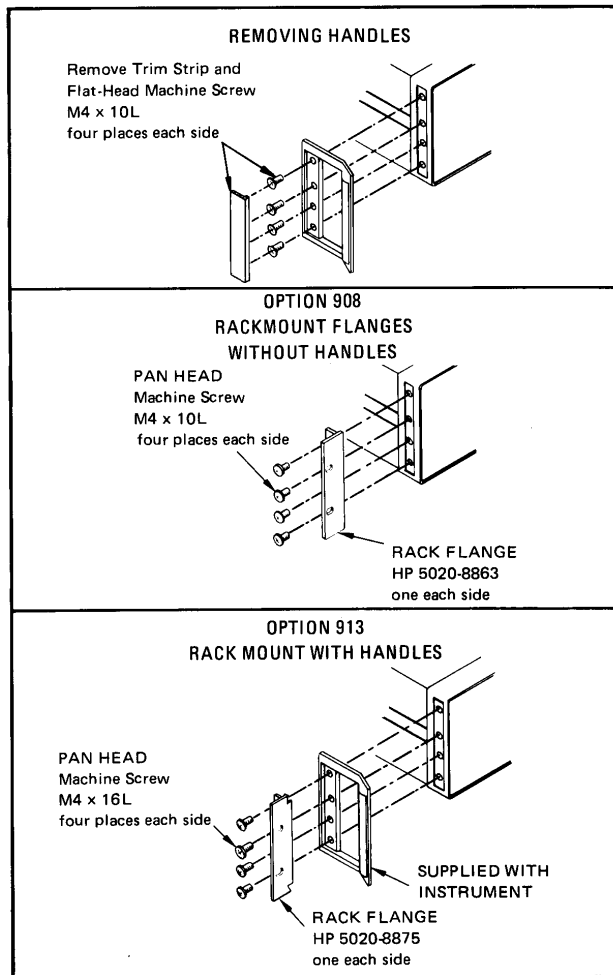

NOTE: LEFT FRONT IS SHOWN IN EACH EXAMPLE.

---

## System Installation

The following figure shows an error performance analyzer system.

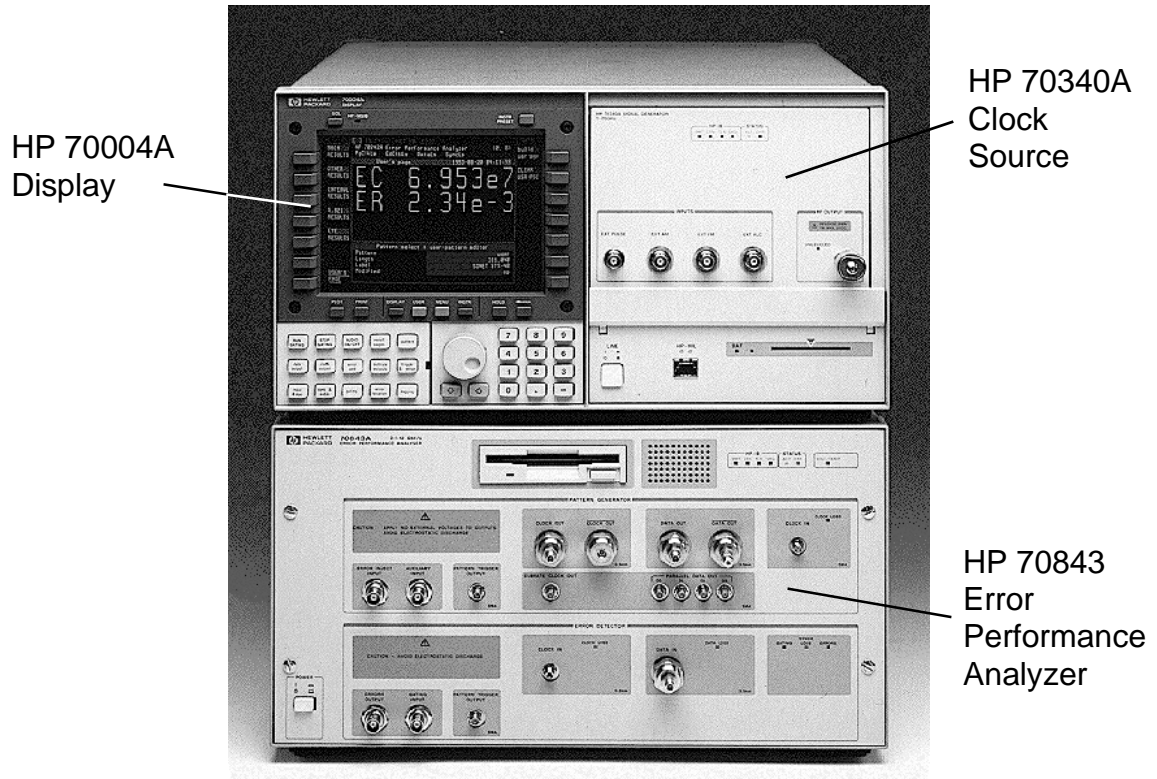

### Accessories

The following cables, connectors and terminations are supplied with your system.

#### Cables

4 off SMA cables, part number 8120-4948; use to connect the clock/data ports.

#### Connectors

5 off APC - 3.5 mm female to female, part number 5061-5311; use as savers for pattern generator clock/data outputs and error detector data input.

2 off APC - 3.5 mm male to female, part number 1250-2472; use as savers for error detector clock input and trigger output.

#### Terminations

7 off SMA terminations, part number 1250-2121; use on unused clock/data outputs.

**Installation**  
**System Installation**

**Procedure**

Use the following procedure to install your HP 71612 series system.

---

**CAUTION** Ensure that no power cables are connected. Also check that the LINE POWER switches are set to OFF.

---

---

**CAUTION** Ensure that the display line voltage selector switches are set for the line voltage being used, also check the fuse ratings, see pages 2-7 and 2-9. On HP 71612 option UKB instruments, check also the mainframe Line Voltage Selector and fuse.

---

1. Install the HP 70340A clock source module into the display.
2. Arrange the Display and HP 70843 for bench operation. The plastic feet on the Display and HP 70843 are self-aligning when systems are stacked. To rack mount your system, refer to **Rack Mount Installation**, see page 2-13.
3. Connect the HP-MSIB cables as follows:

---

**CAUTION** Your system must be powered down when connecting or disconnecting HP-MSIB cables.

---

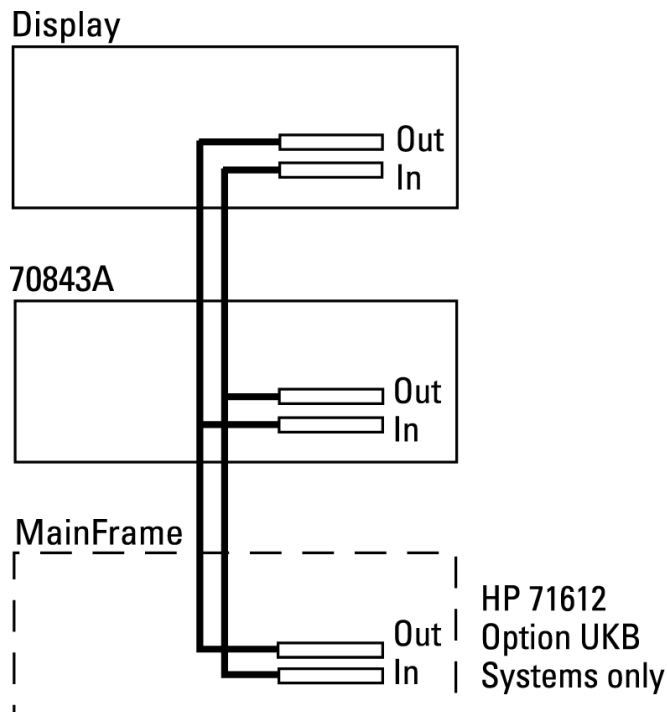

The diagram shows the systems viewed from the rear.

**Installation**  
**System Installation**

4. Connect the CLOCK IN port of the HP 70843 pattern generator to the CLOCK OUT of the clock source module.

---

**CAUTION** When tightening SMA connectors and terminations, ensure that the maximum torque setting used is 0.9 N-m.

---

---

**NOTE** The other front panel ports on the HP 70843 pattern generator and error detector are interconnected according to the application you want to undertake. All the necessary cables, adapters and 50 $\Omega$  terminations are provided with your instrument. Unused ports must be terminated in 50 $\Omega$ .

---

---

**CAUTION** Check the power cables you intend to use for damage before powering on your system, see the Power Cables on page 2-6.

---

5. Connect power cables to your system then connect the cables to the power outlets.

Your system is now ready for System Verification, see page 2-17.

---

## System Verification

This section contains procedures which will enable you to verify that your *error performance analyzer* has been correctly installed.

### Error Performance Analyzer System Verification

The HP 70843 error detector and pattern generator are connected back-to-back. then the system selftest and instrument preset parameters are used to verify correct installation. A description of what you will see during selftest is given in System Selftest at Power-on, see page 2-18 (since selftest takes only 15 seconds approximately to complete, you should read the description before powering on your system).

1. Interconnect the front panel ports as shown below, then prior to switching on your system, read Selftest at Power-on, see page 2-18.

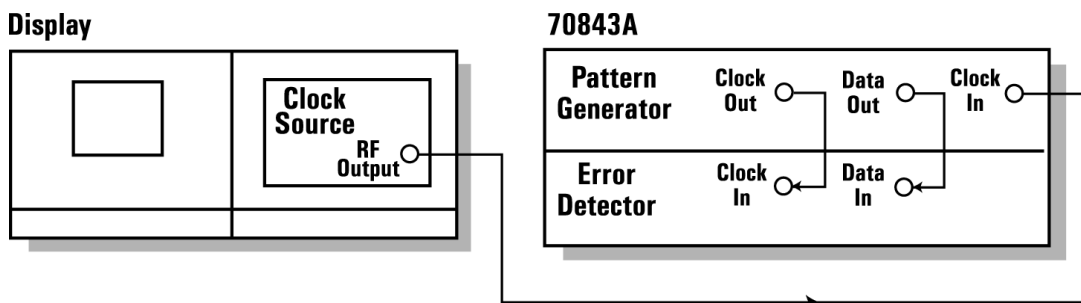

2. Switch on the two Line power switches (in any order) - wait approximately 15 seconds for selftest to end. Note that the HP 70843 line power switch is on the instrument rear panel.
3. Press the display **INST PRESET** key to set up the instrument preset parameters.
4. Check that the displayed clock frequency is 1.000 GHz and that the *ACT* indicator on the instrument is lit.
5. Press the display **DISPLAY** key, the *ACT* indicator should extinguish and an A should appear at the top left of the display.
6. Press the display **MENU** key, the A should disappear and the *ACT* indicators should light.
7. Press **input & eye** , **0/1 THR AUTO** , **CLK-DAT ALIGN** . Wait for the clock and data signals to align, then do a **0/1 THR CENTER** and wait for alignment to complete.
8. Press **RUN GATING** . The *GATING* indicator on the error detector and the *Gate* flag at the top right of the display should light.
9. Check that the displayed error count is 0.

If there are no errors, the system is ready for use.

## Selftest at Power-on

At power-on the error performance analyzer system performs a selftest (this takes approximately 15 seconds to complete). During this time the display, instrument, clock source and mainframe (option UKB instruments) operate as follows:

**Display:** The display is blank for the first few seconds of the selftest. It then shows a multi-colored raster. The raster sweeps to the right, to show a blue back-ground. For the remainder of the selftest the display is as follows:

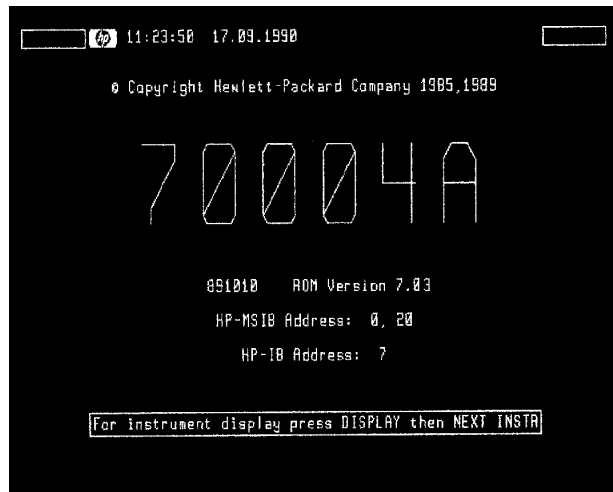

After selftest the display may continue to display the above, or will display the module parameters present prior to the last power down.

**HP 70843:** All front panel indicators are lit for approximately eight seconds then extinguished for the remainder of the selftest.

After selftest the **ACT** indicator should light.

**Clock Source Module:** All front panel indicators are lit for approximately five seconds then extinguished for the remainder of the selftest.

**Mainframe:** All front panel indicators extinguish except for **LINE**.

After selftest the **ACT** indicator should light.

## Installing/Removing Modules

This section describes how you install a clock source module into a Display and Mainframe.

### Installing an HP 70340A Clock Source Module into a Display

Use the following procedures to install your clock source into the display. To remove a module, perform the steps in the reverse order.

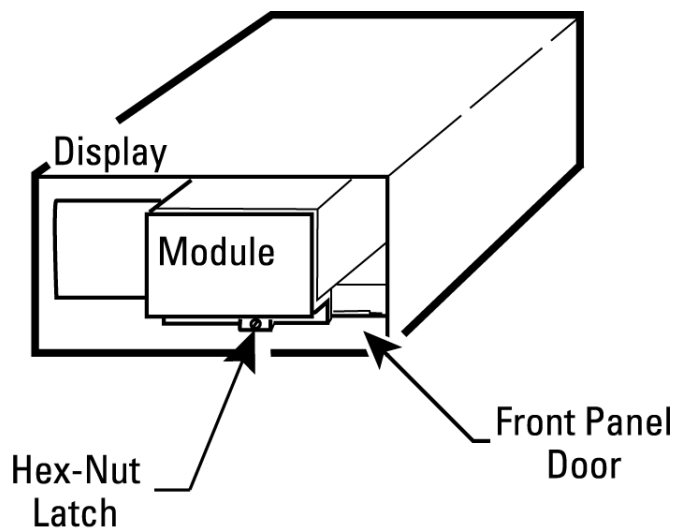

1. Set the display LINE power switch to off.
2. Open the front panel door then insert the module.
3. Secure the module by pressing against its front panel while tightening the hex-nut latch with an 8 mm hex-ball driver.

When removing a clock source module, disconnect any cables that may be connected to the rear panel.

## Installing an HP 70341A Clock Source Module into a Mainframe

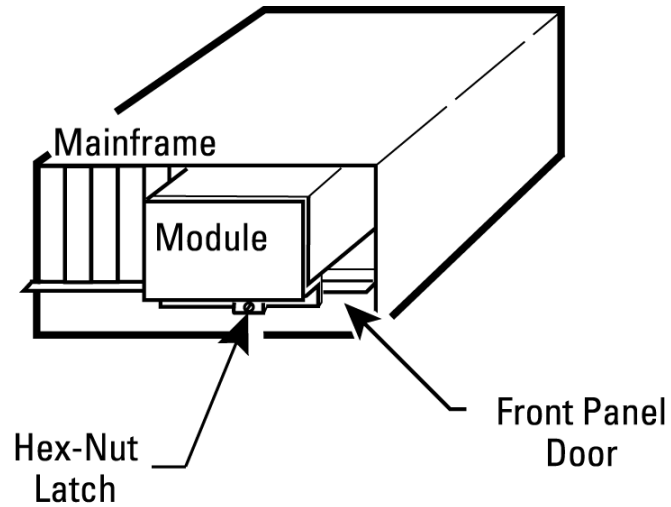

1. Open the front panel door, then insert the clock source module into the right side of the mainframe.

**CAUTION** The Mainframe LINE power switch must be set to off before the front panel door will open.

2. Secure the module by pressing against its front panel while tightening the hex-nut latch with an 8 mm hex-ball driver.

When removing a clock source module, disconnect any cables connected to the rear panel.



---

## **System Overview**

---

## Configurations

The HP 71612 Series of Gigabit testers can be configured into one of the following systems:

### System Options

- HP 71612 option UHF: 1-12 Gb/s error performance analyzer system
- HP 71612 option UHG: 1-12 Gb/s pattern generator system
- HP 71612 option UHH: 0.1-12 Gb/s error detector system

Each system comprises an HP 70004A display and an HP 70843 pattern generator or error detector or both. For HP 71612 option UKB systems, an HP 70001A mainframe and low frequency clock extension module is added.

An HP 71612 error performance analyzer system is shown in the following figure:

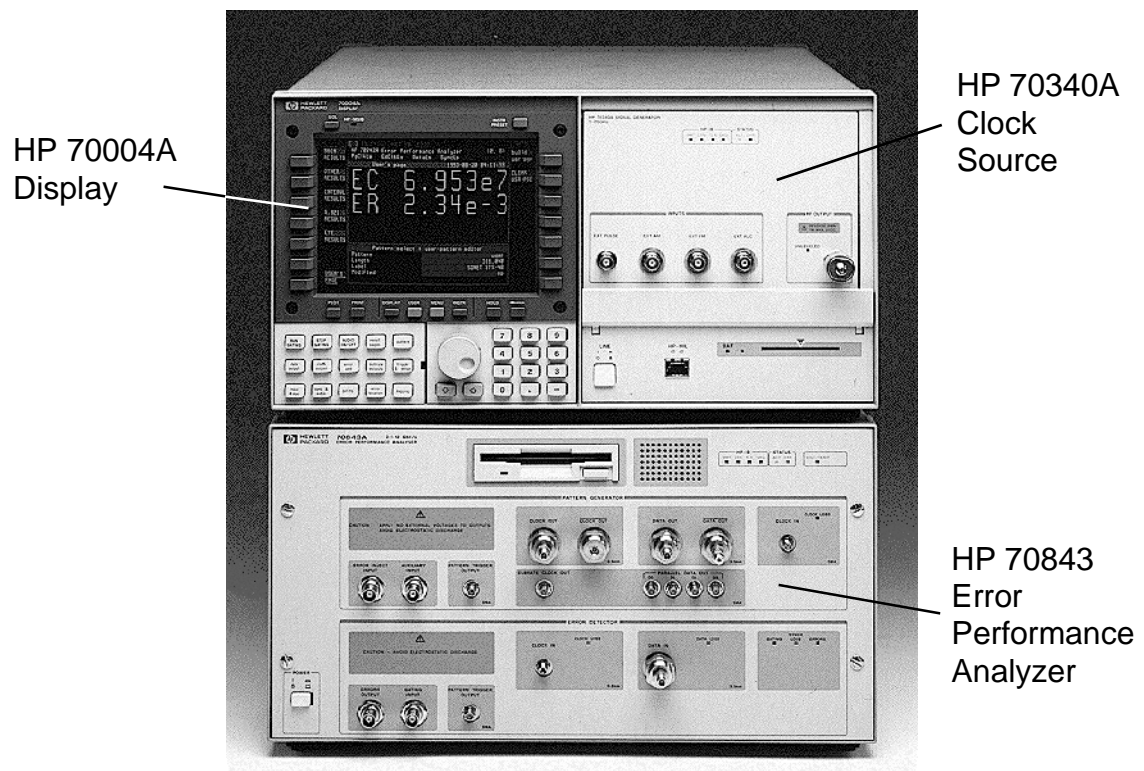

## System Overview Configurations

### Additional System Options

- HP 71612 option UHJ: error location analysis (cannot be ordered with option UHG pattern generator system)
- HP 71612 option UKB: low frequency clock extension of options UHF or UHG to 0.1 Gb/s.
- HP 71612 option UKC: delete clock source from option UHF or UHG

Refer to Chapter 1, *General Information*, for a complete list of HP 71612 options.

### HP 70843 Instrument Options

- HP 70843 option UHF: error performance analyzer (0.1 to 12 Gb/s)
- HP 70843 option UHG: pattern generator (0.1 to 12 Gb/s)
- HP 70843 option UHH: error detector (0.1 to 12 Gb/s)
- HP 70843 option UHJ: error location analysis (not available with option UHG)

### Documentation Overview

The manuals supplied with each system are listed in the following table:

Element	Product Number	Manual	HP Part Number	Comments
System	HP 71612	Operating/ Programming	71612-90011	This manual is supplied with all systems.
Display	HP 70004A	Operation Installation/ Verification	70004-90031 70004-90005	These manuals are supplied with all systems.
Mainframe	HP 70001A	Installation/ Verification	70021-90021	This manual is only supplied with HP 71612 option UKB (low frequency extension) systems.
*Clock source	HP 70340A	User's Guide	70340-90001	This manual is supplied with all systems.
Instrument	HP 70843	Operating/ Programming	71612-90011	This manual is supplied with all instruments.

\*Clock source documentation is not supplied if option UKC is ordered with your system. The clock source is only supplied with HP 71612 options UHF or UHG. It is not supplied with an HP 71612 option UHH, nor with any HP 70843 option.



---

**Operating Features and  
Specifications**

## **Introduction**

This chapter lists and describes the features and specifications of an HP 70843 error performance analyzer. Refer to Chapter 1 *General Information* for advice on instrument options and accessories.

## **Warm-up**

All specifications valid after a 30-minute warm-up period.

## **Operating Temperature Specification**

**Temperature range for specified operation:** 5 to 35°C; 100 MHz to 10 GHz, 5 to 40°C.

## **Calibration Interval**

Recommended 2 years

## Pattern Generator

### External connections

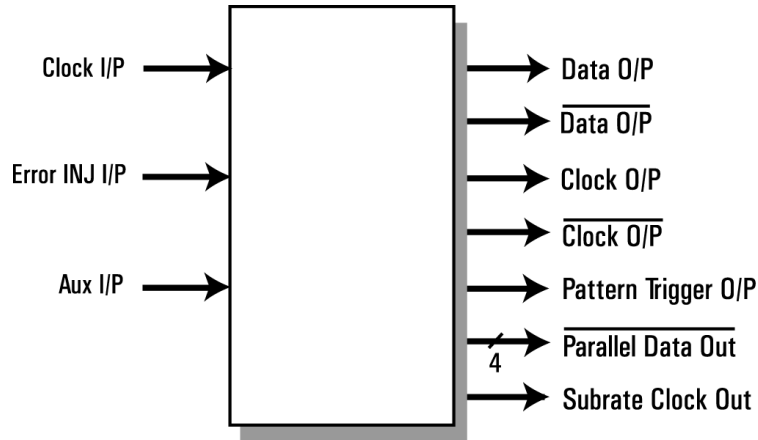

---

## Patterns

### PRBS Test Patterns

$2^{31}-1$  - polynomial  $D_{31} + D_{28} + 1 = 0$ , inverted

$2^{23}-1$  - polynomial  $D_{23} + D_{18} + 1 = 0$ , inverted (as in CCITT Rec O.151)

$2^{15}-1$  - polynomial  $D_{15} + D_{14} + 1 = 0$ , inverted (as in CCITT Rec O.151)

$2^{10}-1$  - polynomial  $D_{10} + D_7 + 1 = 0$ , inverted

$2^7-1$  - polynomial  $D_7 + D_6 + 1 = 0$ , inverted

### Zero Substitution/Variable Mark Density

#### Test Patterns

8192 bits, based on  $2^{13}-1$  PRBS

2048 bits, based on  $2^{11}-1$  PRBS

1024 bits, based on  $2^{10}-1$  PRBS

128 bits, based on  $2^7-1$  PRBS

## Operating Features and Specifications Patterns

### Zero Substitution

Zeros can be substituted for data to extend the longest run of zeros in the above patterns. The longest run can be extended to the pattern length -1. The bit following the substituted zeros is set to 1.

### Variable Mark Density

The ratio of 1s to total bits in the above patterns can be set to 1/8, 1/4, 1/2, 3/4, or 7/8.

### User-programmable test patterns

Variable length user patterns from 1 bit to 8M bits. Refer to Chapter 8 *User Patterns and Disk Operation* and Appendix B, page B-3, for detailed information on user patterns.

Table 4-1

Pattern Granularity

Pattern Length	Alternate Pattern Length	Resolution
>4 Mbit	>2 Mbit	256
>2 Mbit	>1 Mbit	128
>1 Mbit	>512 kbit	64
>512 kbit	>256 kbit	32
>256 kbit	>128 kbit	16
>128 kbit	>64 kbit	8
>64 kbit	>32 kbit	4
>32 kbit	>16 kbit	2
≤32 kbit	≤16 kbit	1

### Alternate test pattern - pattern generator only

Switch between two equal length user programmable patterns, each up to 4,194,304 bits, under the control of a front panel key, HP-IB or the auxiliary input port; changeover is synchronous with the end of a word. The length of the alternating patterns should be a multiple of 256 bits.

Two methods of controlling pattern changeover are available, oneshot and alternate. Refer to the paragraph on the *Auxiliary Input* (on page 4-10) for further information.

---

**NOTE**

The error detector is not affected by the pattern switching and is set to pattern A when Alternate Pattern is selected.

---



## Internal Disk Drive

The HP 70843 internal disk drive is used to store user data patterns. The disk supports MSDOS format 1.44 Mbyte 3.5 in. disks only. The disk functions supported are:

- Pattern read
- Pattern write
- Disk format
- Pattern delete

Refer to Chapter 8 *User Patterns and Disk Operation* for more detailed information on disk operation.

---

## Clock Input

Input for the clock to the pattern generator

### Features

- Set frequency - when used with HP 70340/70341 clock source
- Set frequency step - when used with HP 70340/70341 clock source
- Measure frequency
- Set output level of clock source

### Specifications

**Frequency range:** 100 MHz to 12 GHz

**Interface:** 0.45 V to 0.90 V pp ( $\leq 10$  GHz),  
0.63 V to 0.9 V pp ( $> 10$  GHz) dc coupled

**Impedance:** 50 $\Omega$  nominal

**Connector:** SMA female connector

**Amplitude:** 450 to 900 mV pp

**Note:** Do not apply dc volts.

## Data and Data (inverted) Outputs

The following pattern generator data output features are accessed using the **data output** key and its menu of softkeys.

### Features

- Polarity - normal or inverted data.
- Data high level adjust.
- Data amplitude adjust.
- External termination voltage 0/−2V or ac coupled.
- External attenuator set 0 to 40 dB for 0V termination.
- Delay v clock adjust.
- Output ON/OFF selection.
- Vertical data-eye cross-over adjust.
- Independent control of high level, amplitude and ON/OFF for DATA and  $\overline{\text{DATA}}$ .

### Data output features not controlled by data output softkeys

- Output gating - controlled by AUXILIARY INPUT port (see Auxiliary Input description on page 4-10).
- Error add - (see Error Add paragraph on page 4-8).

### Specifications

#### Data outputs - main

**Interface:** complementary dc coupled, reverse terminated.

**Impedance:** 50 $\Omega$  nominal.

**Format:** NRZ, normal or inverted.

**Amplitude:** 0.5 to 2 V pp in 10 mV steps.

**Transition times: (10% to 90%)** < 30 ps (typical at 2 V pp).

**Jitter:** typically less than 20 ps pp; <15 ps pp at 10 Gb/s

**Offset (range):** +1.5 V to −3.0 V in 10 mV steps.

**Clock/data delay:**  $\pm 1$  ns in 1 ps steps (100 MHz to 500 MHz),  
1 clock period (500 MHz to 12 GHz).

**Resolution:**  $\pm 1$  ps.

**Connector:** APC-3.5 male connector.

**Terminations:** 50 $\Omega$  −2V; 50 $\Omega$  ac coupled

**Operating Features and Specifications**  
**Data and Data (inverted) Outputs**

The following figures illustrate data/clock amplitude and high-level relationship for 0V and -2V terminations.

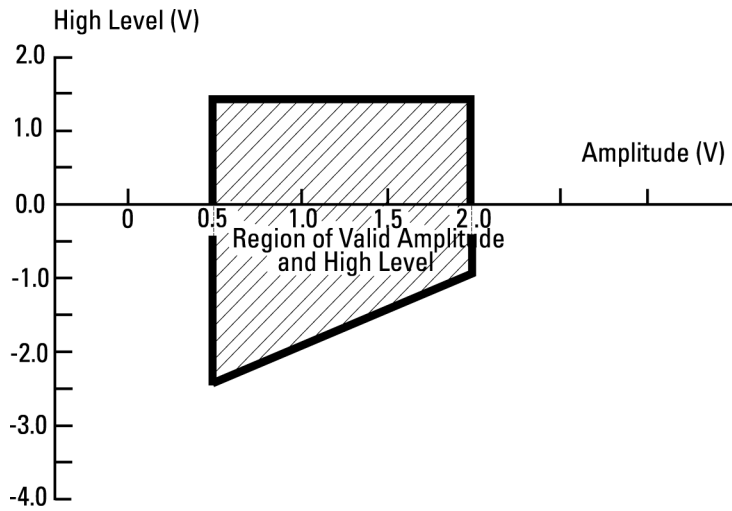

**Figure 4-1** Clock/Data Amplitude and High-Level Relationship with 0V Termination

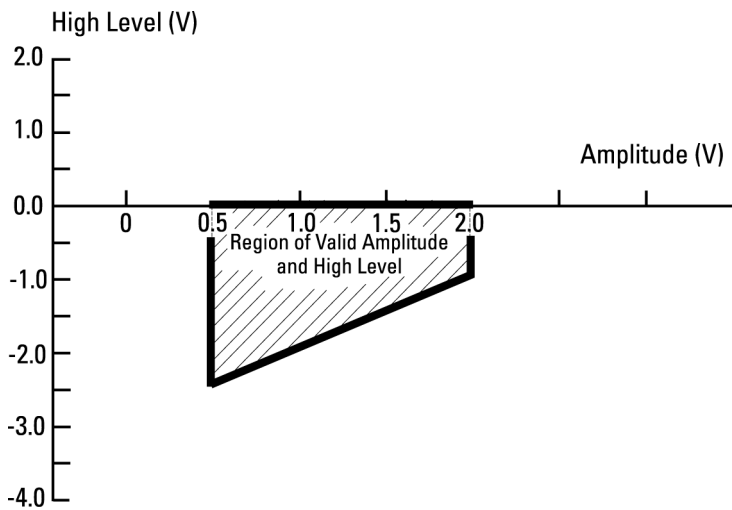

**Figure 4-2** Clock/Data Amplitude and High-Level Relationship with -2V Termination

## Operating Features and Specifications

### Clock and Clock (inverted) Outputs

#### Error Add

Add errors to the data using the **error add** key and its menu of softkeys. There are three modes of operation:

**Single:** Adds single errors on demand.

**Fixed:** Fixed error ratios of 1 error in  $10^n$  bits,  $n = 3, 4, 5, 6, 7, 8, 9$ .

**External:** Injects a single error in the transmitted test pattern on each rising edge at the ERROR INJECT INPUT port.

---

#### Clock and Clock (inverted) Outputs

The following clock output features can be set using the **clock output** key and its menu of softkeys.

- Clock high level adjust.
- Clock amplitude adjust.
- External termination voltage 0/−2V or ac coupled.
- External attenuator set 0 to 40 dB (0V termination only).
- Independent control of high level and amplitude for CLOCK and  $\overline{\text{CLOCK}}$ .

#### Specifications

##### Clock outputs - main

See figures 4-1 and 4-2 for amplitude and high-level specifications with 0V and −2V termination.

**Frequency range:** 100 MHz to 12 GHz.

**Interface:** Complementary, dc coupled, 50Ω, reverse terminated.

**Amplitude:** 0.3 to 2 V pp in 10 mV steps.

**Range:** +1.5 to −3.0 V in 10 mV steps.

**Connector:** APC-3.5 mm male connector.

## Subrate Clock & Data (inverted) Outputs

Four subrate  $\overline{\text{Data}}$  outputs (parallel data out ports) and one subrate Clock output are available. Subrate Data and Clock are at 1/4 the main Data and Clock rate. Subrate data is inverted relative to the main data output. When the main data is a pure PRBS, the subrate data is a PRBS at 1/4 the main data rate (every 4th bit is output). When a RAM based pattern (including mark density and zerosub patterns) is selected the data pattern output from each subrate port depends on the pattern length and will change if the trigger bit position changes. Refer to Appendix B for additional information.

The following subrate features are provided:

### Features

- Data high-level adjust.
- Data amplitude adjust.
- Clock high-level adjust.
- Clock amplitude adjust.
- Set Clock and Data to ECL.
- Set external termination voltage 0/-2V or ac coupled.

### Specifications

**Frequency range:** 1/4 of main clock rate.

**Interface:** dc coupled, 50 $\Omega$ , reverse terminated.

**Amplitude:** 0.5 V to 1 V pp in 10 mV steps.

**Range:** 0 to -1.5 V in 10 mV steps.

**Connector:** SMA female connector.

---

## Trigger Output

Provides an electrical trigger synchronous with the pattern for use with an oscilloscope or other test equipment. It operates in two modes, pattern and divided clock. Refer to pages 7-16 and 7-17 for more information on Trigger Outputs.

### Features

- Pattern or clock trigger
- Pattern trigger position set

## Operating Features and Specifications

### Auxiliary Input

#### Pattern Mode

In pattern mode the trigger is synchronized to repetitions of the output pattern.

#### PRBS $2^{31}-1$ , $2^{23}-1$ , $2^{15}-1$ , $2^{10}-1$ , $2^7-1$

Pulse synchronized with a specified bit in the pattern. The repetition rate is 1 pulse for every 32 pattern repetitions.

#### Alternate pattern

Pulse at bit 0 of the pattern or trigger output alternates with pattern.

#### All other patterns

Pulse synchronized to any bit of the pattern. The repetition rate is a function of the pattern length. The rate is the lowest common multiple of 256 and the length example:

- Pattern length = 32767 => 1 pulse/256 pattern repetitions
- Pattern length = 32768 => 1 pulse/pattern repetition

#### Divided Clock Mode

In divided clock mode the trigger is a square wave at the clock rate divided by 32 or 8.

---

**NOTE**

Clock divided by 8 trigger has lower jitter. Clock divided by 32 has same timing relative to data as the pattern trigger.

---

#### Interface

**Pulse width:** 32 bits

**Pulse amplitude:** Output terminated 50Ω to 0V; High: 0V nominal; Low: -0.4 V nominal

**Impedance:** 50Ω nominal

**Interface:** dc coupled

**Connector:** SMA female connector

---

### Auxiliary Input

The AUXILIARY INPUT port can be used to control user programmable alternate test patterns or inhibit data output (force the data to a fixed low level).

---

## Operating Features and Specifications

### Auxiliary Input

#### Alternate Pattern Selected

The instrument will output one of two patterns (A or B) at the end of either pattern. The auxiliary input controls which pattern is output in one of two modes:

- Oneshot - a rising edge on the auxiliary input inserts a single version of B pattern into repetitions of pattern A.
- Alternate - The logic state of the signal at the auxiliary input determines which pattern is output. A logic '0' will output pattern A.

---

**NOTE** In both cases, switching between patterns is at the end of a pattern and is hitless (error free).

---

#### Data Output Inhibit (Gating mode)

If an Alternate Pattern is not selected, an active (TTL low) signal at the auxiliary input port forces (gates) the data to a logic zero at the next 32-bit boundary in the pattern. See the following figure:

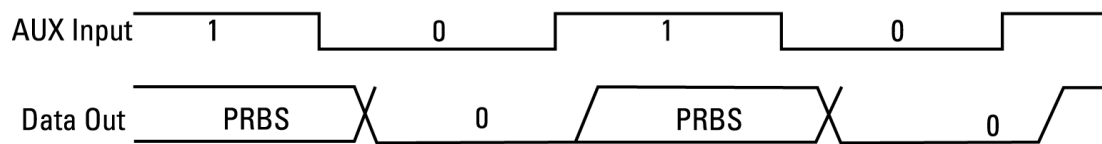

---

**NOTE** Connecting an external termination to the auxiliary input will pull it low and disable the data output.

---

#### Interface

**Interface:** dc coupled

**Levels:** TTL levels (active low)

**Connector:** BNC female connector

#### To Select Oneshot Mode

Select **pattern** then set **ALTPAT AUX USR** to **AUX** and **ALTPAT ALTONCE** to **ONCE** .

#### To Select Alternating Mode

Select **pattern** then set **ALTPAT AUX USR** to **AUX** and **ALTPAT ALTONCE** to **ALT** .

## Error Inject Input

The external ERROR INJECT INPUT adds a single error to the data output for each rising edge at the input.

### Interface

**Levels:** TTL compatible (active low)

**Connector:** BNC female connector

**Minimum pulse width:** 100 ns

---

## Status Indicators

### Pattern Generator indicators

- Clock Loss: Indicates nominal low clock power at clock input port.

### Error Detector indicators

- Clock Loss: Indicates nominal low clock power at clock input port.
- Data Loss: Indicates no data transitions in the last decisecond.
- Sync Loss: Error detector out of pattern sync (see sync gain/loss criteria spec).
- Gating: Measurement in progress.
- Errors: Indicates one or more data errors in the last decisecond.

### General instrument indicators

- HP-IB RMT, TLK, LSN, SRQ: standard indicators
  - MSIB ACT, ERR: standard indicators
  - VOLT/TEMP: instrument has detected over-temperature or abnormal voltage condition and has shut down. Power cycle required to recover.
- 

## Rear Panel Switches

- 8-way DIL switch for HP-IB/MSIB address.
  - Line input module on/off switch.
-



## Error Detector

### External connections

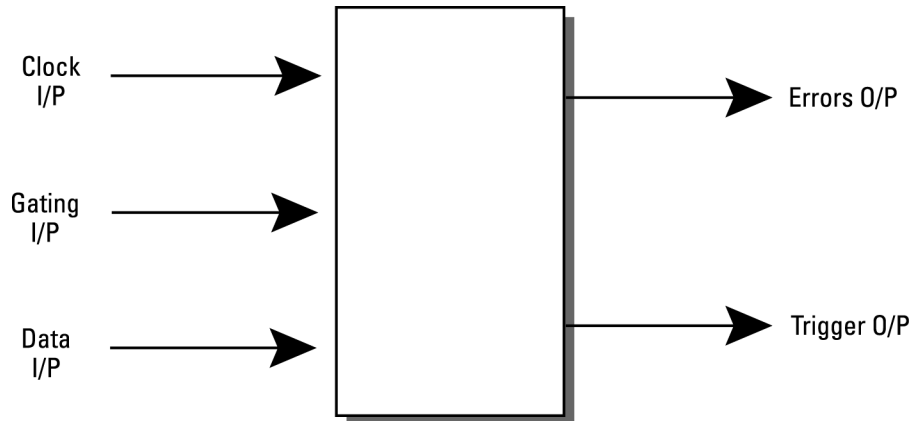

---

### Clock Input (error detector)

#### Features

- Switchable termination voltage 0V or -2V.
- Input frequency measurement.

#### Specifications

**Frequency Range:** 100 MHz to 12 GHz.

**Amplitude:** 450 to 900 mV pp.

**Range:** +1.5V to -4V.

**Interface:** dc coupled.

**Impedance:** 50Ω

**Input termination:** switchable 0V or -2V.

**Sensitivity:** <100 mV pp (typical at 10 Gb/s).

**Connector:** APC-3.5 mm female connector.

## Data Input

The error detector data input port offers the following features, selectable using the **input & eye** key and its menu of softkeys.

### Features

- Data polarity - normal or inverted data.
- Auto or manual slicing.
- Set manual slicing level.
- Termination voltage - 0/-2V.
- Measure auto slicing voltage.
- Clock/Data delay adjust.
- Clock/Data alignment.
- 0/1 threshold centre.

### Specifications

**Impedance:** 50Ω to 0V or -2V, dc coupled.

**Format:** NRZ.

**Amplitude:** 0.5 to 1 V pp.

**Sensitivity:** <50 mV pp (typical for 2<sup>23</sup>-1 PRBS input at 10 Gb/s 0V high level).

**Decision threshold range:** +1V to -3V in 1 mV steps.

**Range:** +1.5V to -4V.

**Data input range:** +1.5V to -4V.

**Clock/Data phase alignment:** ±1 ns in 1 ps steps (100 MHz to 3 GHz)  
1 clock period (3 to 12 GHz) in 1 ps steps.

**Connector:** APC-3.5 mm male connector.

---

## Pattern Trigger Output (error detector)

Provide an electrical trigger synchronous with the error detector reference pattern.

### Features

- Pattern or clock trigger.

## Operating Features and Specifications

### Errors Output

#### Pattern Mode

In pattern mode the pulse is synchronized to repetitions of the output pattern.

#### PRBS $2^{31}-1$ , $2^{23}-1$ , $2^{15}-1$ , $2^{10}-1$ , $2^7-1$

Pulse synchronized to repetitions of the pattern. The repetition rate is 1 pulse/32 pattern repetitions.

#### All other patterns

Pulse synchronized to repetitions of the pattern. The repetition rate is a function of the pattern length. The pulse occurs at that lowest common multiple of 256 and the length example:

- Pattern length = 32767 => 1 pulse/256 pattern repetitions
- Pattern length = 32768 => 1 pulse/pattern repetition

#### Divided Clock Mode

In divided clock mode the trigger is a square wave at the clock rate/8.

#### Specifications

**Interface:** dc coupled.

**Impedance:** 50Ω nominal.

**Connector:** SMA female connector.

**Amplitude:** High: 0V nominal; Low: -0.4 V nominal.

---

#### Errors Output

Provides an electrical signal to indicate received errors. The output is the logical 'OR' of errors in a 32-bit segment of the data.

#### Features

- Pulse length switchable - RZ or stretched.

#### Interface

**Format:** RZ, active high.

## Operating Features and Specifications

### Gating Input

**Interface:** dc coupled.

**Impedance:** 50Ω nominal.

**Amplitude:** High: 0V nominal; Low: -0.4 V nominal.

**Pulse Width:** For 1-bit error: 16 clock periods nominal or stretched 200 ns.

**Connector:** BNC female connector.

---

## Gating Input

The Gating Input is used to enable the error counters including during burst gating mode. In both these cases the error counters will always be enabled for a multiple of 32 pattern bits. When the Error Detector's clock and data inputs are continuous the Gating Input alone provides sufficient control of the bit error counting functions. If, however, the data input is not continuous then this input should be used together with the **Burst Gating** mode described under *Gating Menu* on page 7-33.

The error counter control provided by the Gating Input is independent of the *Measurement Gating* configured via the **Error Detector gating control** configuration menu and controlled via **RUN GATING** and **STOP GATING**. Refer to **Measurements** on page 4-18 and **Measurement Period** on page 4-22.

## Interface

**Levels:** TTL levels (see note below).

**Pulse Width:** 10μs at 100 MHz; 1μs at 10 GHz.

**Connector:** BNC female connector.

---

### NOTE

Connecting an external termination to the gating input will pull it low and disable the instrument error counters. Gating resumes when the Gating Input returns high.

---

## Automatic Clock-to-Data Alignment

### Introduction

An important feature of the HP 70843 error detector is the ability to automatically align the clock and data inputs such that the error detector samples in the middle of the *eye* (in the time axis). This reduces setting-up time as it automatically compensates for delays in the clock/data paths, preventing unnecessary errors.

The delay point in the *eye* at which the error detector samples can also be set manually using the **DAT I/P DELAY** softkey (part of the **input & eye** menu of softkeys).

### Definition

In order for the system to align the clock with the data (at the error detector input) it must find the edges of the data input *eye*. The *eye* edge is defined as a data input delay point where the Bit Error Ratio (BER) measured over a decisecond interval is less than or equal to a pre-defined threshold, and another adjacent point which is greater than the threshold. The *Eye Edge Threshold* can be set by the user to any value between  $10^{-1}$  and  $10^{-7}$  either via the **EYE EDG THRSHLD** softkey or remotely.

It is recommended that you perform the Clock-to-Data alignment procedure each time you configure an HP 71612 Series error performance analyzer. Normally this would be after setting up instrument parameters such as Pattern, Data Output (Level, Polarity) and Data Input (0/1 threshold, polarity).

### Eye Width

Each time a successful clock-to-data alignment procedure is performed the eye width is calculated, and displayed on the EYE RESULTS page (select **result pages**), then **EYE RESULTS**. This result can be added to the USER'S PAGE.

---

#### NOTE

The clock/data alignment process time is pattern-dependent, and with some large user-patterns alignment can take several minutes. If you wish to select a user pattern, it is recommended that you first perform clock/data alignment on a pure PRBS. This does not affect alignment accuracy and can save you valuable time.

---

#### NOTE

Ensure that the received clock frequency is stable before performing a clock-to-data alignment procedure.

---

## Automatic 0/1 Threshold Center

The 0/1 threshold center operation is used to set the 0/1 threshold midway between two points, top and bottom of the *eye*, where the bit error ratio is equal to a selectable threshold. The *eye* height is calculated and displayed (on the EYE RESULTS page). The BER selectable threshold is set using the **EYE EDG THRSHLD** key.

The **0/1 THR CENTER** function can be used to determine the optimum sampling point for asymmetric *eyes*, or on patterns with an unequal mark-density.

### To perform a 0/1 Threshold Centering

Select **input & eye** then press **0/1 THR CENTER** .

## Data Input 0/1 Threshold

### Introduction

There are three methods of determining the 0/1 Threshold of input signals at the error detector data input; they are Manual, Automatic Track and Automatic Center.

If the signal at the error detector data input is a standard PRBS or a clean signal (no excessive noise or jitter) with a 1:1 mark density, use the Manual or Automatic Track Modes, otherwise use the Automatic Center mode.

**Manual:** 0/1 threshold can be set manually.  
**Range:** +1 to -3V nominal  
**Resolution:** 1 mV nominal

**Automatic Track:** Tracks the mean dc level of the input signal. The 0/1 threshold calculated is displayed.

**Automatic Center:** The error detector sets the 0/1 threshold midway between two points, the top and bottom of the eye, where the bit error ratio is equal to a selectable threshold. The eye height is calculated and displayed.

---

## Measurements

The error detector counts bit errors by comparing data bit-by-bit with the internally-generated reference pattern. All measurements run during the gating periods with the exception of Delta Error Count and Delta Error Ratio. These measurements run continuously to enable user adjustments for minimizing errors. The measurements are as follows, (refer to Appendix A for measurement definitions):

## Operating Features and Specifications Measurements

- Bit Count
- Error Count
- Delta Error Count
- Error ratio
- Delta Error Ratio
- 0 - >1 Error Count
- 0 - >1 Error Ratio
- 1 - >0 Error Count
- 1 - >0 Error Ratio
- Errored Intervals - intervals seconds, deciseconds, centiseconds, milliseconds
- Error-free Intervals - intervals seconds, deciseconds, centiseconds, milliseconds
- Sync Loss Seconds
- Power Loss Seconds
- G.821 Error Analysis

The Bit Count result is provided in particular for use whenever the detector's Gating Input is being used to enable the bit error counters both in Normal and Burst Gating modes. Whenever the Gating Input is switching the measurement period is not continuous and hence the number of measured bits will no longer be equal to the *Gating Elapsed* multiplied by the *Err Det Clock Freq*. The ratio:

$$\frac{\text{Bit Count}}{\text{Gating Elapsed} * \text{Err Det Clock Freq}}$$

allows the user to confirm the proportion of the measurement gating period for which the Gating Input enabled the clock and bit error counters.

### Error Analysis

The Error Analysis is based on CCITT Rec G.821 and is derived from the bit error results.

- % Unavailability
- % Availability
- % Errored Seconds
- % Severely Errored Seconds
- Degraded Minutes

### Power-loss Seconds

This is displayed as the number of seconds the error detector is not able to make measurements during a gating period due to ac power loss. The gating continues to the end of the selected period following a restoration of power.

## Sync-loss Seconds

Displays the number of seconds the error detector lost pattern synchronization during a gating period.

## Frequency Measurement

The incoming clock frequency is measured and displayed to five significant digits.

## Result Logging

Refer to Chapter 10 *Data Logging* for information on logging results.

---

## Error Location (HP 71612 or HP 70843 Option UHJ)

Error location is available only for RAM-based patterns. It has three forms:

- Bit BER
- Error location capture
- Block BER

### Bit BER

Bit BER measurements are measurements made on a specific bit in a RAM-based user defined pattern. The specific bit is the “BER location” and is specified by an address. This measurement aids in identifying systematic errors causing a specific bit to change value.

### Measurements

- Bit BER - BER of the BER location
- Bit error count - error count of the BER location
- Delta bit BER
- Delta bit error count

Bit BER and Bit error count are affected by gating like normal BER. Delta bit BER and delta bit error count run continuously like normal delta BER.

The BER location may be specified by the customer as an address. After the location is specified gating is restarted if the instrument was gating before the location was specified.

### Error location capture

Error location capture allows you to capture the actual position of errored bits in a user defined pattern.



**Operating Features and Specifications**  
**Error Location (HP 71612 or HP 70843 Option UHJ)**

To initiate a measurement select **error location** then **CAPTURE ERROR**. The instrument searches for the first bit errored bit in the pattern. The address of the errored bit will be displayed along with the bit pattern surrounding the highlighted errored bit (see below). The instrument performs Bit BER, Bit error count, and also Delta Bit BER, Delta bit count on the captured bit.

Select **result pages** then **OTHER RESULTS** to view the **BIT:** results.

After an error is located the instrument displays:

```

BIT: Error Address                                nnn
Data window      xxxx xxxx xxxx xxxx xxxx xxxx xxyy xxxx
  
```

- **xxx..** - pattern around error, 28 bits before error and 3 bits after error are displayed
- **y** - the reference value of the errored bit in inverse video

**Block BER**

Block BER measures the BER of a range of bits in the pattern. It replaces normal BER measurements. Ranges of bits must be a multiple of 32 bits with the block specified by a start location and block length. This measurement is essential when trying to locate the cause of systematic errors which can affect a section of bits, for example a corrupt header in a SONET or SDH frame.

Pattern sync is affected since normal BER is replaced by the block results.

In general bit or block BER is not measured on every repetition of the pattern. The number of repetitions depends on the pattern length.

**Table 4-2**

**Pattern Length/Number of Repetitions for Bit/Block BER**

<b>Pattern length</b>	<b>Number of repetitions</b>
Odd	256
Multiple of 2	128
Multiple of 4	64
Multiple of 8	32
Multiple of 16	16
Multiple of 32	8
Multiple of 64	4
Multiple of 128	2
Multiple of 256	1

## Measurement Period

The measurement period is configured from the menu accessed via **gating**

### Measurement Period Features

- **Length:** The length of the measurement period can be set as a time period, number of bits or number of errors.
- **Timed Measurement Period:** Can be set from 1 second to 99 days, 23 hours, 59 minutes 59 seconds in 1 second steps.
- **Number of Bits:** The time for the number of bits to be received to a resolution of 1 second. Can be set for 10n bits, n = 7 to 15.
- **Number of Errors:** Time for number of errors to be detected to a resolution of 1 second. Can be set for 10, 100 or 1000 errors.
- **Real-time Clock:** Provides time and date information for event logging. Battery back-up allows clock to continue running when the instrument is switched off or power fails.
- **Elapsed Time Indication:** Shows elapsed time from the start of a gating period; resets to zero at the start of each gating period; holds value when measurement stopped.

### Gating modes

There are three gating (measurement timing) modes: Manual, Timed Single and Timed Repeat.

**Manual:** Gating period is controlled by the **RUN GATING** and **STOP GATING** keys. Accumulating results are displayed throughout the measurement and the end of measurement results are held until a new gating period is started.

**Single:** Gating period is started by pressing the **RUN GATING** key and terminates at the end of the gating period set by the user. Accumulating results are displayed throughout the gating period and the end of gating results are held until a new gating period is started.

**Repeat:** Similar to Single but when one timed gating period ends, a new identical period starts. This continues until the measurement is terminated by pressing the **STOP GATING** key. The measurement results displayed during any period can be the final results of the previous period or the accumulating results for the current period. There is no “deadtime” between consecutive periods. The gating period excludes any periods when the instrument is not powered.

## **Gating Period Definition**

- Time - 1 second to 99 days, 23 hours, 59 minutes, 59 seconds.
- Errors - 10, 100 or 1000.
- Bits - 1E07 to 1E15 bits.

All gating periods to 0.1s resolution.

Refer to *Measurements* on page 4-18 for details of the effect of switching the detector's **Gating Input** during gated measurement periods.

## **Burst gating**

Burst gating is always used together with the error detector GATING INPUT and is available only with PRBS patterns  $2^{31}-1$ ,  $2^{23}-1$ ,  $2^{15}-1$ ,  $2^{10}-1$  and  $2^7-1$ .

Although the Gating Input enables the clock and bit error counters, where the data input is not continuous, the Gating Input is often not sufficient to allow the detector to be kept synchronized throughout a series of bursts of the selected pattern. The only exception to this is where the data input pattern resumes, at the time when the Gating Input becomes active, from the pattern bit which would have been received had the data been continuous. In this special case selecting manual Sync Mode, once pattern synchronization has been gained, prior to the first deactivation at the Gating Input will allow error free reception. In all other circumstances where the data input is not continuous, for example in the testing of optical fibre loops, the instrument's Burst Gating mode should be selected.

A further requirement of this mode of operation is that a clock is provided at the Error Detector's clock input **all** the time. Should it be necessary to use a clock recovered from the data input during the measurements, then an external switch should be deployed to switch between the recovered clock and a continuous clock (e.g. from the Pattern Generator). In this configuration the switch should select the recovered clock whenever it is available but the Gating Input should only go active after the recovered clock has established a stable amplitude and a fixed phase with respect to the burst of pattern data bits. Similarly the Gating Input should be deactivated prior to either the onset of any transients in the recovered clock or the end of the data burst.

While in burst gating mode the error detector:

- Attempts to synchronize to the incoming data on every low to high transition of the Gating Input.
- Following each synchronisation attempt the detector counts bits and errors while the Gating Input remains high.
- As is the normal function of the Gating Input, all measurement counters are disabled whenever the Gating Input is low.

## Operating Features and Specifications

### Pattern Synchronization

---

**NOTE**

The Synchronization threshold does not affect the error pattern synchronization attempt but will affect the instrument's "SyncLs" status.

While Burst Gating is selected the only available *Gating repeat mode* is manual untimed.

If the received data is errored during the synchronization attempt all measured error counts are invalid.

The received clock must be continuous when burst gating is enabled.

---

---

## Pattern Synchronization

### Synchronization Modes

Synchronization to the incoming pattern can be performed automatically or manually. In manual mode, the START SYNC softkey forces the error detector to attempt synchronization with the received pattern.

### Sync Gain Loss Criteria

The criteria for gaining or losing synchronization is the error ratio in a 1 ms interval. Selectable error-ratio thresholds of  $1E-1$  to  $1E-8$  are provided. Refer to Appendix B *Operating Notes* for advice on setting sync thresholds.

### Synchronization Times

- PRBS patterns - <0.2s
  - STM64 frame at 10 GHz - <2.8s
  - <10 kbit pattern, >1 GHz - <1s
- 

## Audible Output

The instrument has an audible output which varies with error rate. The effect of changing error rate is:

- Isolated errors - output produces a 100 ms tone.
  - Other error rates - 5% change in error rate produces an audible change.
-

## Operating Features and Specifications

### Logging to External Printer

The audible output may be switched off or set to one of 15 volume levels. An audible output can also sound when sync loss occurs; selectable with the **AUDIO SYNCLS** key on the **sync & audio** menu.

---

## Logging to External Printer

### Functions

- Log on demand.
- Logging on/off.
- Log on error, end of gating period, error rate>threshold, alarms.
- Set logging threshold.
- Select HP-IB controller capability.
- Select HP-IB printer (HP DeskJet supported).
- Squelch on/off.

Refer to Chapter 10 for a detailed description of the measurement and status logging functions and, where the logged output is to be directed to an external HP-IB controller, to the HP 71612 Programming Manual (at the rear of this manual).

---

## To Set Up Your Own Display of Results or Status Information

The HP 71612 Series System gives you the opportunity to display on the screen a page containing results or status information important to you. This is called the *User's Page* and is setup as follows:

The following procedure shows you how to display and view the current *User's Page* selections, and edit (or build) the page to show your own choice of results or status information.

The process of editing the *User's Page* is referred to as *Building the User's Page*, and this is accomplished using the **build usr-pge** softkey.

### Procedure

#### Select and View the User's Page

1. Press the **result pages** hardkey, then the **USER'S PAGE** softkey.

**Operating Features and Specifications**  
**To Set Up Your Own Display of Results or Status Information**

The *User's Page* is now displayed and shows the results or status information selected by the previous user.

**To Build Your Own User's Page**

1. Select result pages, **USER'S PAGE**, **build usr-pge**.

You can now select from the choices offered in the **build usr-pge** menu of softkeys and build up the display to show the status or results information you wish. As you select a softkey the display will change to reflect your choice; the softkey selected is underlined. Refer to *Build User Page Menu Map* on page 6-16 for a chart of the selections offered.

---

## **Getting Started**

---

## Introduction

The purpose of this chapter is to instruct first time users how to quickly become proficient at operating the HP 71612 Series error performance analyzer.

### Using the HP 70004A Display

The HP 70004A display serves as the *front panel* for instruments in the HP 71612 Series Systems, and as your window for viewing current system configuration and measurement results. The HP 70004A display has 14 **softkeys** (7 on each side of the screen), **FIXED LABEL** keys above and below the screen, and 15 instrument hardkeys. All instrument functions/parameters are set up using these keys.

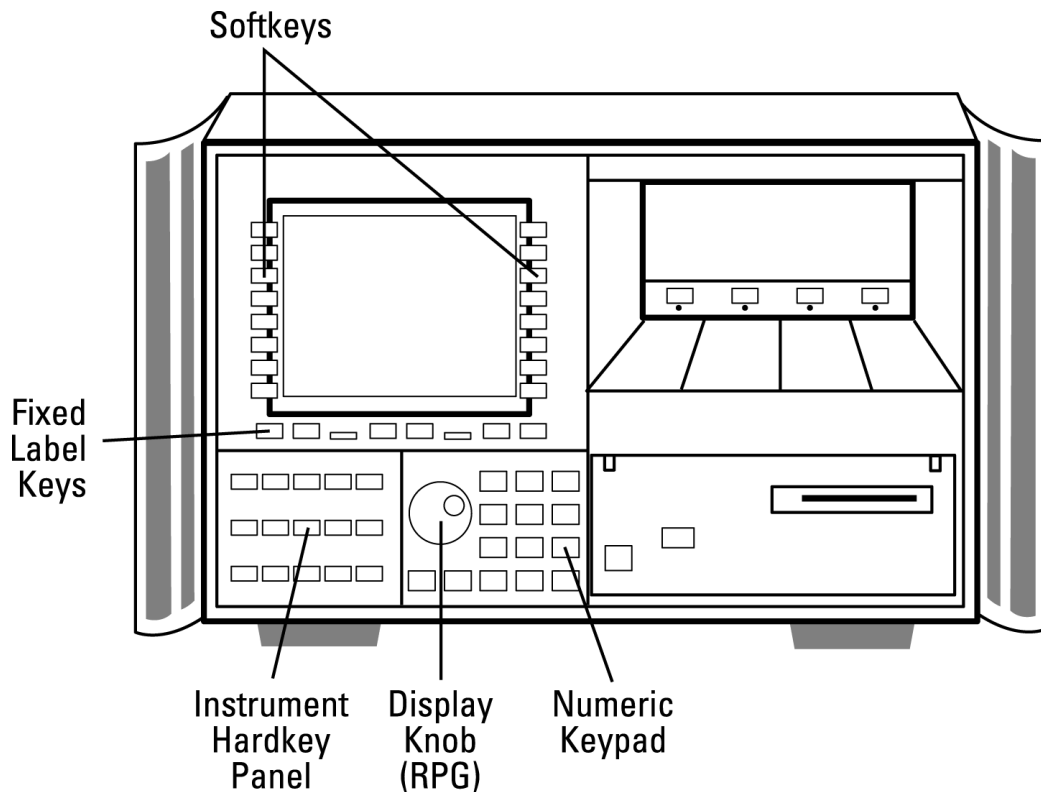

Figure 5-1 HP 70004A Display

### Key Notation

Throughout this manual **softkey** indicates softkey labels. Display fixed label keys and keys on the instrument hardkey panel are shown thus **FIXED LABEL** and **instrument hardkey**.



### Display Fixed Label Keys

Fixed Label keys select major system functions such as PRINT, PLOT, INSTR PRESET, DISPLAY or MENU. The two most important keys **DISPLAY** and **MENU** are explained on pages 5-4 and 5-5. Refer to the HP 70004A display Operation Manual for detailed information on fixed label keys.

### Instrument Hardkeys

Hardkeys are the keys on the panel to the left of the display knob (RPG knob). Use these keys to gain instant access to primary instrument functions.

### Parameter Control Keys

**Display knob** Use the display RPG knob to change parameters and select operating values.

**Numeric Keypad** Use the numeric keypad to enter numeric values.



Use the two step keys to change parameters up or down.

### Instrument Softkeys

The softkeys around the perimeter of the display screen are used to select instrument functions. The functions are organized in groups, called softkey menus.

---

**NOTE** Softkeys that are selected are displayed in inverse video or are underlined.

---

### Softkeys and Windows Color Coding

Softkeys and windows are color coded to indicate the primary instrument functions with which they are associated, they are:

- **blue softkeys/window:** assigned to Results Page occupies two thirds of screen.
- **green softkeys/window:** assigned to pattern generator/error detector configuration
- **yellow softkeys - green/yellow window:** assigned to Pattern Editor
- **grey softkeys/window:** assigned to user pattern selection and save.
- Softkeys that are “greyed out” are not valid for the currently selected instrument function.

### Multi-State Functions

Some softkeys switch between two states, such as **LOGGING OFF ON** and **SYNC AUTO/MAN**. An underline on the key labels indicates which keys and conditions are selected.

## To Set Up the Display

To configure the system correctly it is important to first set up the display, and then configure the display to show instrument status. System functions are therefore split into two groups as follows:

- Display Functions
- Instrument Functions

These functions are explained in the following paragraphs.

## Display Functions

Display functions are accessed using the **DISPLAY** fixed label key. Pressing the **DISPLAY** key provides the softkeys on the left and right of the display as shown below, enabling display functions to be set up. Refer to the HP 70004A display Operation Manual for detailed information on display operation softkeys.

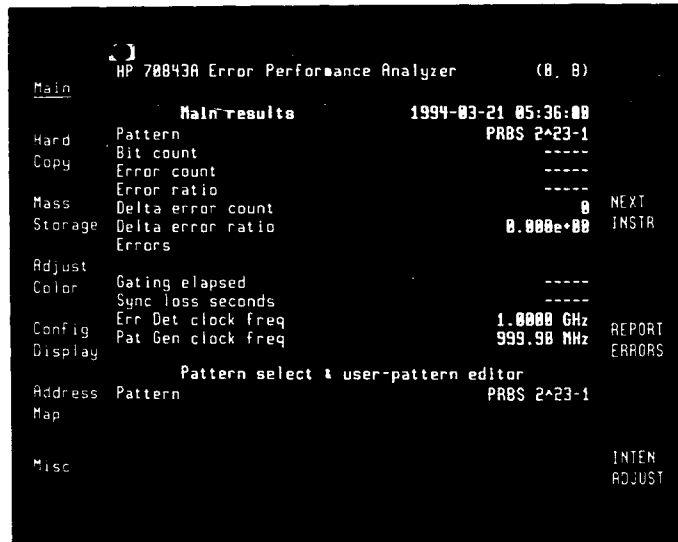

Figure 5-2 Display Softkeys

## Getting Started

### Instrument Functions

Primary Instrument functions are accessed using the keys on the instrument hardkey panel or by pressing the **MENU** fixed label key.

Both methods enable menus of softkeys which give access to all instrument functions. The following figure illustrates the primary instrument softkeys when **MENU** is pressed. For each softkey shown there is a corresponding key on the instrument hardkey panel, except for the **misc** softkey.

```
HP 70043A Error Performance Analyzer (8, 8)
-----
pattern  Main results 1994-03-21 05:37:00
data     Pattern      PRBS 2^23-1
output   Bit count      -----
         Error count  -----
         Error ratio  -----
clock    Delta error count
output   Delta error ratio 0
         Errors      0.000e+00
error    Gating elapsed -----
add      Sync loss seconds -----
         Err Det clock freq 1000000000 Hz
substrate Pat Gen clock freq 999.90 MHz
outputs  Pattern select & user-pattern editor
trigger  Pattern      PRBS 2^23-1
& setup
misc
```

Figure 5-3 Instrument Softkeys

## System Turn-On

### Introduction

The getting started procedures assume that the HP 71612 series systems have been correctly installed and configured as described in Chapter 2 *Installation*.

---

**WARNING** Before turning the system on, make sure it is grounded through the protective conductor of the ac power cable to a socket outlet provided with protective earth contact. Any interruption of the protective (grounding) conductor inside or outside the system, or disconnection of the protective earth terminal, can result in personal injury.

---

---

**CAUTION** Do not turn on the HP 71612 Series Systems until they have been configured and fused for the available line voltage, and safely connected to the power line (115V or 230V).

---

---

**CAUTION** Do not attempt to replace or remove clock modules while instruments are powered up as it may damage modules. Switch off the HP 70004A Display and if used the HP 70001A Mainframe before replacing or removing modules.

---

---

**NOTE** The HP 71612 Series Systems will not function correctly unless each instrument in the system is cabled correctly for HP-MSIB operation, and each instrument is powered up. Refer to Chapter 2 *Installation* for information on cabling.

---

## Making Your First Measurement

### Introduction

The following procedure is designed to give you confidence in using the instrument **hardkeys** and **softkeys** by performing a simple error measurement. It shows you how to cable the system and set up the error performance analyzer to perform a simple back-to-back error measurement. The procedure also introduces you to many of the instrument operating features.

### Procedure

Ensure that 50 $\Omega$  cables are used to connect the HP 70843 IN/OUT ports. All the cables, adapters and terminations you need are supplied with your instrument.

1. Connect the HP 70340A clock source RF OUTPUT port to the pattern generator CLOCK IN port.
2. Connect the pattern generator DATA OUT and CLOCK OUT ports to the error detector DATA IN and CLOCK IN ports respectively. Terminate any unused ports with 50 $\Omega$  terminations (HP part number 1250-2121). See Figure 5-4 on page 5-8. Ensure the HP 70843 error performance analyzer and HP 70004A display rear-panel HP-MSIB ports are connected.

### Initial Switch On

3. Switch on power to the HP 70843 and the HP 70004A display. All instrument and display LEDs will illuminate and then extinguish after a few seconds. The display will cycle through a range of colors, give a display indicating **HP 70004A DISPLAY** and a message stating **For instrument display press DISPLAY then NEXT INSTR**, and finally display the status of the instrument selected before the last power down. The ACT LED on the HP 70843 will be illuminated when it has control of the keyboard. Wait until the display settles to indicate instrument status before continuing with this procedure. If instrument status is not displayed, press **DISPLAY** then **NEXT INSTR**.

### Initial settings

4. Before you perform a measurement you must first configure the system to suit your application. Choose your own configuration using the instrument hardkeys and softkeys (refer to the pull-out card in the tray beneath the display for help) or select one of three stored predefined, complete instrument configurations. They are PRESET 0, PRESET 1 and PRESET 2.

## Getting Started

### Making Your First Measurement

To select PRESET 0 press the display **INST PRESET** key, and to select PRESET 1 or PRESET 2 select **trigger & setup**, **recall setup**, then **Preset 1** or **Preset 2**.

For this procedure we set the error performance analyzer to its default values by selecting PRESET 0. Refer to Chapter 9 for a list of settings for each PRESET.

5. Press the green **INST PRESET** key.

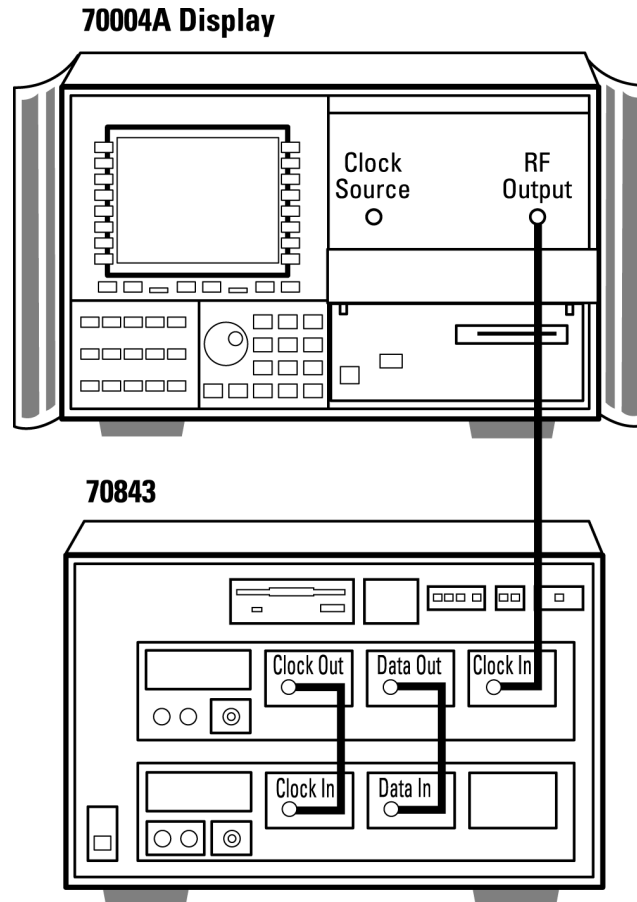

Figure 5-4 System Back-to-Back Connection

### Perform a data eye measurement

In the following steps the *data eye edge threshold* is set, and the clock and data inputs aligned such that the error detector samples in the middle of the *eye* (in the time axis).

6. Before performing the measurement select **result pages**, then select **EYE RESULTS**. No eye results will be displayed until clock-data alignment is performed in step 9 of this procedure.
7. Press the **input & eye** hardkey on the display hardkey panel.

## Getting Started

### Making Your First Measurement

#### Eye Edge Threshold

8. Set **0/1 THR AUTOMAN** to **AUTO** , then select **EYE EDG THRSHLD** and select a threshold using the numeric keypad. For example, to select a threshold of 1.00E-03; enter 1.00 using the keypad, then press the **e** softkey and enter 3 using the keypad, then press **ENTER** .
9. Press the **CLK-DAT ALIGN** softkey. If clock-to-data alignment is successful, the *Status* line at the center of the screen reads *clock to data input delay aligned*.

#### Automatic 0/1 Threshold Center

On data signals with an unequal mark-density perform an automatic 0/1 threshold center operation as follows:

10. After performing the clock to data alignment select the **0/1 THR CENTER** softkey. The *Status* line at the center of the screen will indicate *0/1 input threshold centering in progress* and *0/1 data input threshold centered* when complete.

#### To Select a Measurement Gating Period

11. Press the **gating** hardkey. The gating mode currently selected is MANUAL, try selecting a 20 second SINGLE gating period.
12. Press **SINGLE** , **GATE BY TIME** then **GATING PERIOD** , use the numeric keypad and **SECONDS** softkey to select a 20 second gating period. Proceed to step 13, or read the following note for alternative gating choices.

---

**NOTE**

The instrument is currently set to gate by time; two other gating period choices are also provided, they are: gate by errors and gate by bits. To select either of these gating choices select the appropriate softkey.

---

#### To Start a Measurement

13. Press the **RUN GATING** hardkey. Note the illuminated *Gating* LED on the error detector front panel and the *Gate* flag at the top right of the screen.

#### Viewing Results and Introducing Errors into the System

14. Since there were no errors introduced into the system there are no errors measured. To introduce errors into the system and obtain a meaningful result proceed as follows:
15. Select the **error add** hardkey. The instrument offers you the choice of adding single errors, errors at a fixed rate or errors from an external source. For this procedure select a fixed rate of 1E-5. Proceed to step 16.

## Getting Started

### Making Your First Measurement

#### To Select a Fixed Error Rate

16. Select **ERR-ADD FIXED**, then choose an error rate of 1E-5. The error detector front panel ERRORS LED will be ON and an **Errors** flag illuminated at the top of the screen.

#### To Add External Errors

Connect an external error signal source to the pattern generator ERROR INJECT INPUT. A single error is added to the data output for each rising edge at the input.

#### Start a New Measurement

17. Select **RUN GATING**

#### To View Measurement Results

18. Press **result pages** then **MAIN RESULTS** and view results at the end of the gating period. A typical results display is given in the following figure.

```
MAIN      HP 70043A Error Performance Analyzer      (0, 0)
RESULTS   Errors
          Main results      1994-03-21 05:38:20
OTHER     Pattern          PRBS 2^23-1
RESULTS   Bit count       19,999,956,640
          Error count     200,000
          Error ratio     1.000e-05
INTERVAL  Delta error count 1,000
RESULTS   Delta error ratio 1.000e-05
          Errors          ██████████
G. 021    Gating elapsed   0 d 0 h 0 m 20 s (100x)
RESULTS   Sync loss seconds 0
          Err Det clock freq 990000 MHz
EYE       Pat Gen clock freq 999.98 MHz
RESULTS

          Pattern Generator error-addition control
          Error-add source   fixed
          Error-add rate     1e-5

USER'S
PAGE
```

19. The error detector (Main Results) are displayed; this is only one of seven result pages you can select to view instrument status or configuration.

20. Try selecting each of the **result pages** softkeys and view the error detector results for each selection.

This concludes your first measurement using an HP 71612 Series error performance analyzer.



---

## To Verify/Demonstrate the Capture Error Feature (Option UHJ instruments)

The following procedure can be used to demonstrate capturing an error, or verify that the instrument is operating correctly in this mode. It also teaches you how to select an alternate pattern and add errors to one half of the alternate pattern.

### Procedure

For this procedure an alternate pattern is selected and errors added to pattern B.

1. The procedure assumes that the HP 71612 is correctly installed; all MSIB cables are connected and the HP 70843 is connected back to back - pattern generator CLOCK OUT and DATA OUT connected to error detector DATA IN and CLOCK IN. Also connect the clock source RF OUTPUT to the pattern generator CLOCK IN port.
2. Select **pattern** , **edit ram usr** then an **INTERNAL PATT** store - for this example select **INTERNAL PATT1** .
3. Set **ALT PAT ON OFF** to **ON** then select **YES** . This sets the length of the pattern in **INTERNAL PATT1** to 1.
4. Select **SETPAT LENGTH** then enter a pattern length of 4000 using the numeric keypad - press **ENTER** . If you press **toggle screen** you can view the pattern on a full screen.
5. Check that the **INSERT REPLACE** key is set to **REPLACE** .
6. Load a PRBS into each half of the alternate pattern as follows:
7. Set the cursor on bit 0 of half A (half A is the uppermost pattern) then select **load block, 2^13 prbs , NO MODIFY** .
8. Use the **▼** and **goto** keys to set the cursor on bit 0 of half B.
9. Select **load block, 2^13 prbs , NO MODIFY** . Add errors to pattern B by changing bits 224 and 560.
10. Select **save pattern, INTERNAL PATT1** .
11. Select **pattern** and set **ALTPAT AUX USR** to **USR** and **ALTPAT HALF AB** to **B** . Note that the red **Errors** flag is illuminated.
12. Select **error location** and press **CAPTURE ERROR** . Note that the Bit error address in the Error location configuration control window indicates an error in bit 224, - press **CAPTURE ERROR** again and the address changes to 560. Note the captured error positions depend upon the initial state of the instrument error registers. The error positions given could possibly be reversed in order.
13. End of procedure.



---

**Softkey Menu Maps**

---

## Introduction

The display instrument hardkey panel (when fitted) and the softkeys displayed when the **MENU** key is selected are used to select all major instrument functions. The following menu maps illustrate the softkey choices for each function or group of functions.

The boxes shown on the charts represent actual key presses and illustrate the sequence of key presses necessary to perform individual functions.

## Menu Map when MENU hardkey Selected

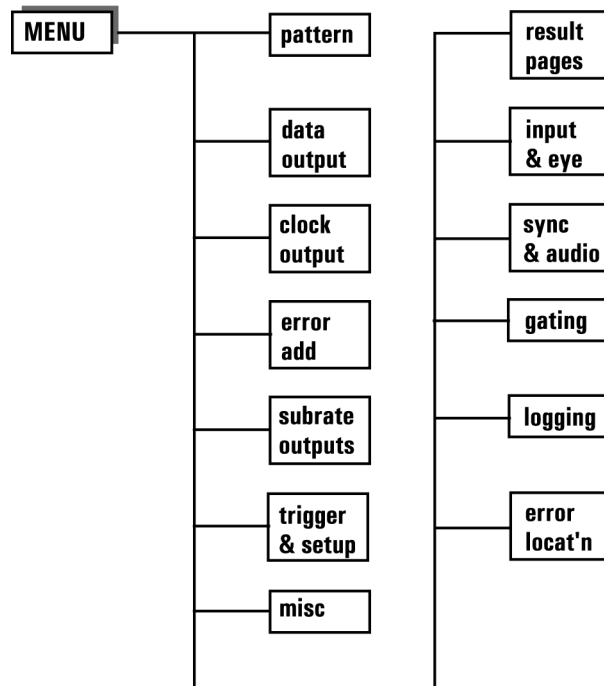

### Menu Map when Result Pages hardkey Selected

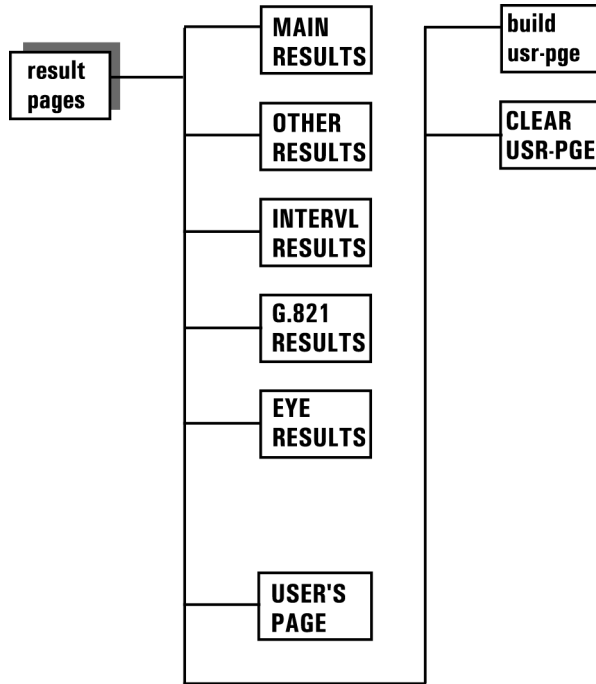

### Menu Map when Pattern hardkey Selected

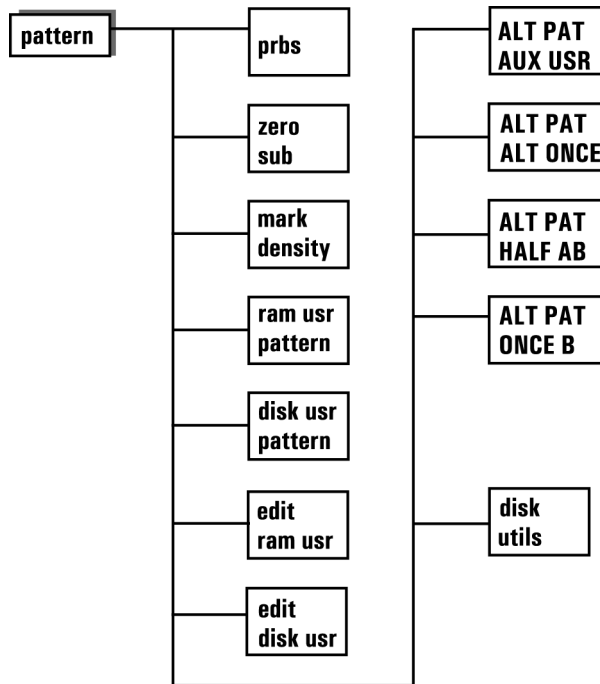

## Softkey Menu Maps

### PRBS Menu Map

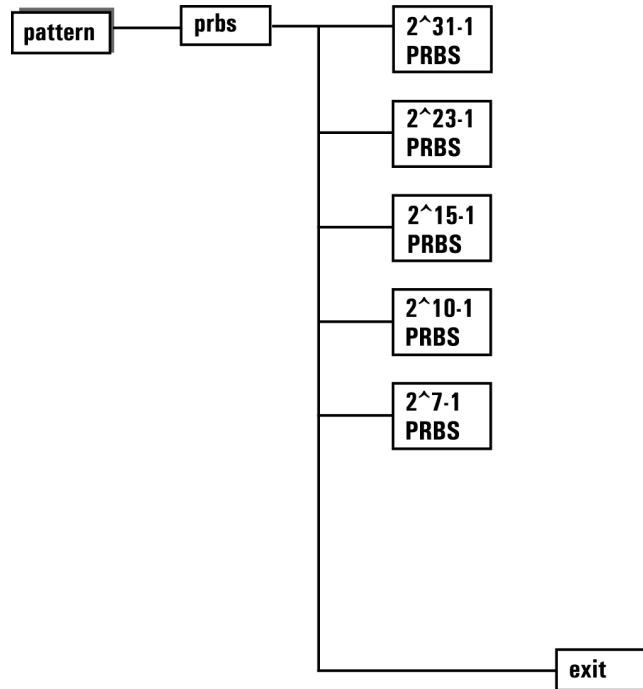

### Zerosub Menu Map

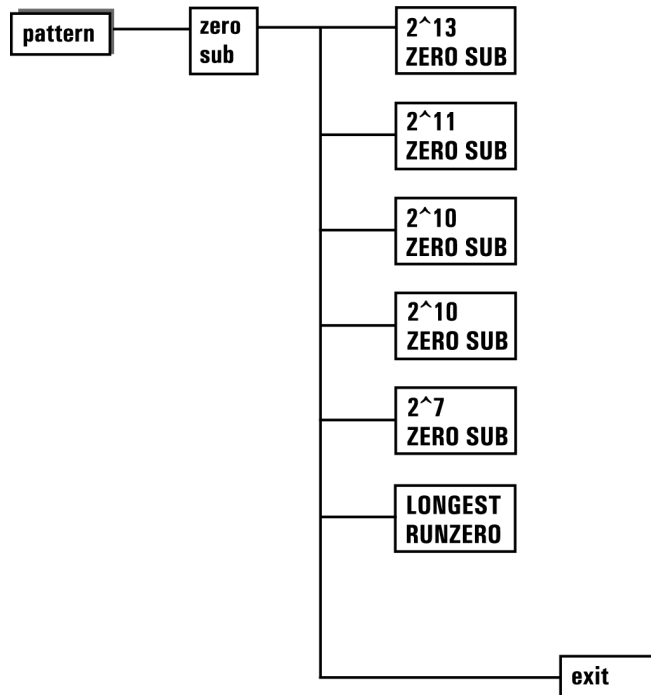

## Softkey Menu Maps

### Markdensity Menu Map

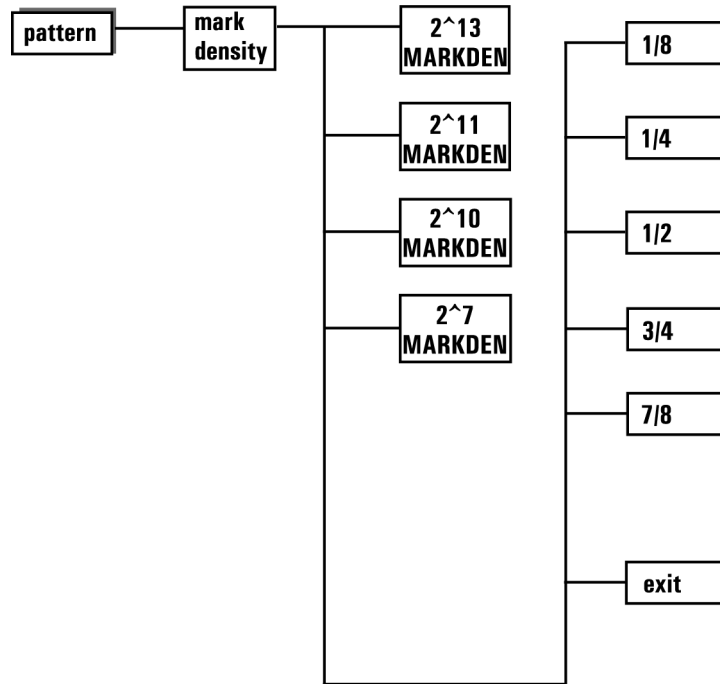

### Ram User Menu Map

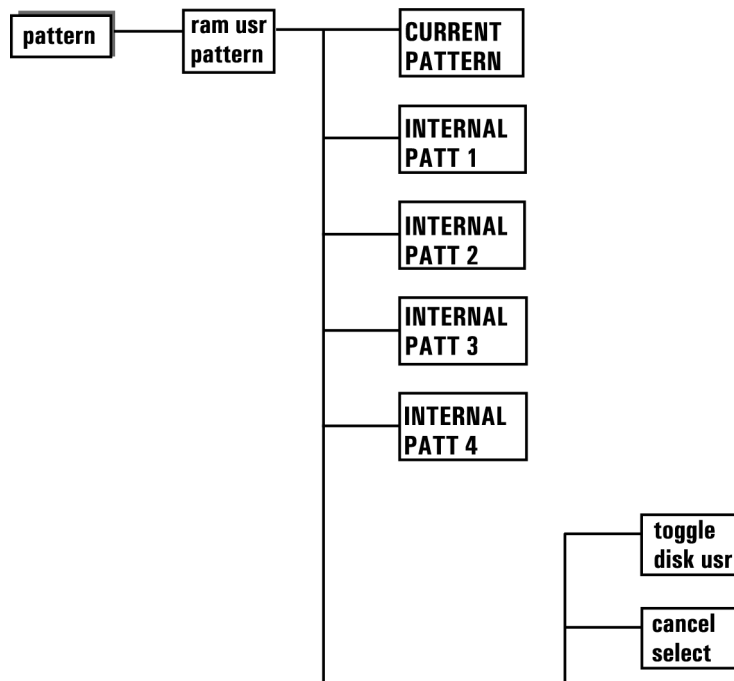

## Softkey Menu Maps

### Disk User Menu Map

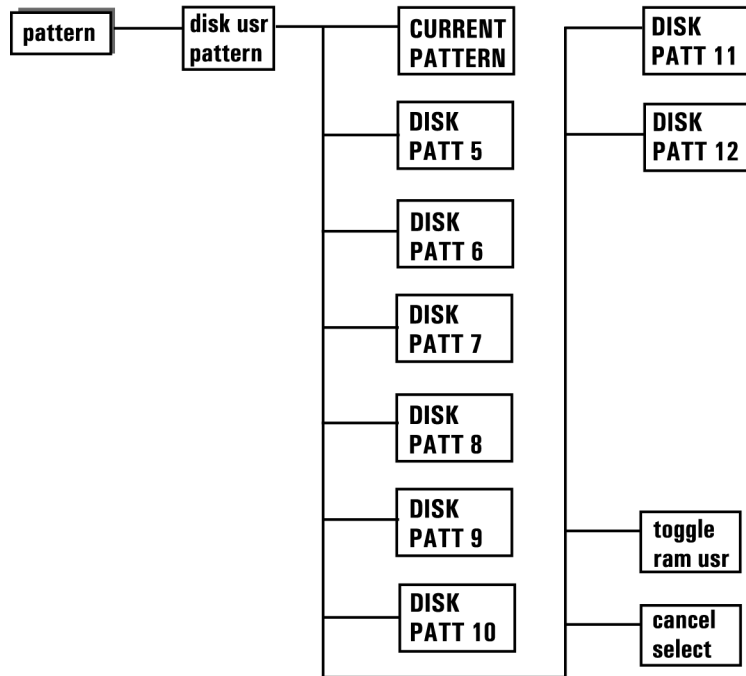

### Disk Utils Menu Map

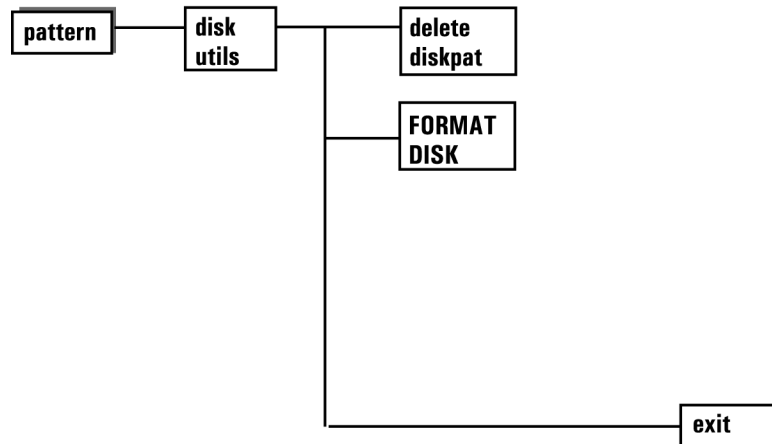



## Softkey Menu Maps

### Edit Ram User Menu Map

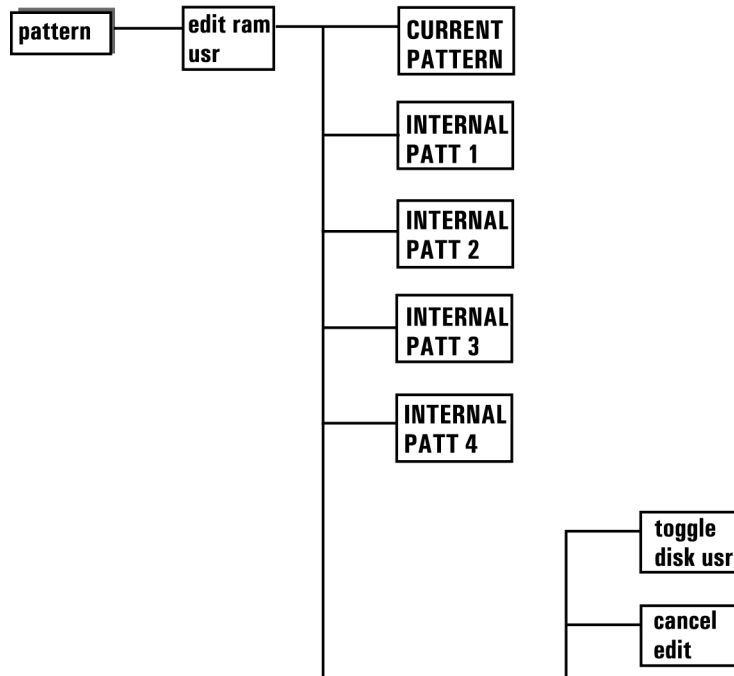

### Edit Disk User Menu Map

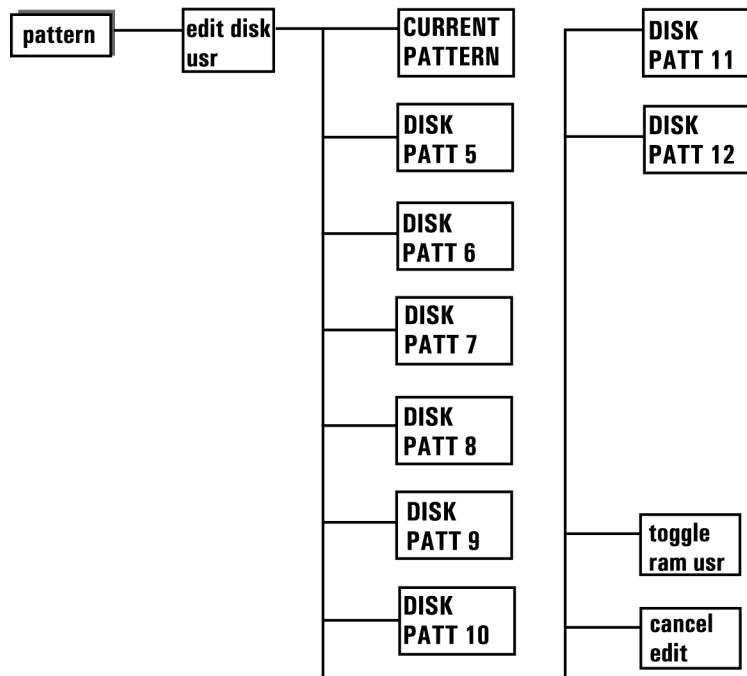

## Softkey Menu Maps

### Edit User Menu Map

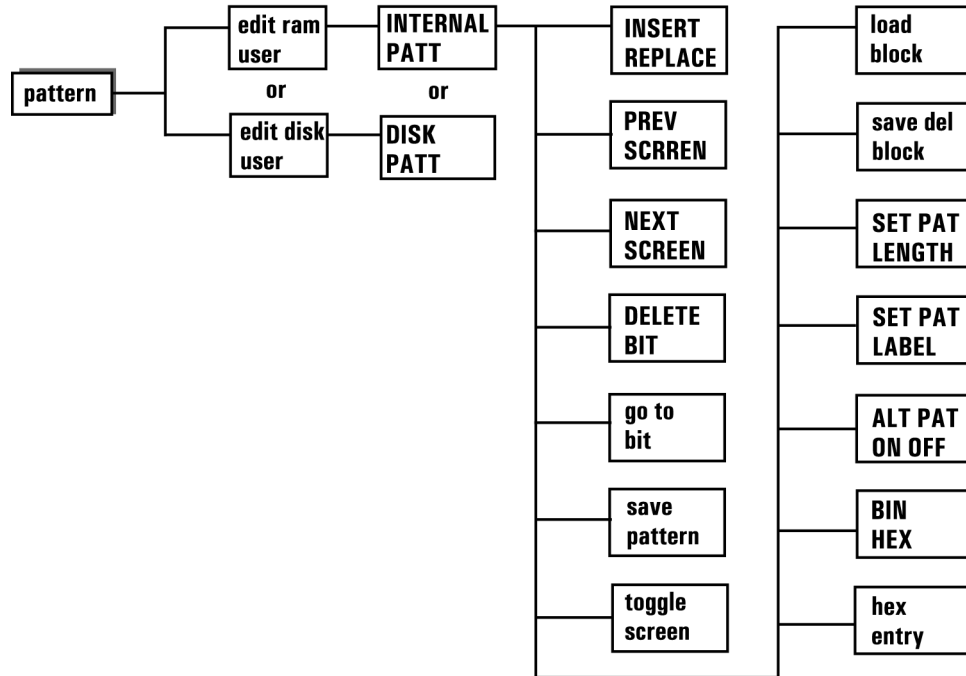

### Data Output Menu Map

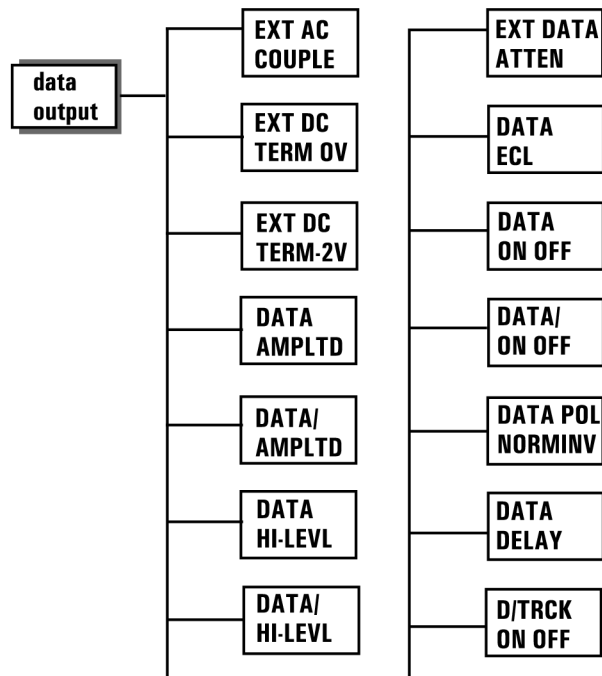

### Clock Output Menu Map

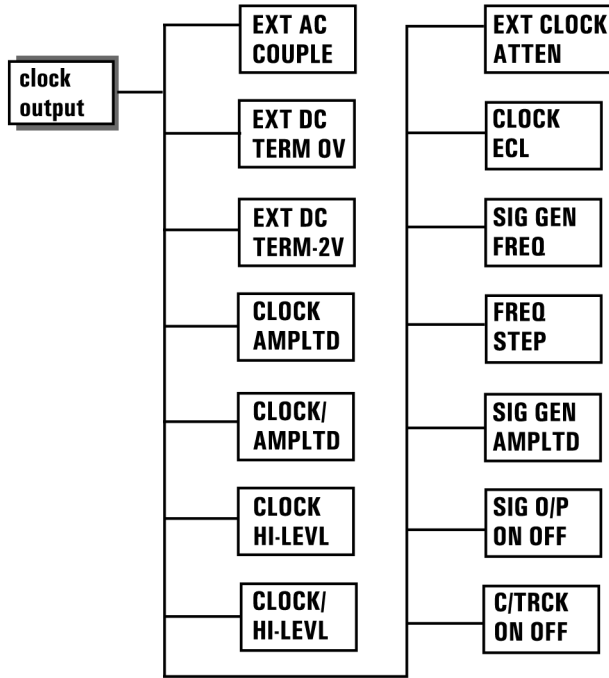

### Error Add Menu Map

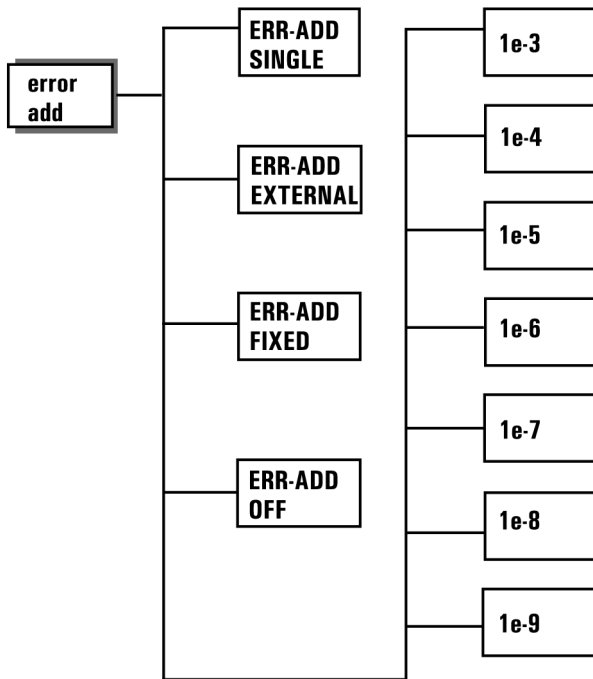

### Subrate Outputs Menu Map

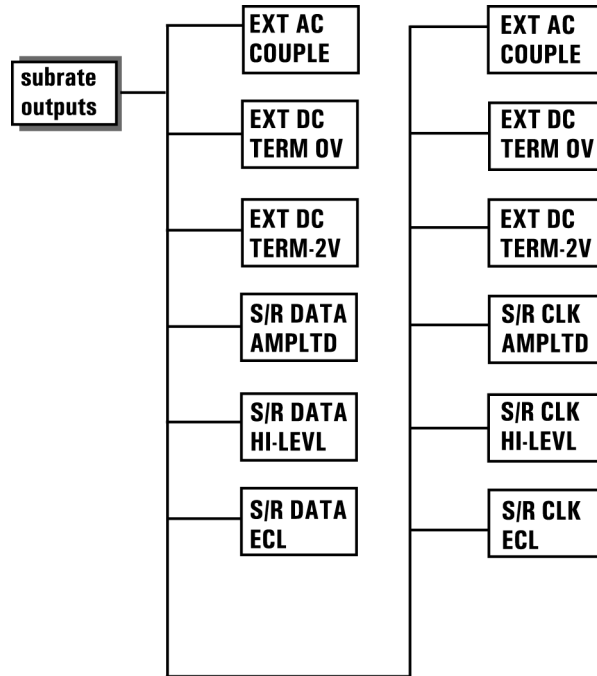

### Trigger & Setup Menu Map

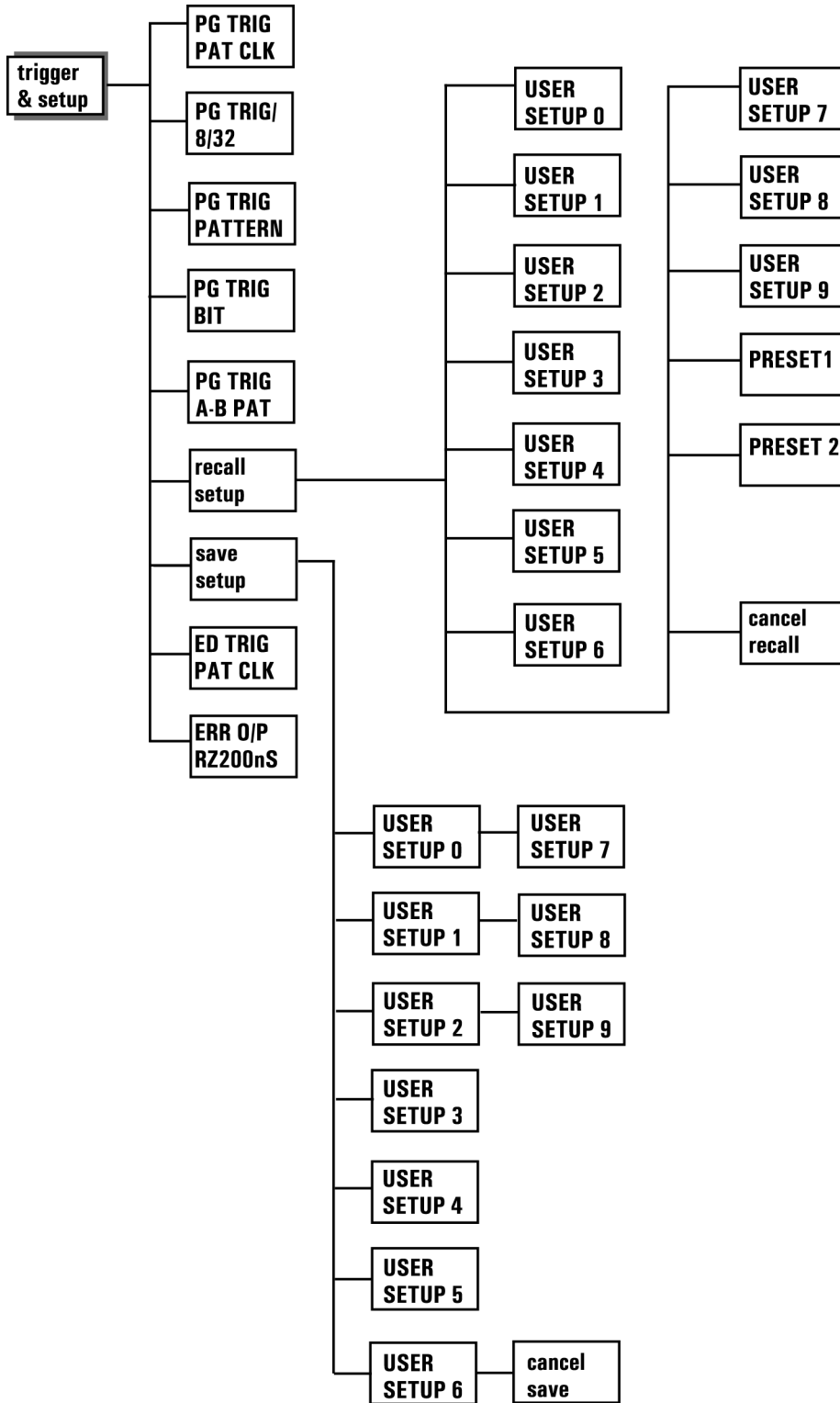

## Softkey Menu Maps

### Miscellaneous Menu Map

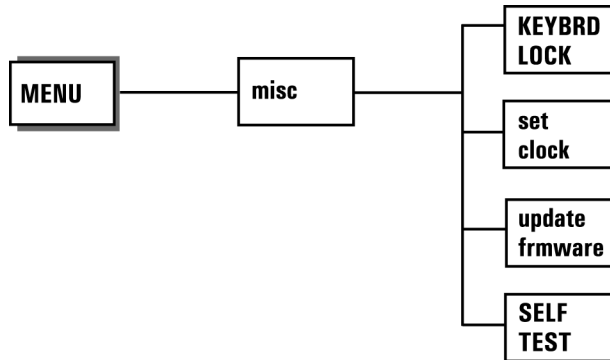

### Input & Eye Menu Map

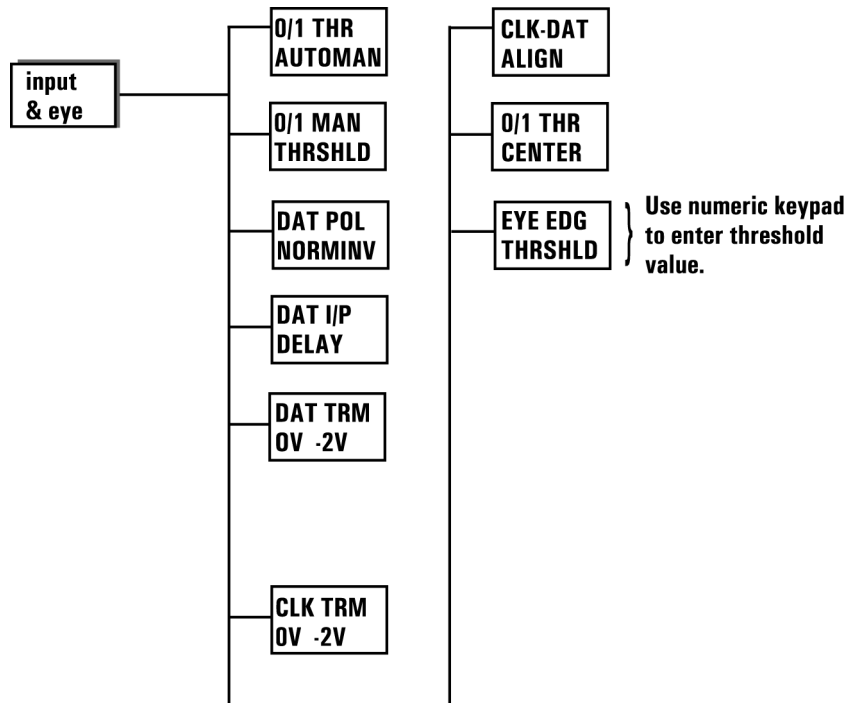

### Sync & Audio Menu Map

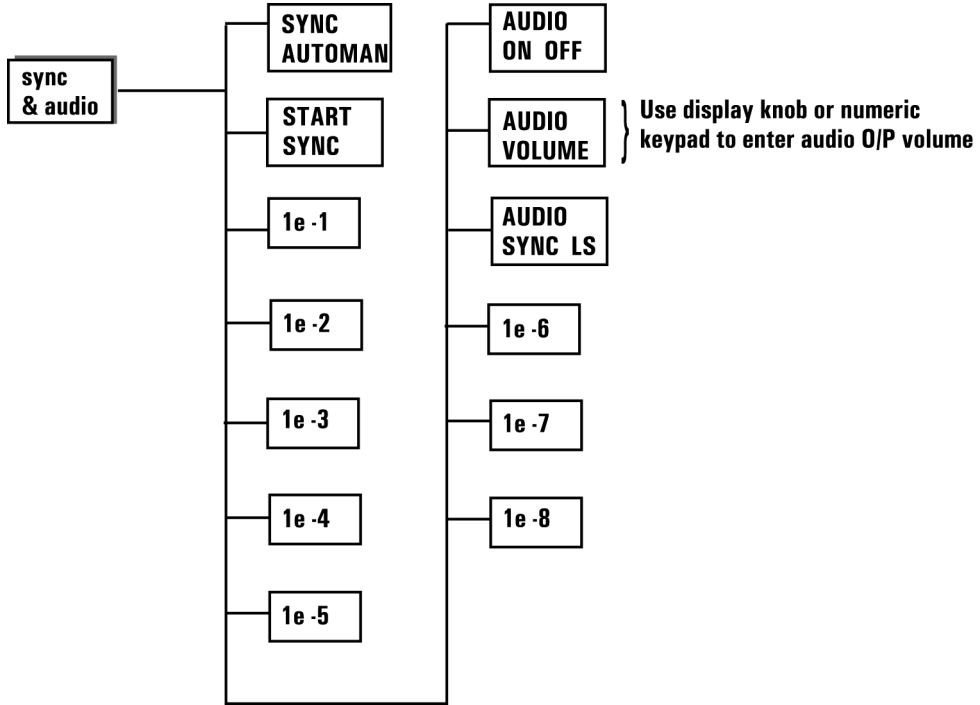

## Gating Menu Map

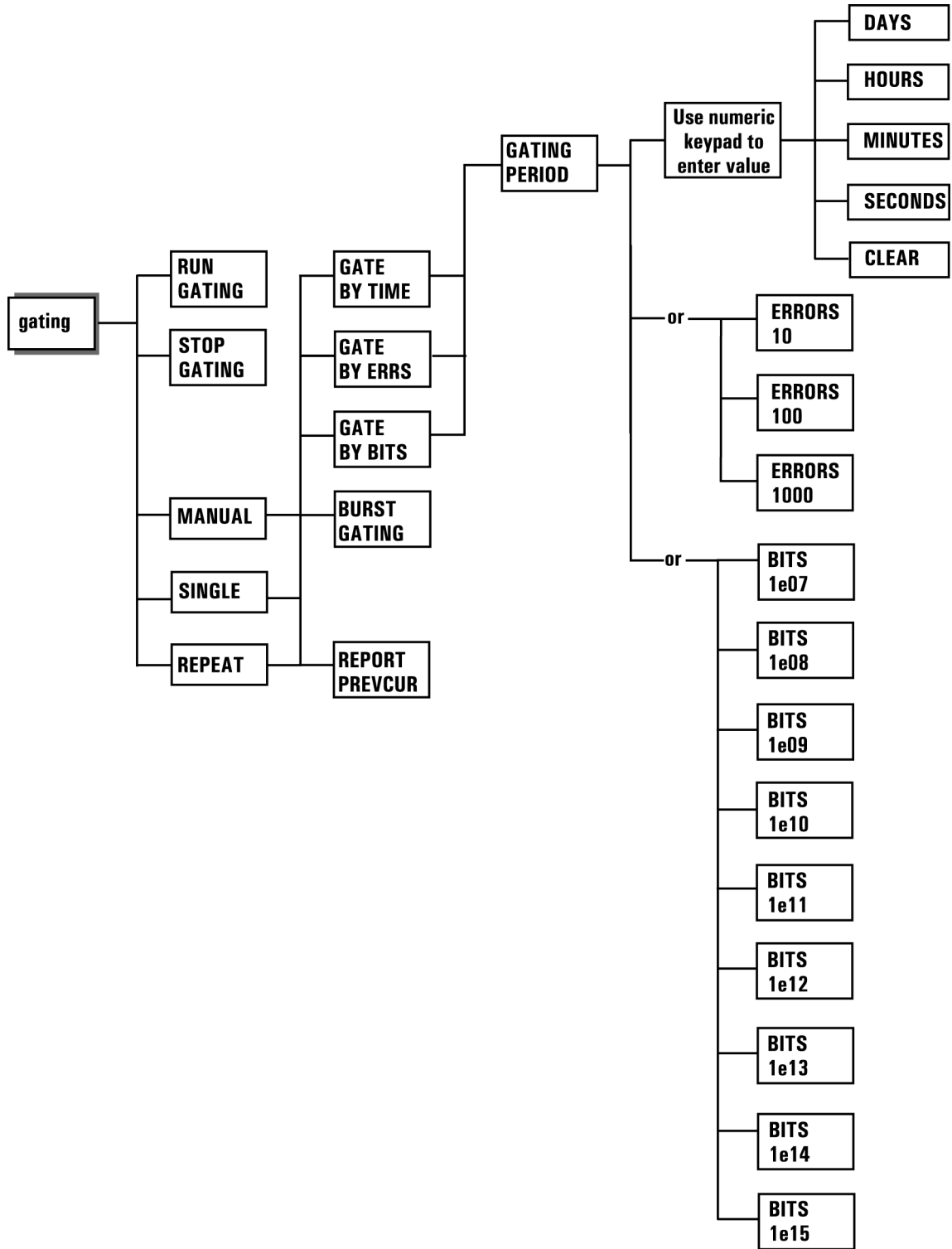



### Logging Menu Map

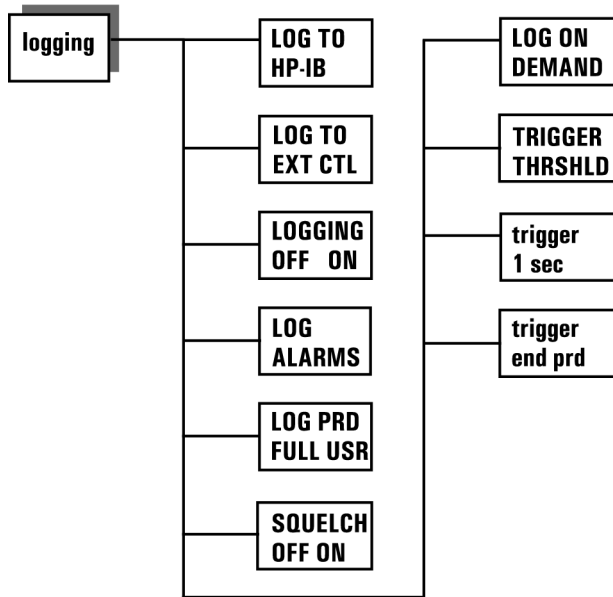

### Error Location Menu Map

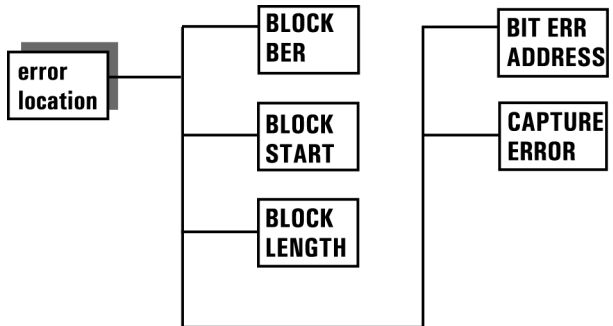

### Build User Page Menu Map

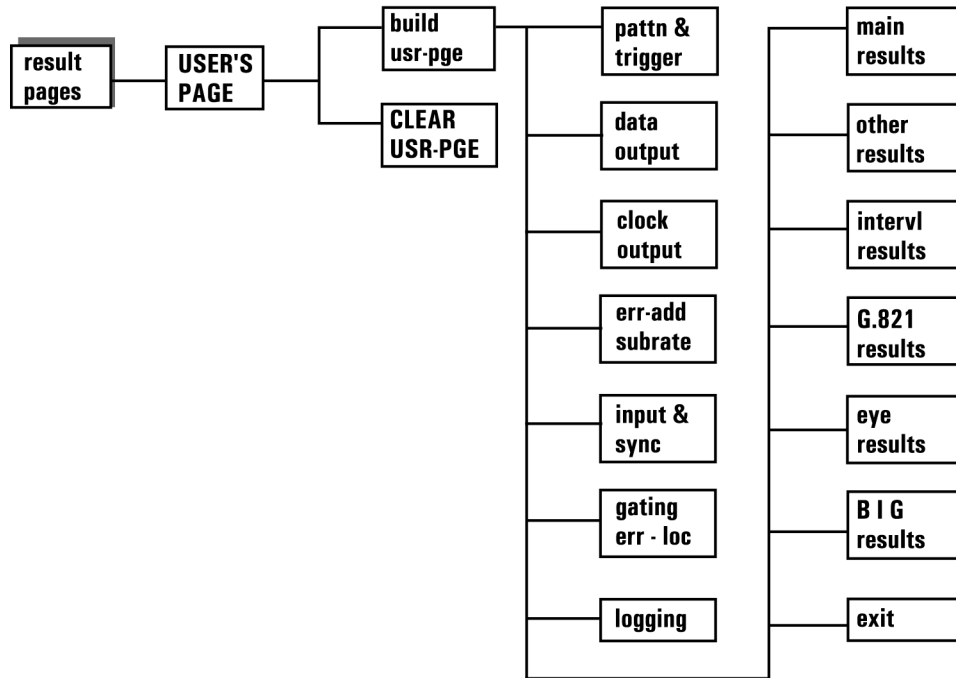

### Build User Page Pattern & Trigger Menu Map

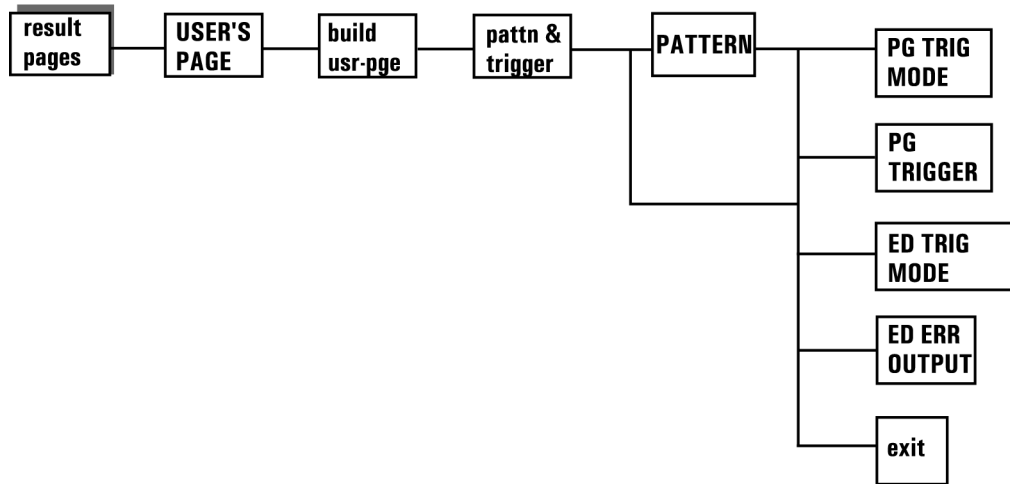

### Build User Page Data Output Menu Map

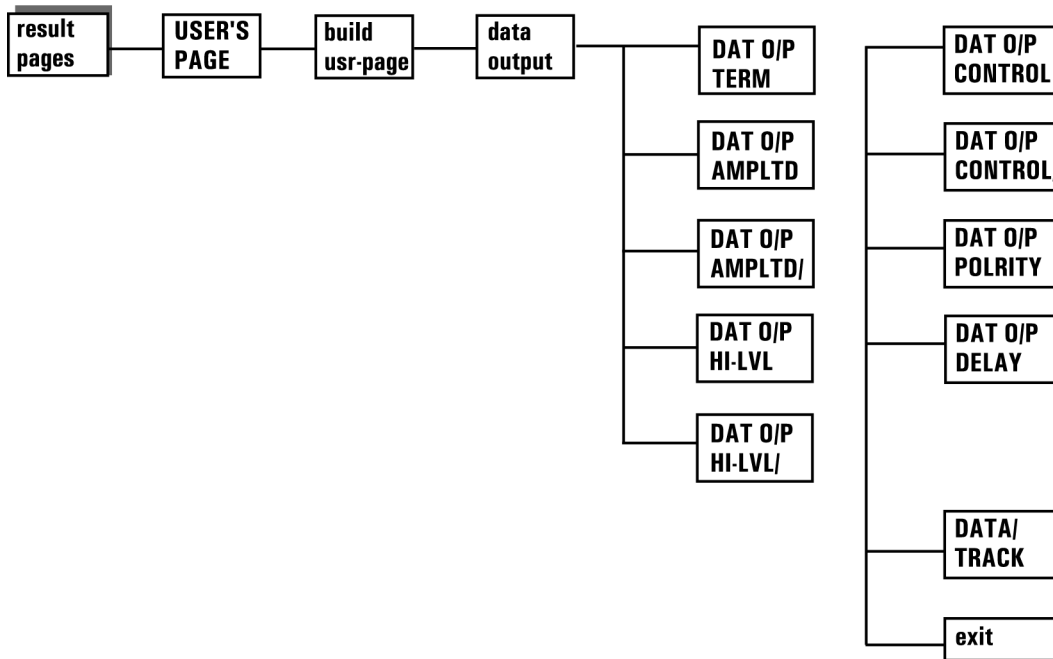

### Build User Page Clock Output Menu Map

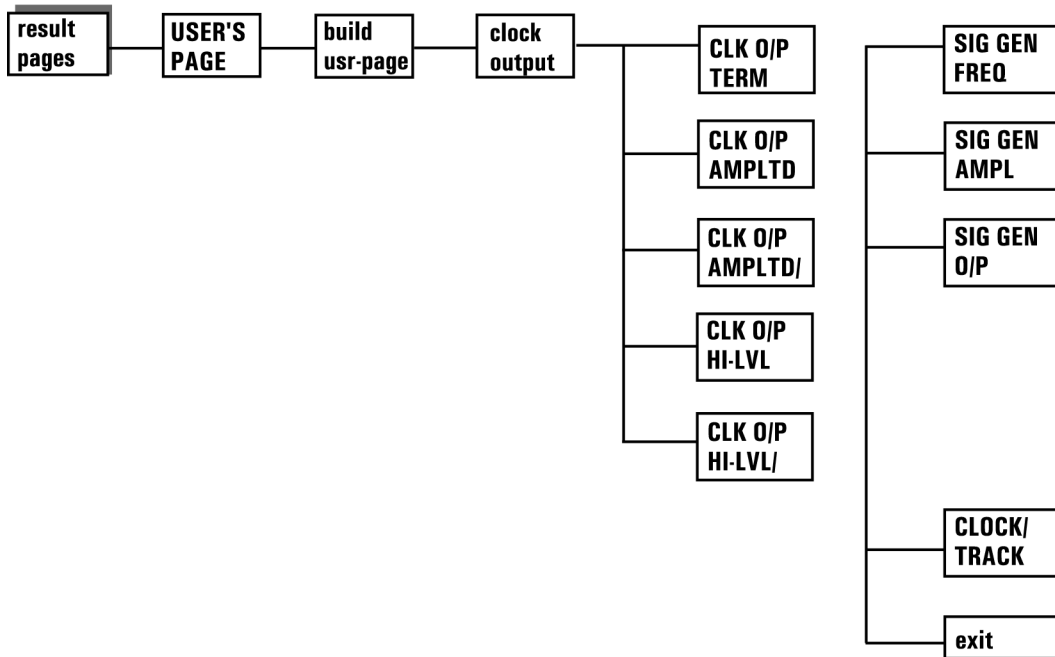

### Build User Page Error Add Subrate Data/Clock Menu Map

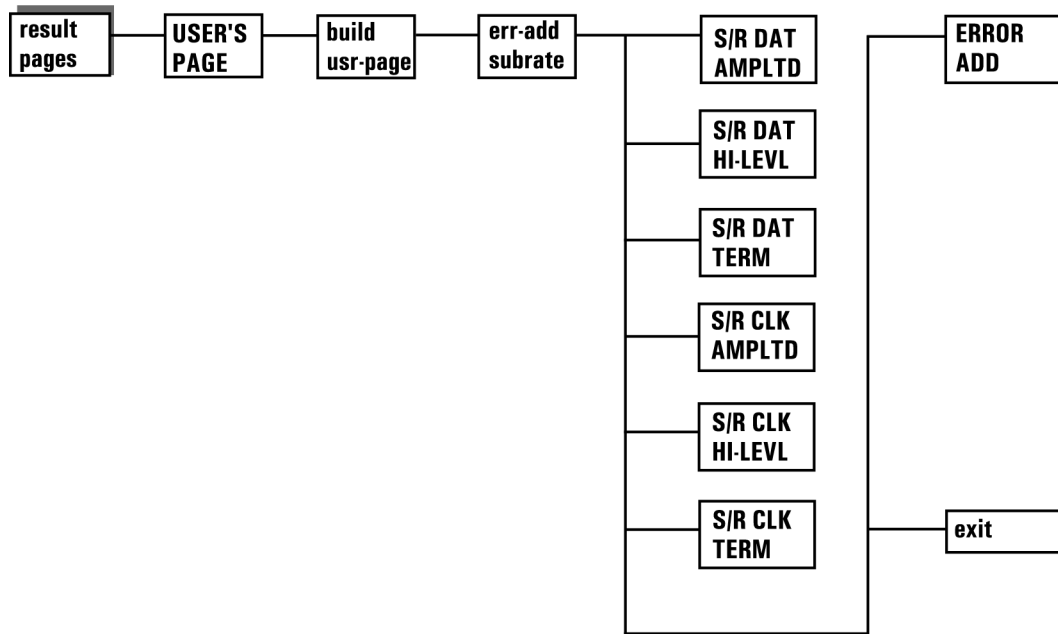

### Build User Page Input and Sync Menu Map

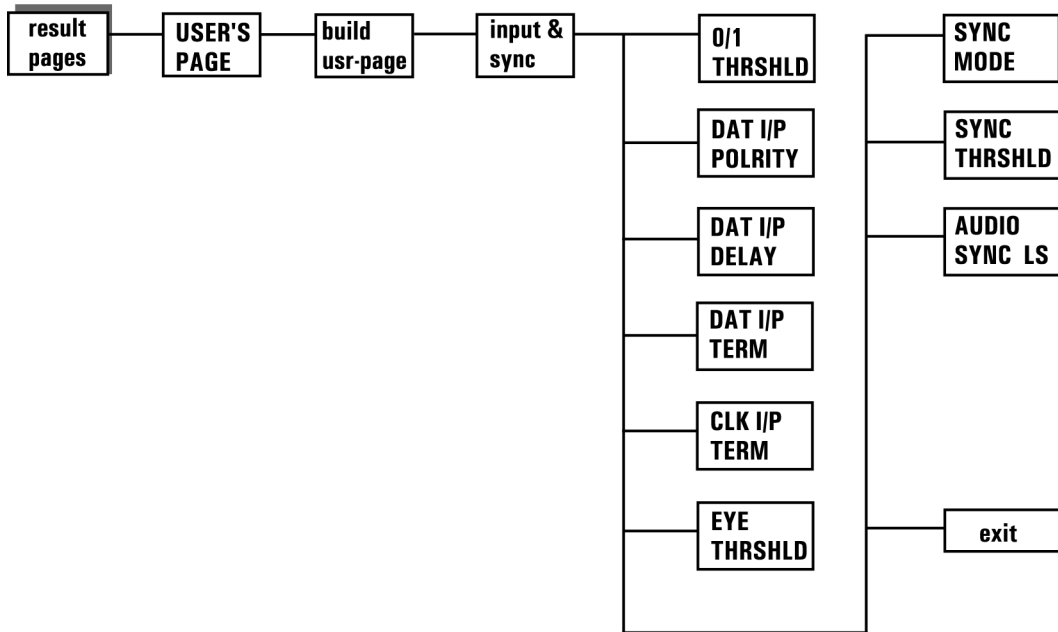

## Softkey Menu Maps

### Build User Page Gating and Error Location Menu Map

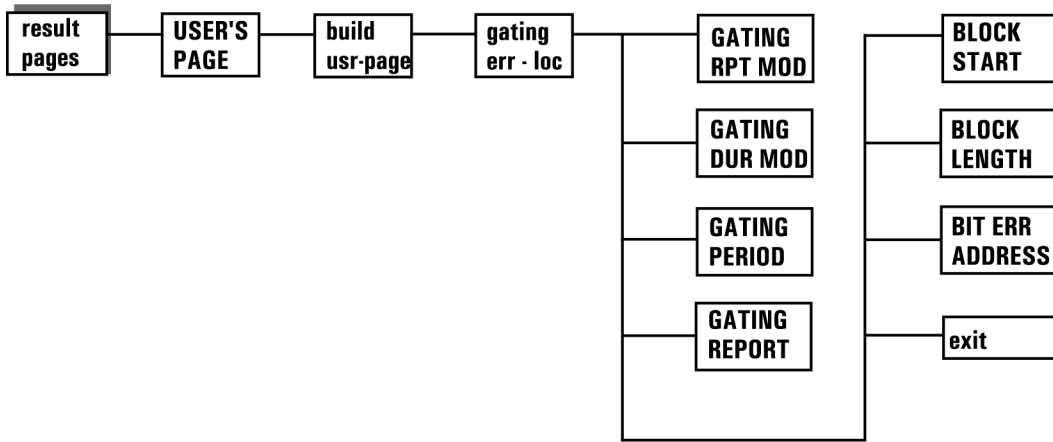

### Build User Page Logging Menu Map

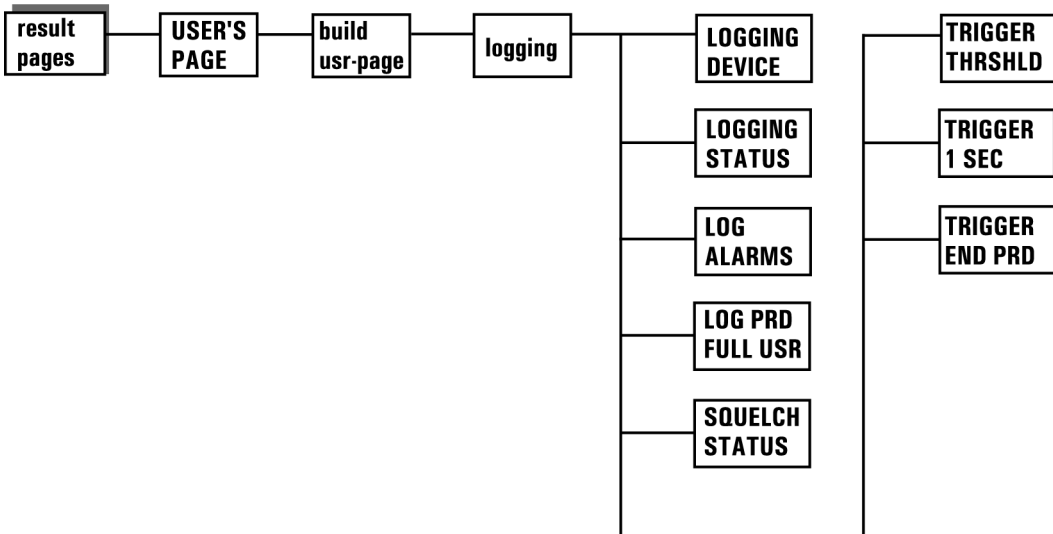

### Build User Page Main Results Menu Map

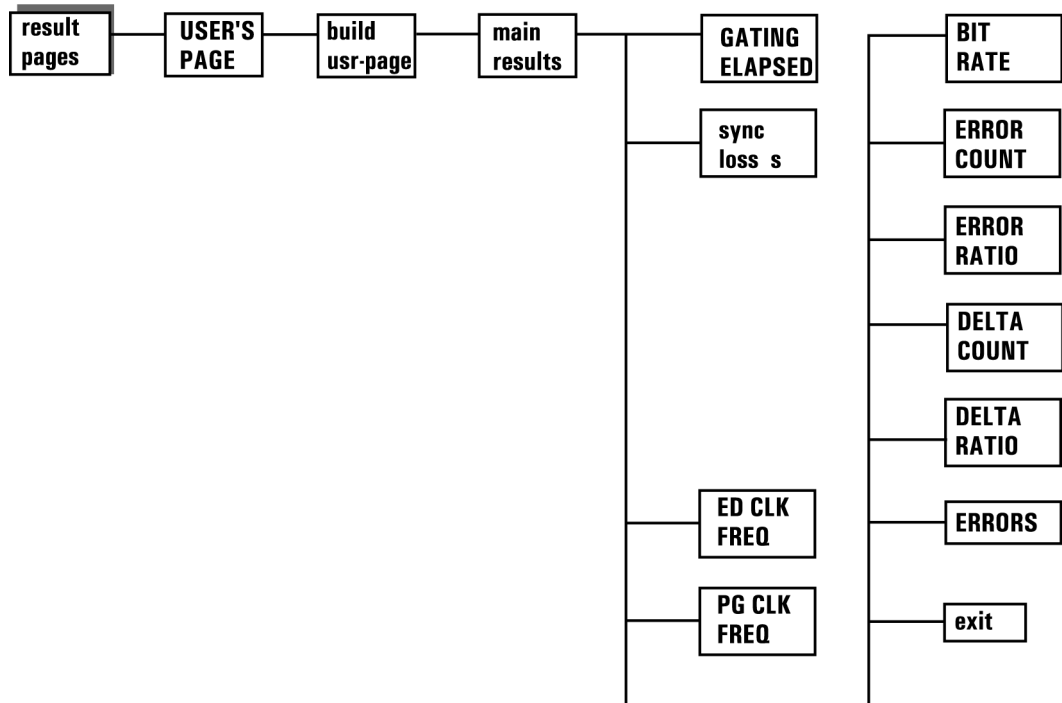

### Build User Page Other Results Menu Map

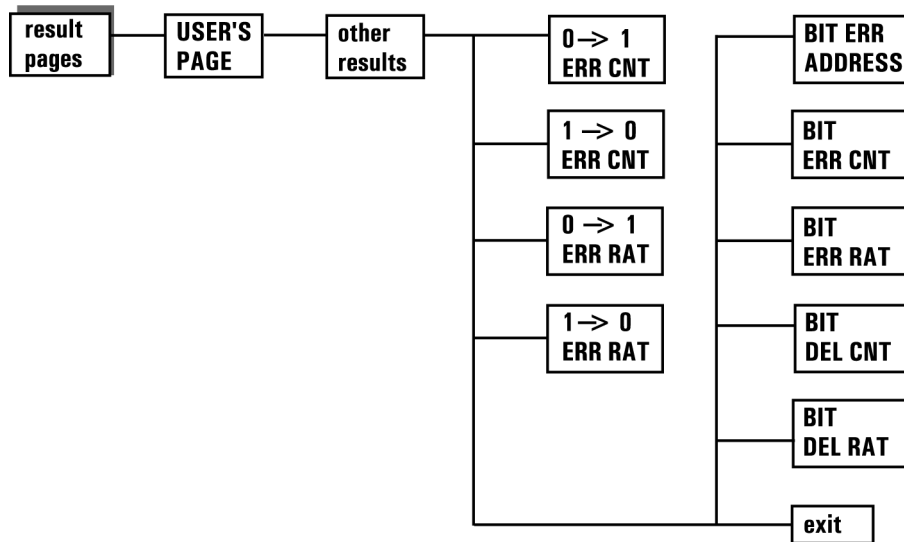

### Build User Page Interval Results Menu Map

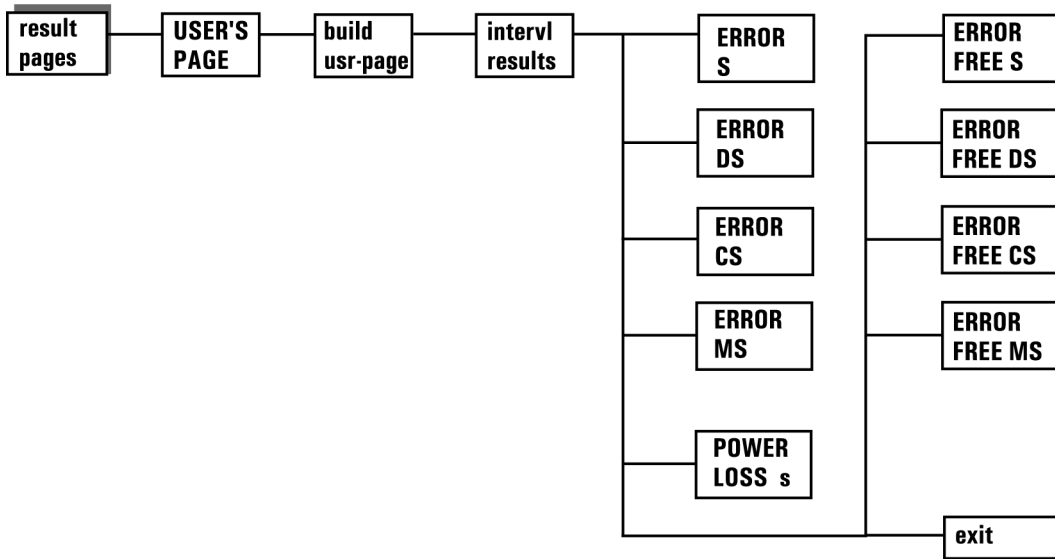

### Build User Page G.821 Results Menu Map

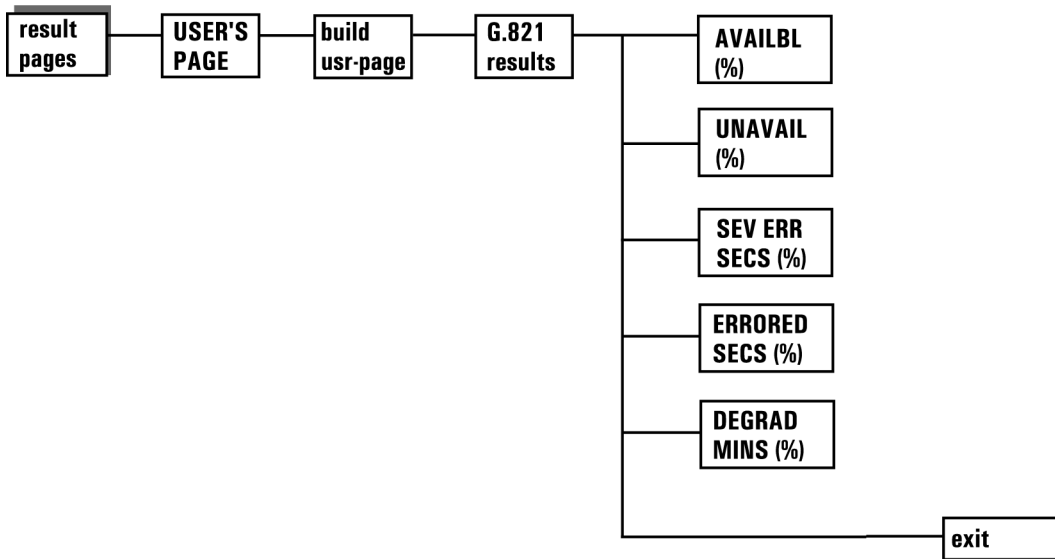

### Build User Page Eye Results Menu Map

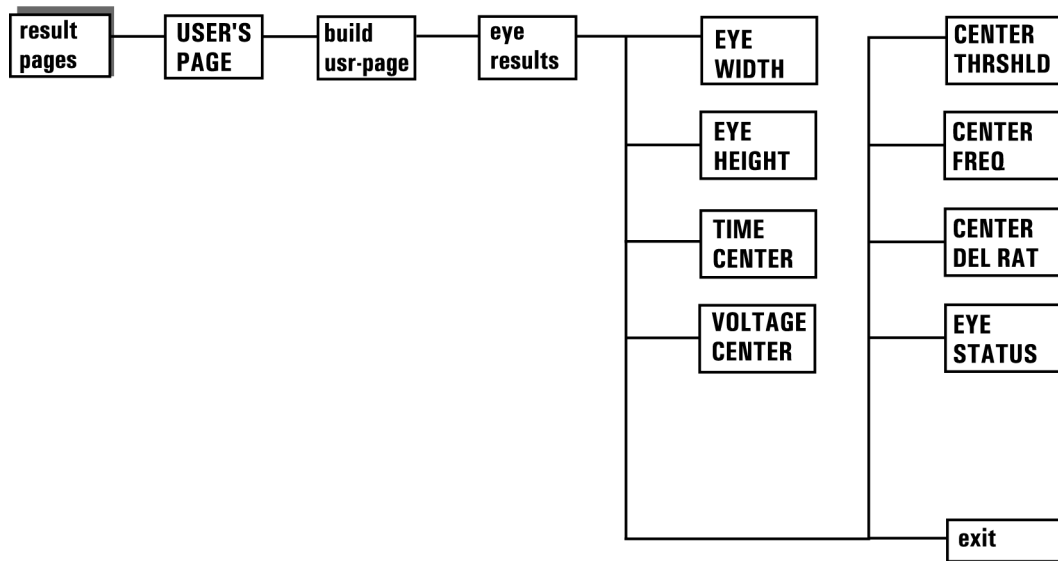

### Build User Page Big Results Menu Map

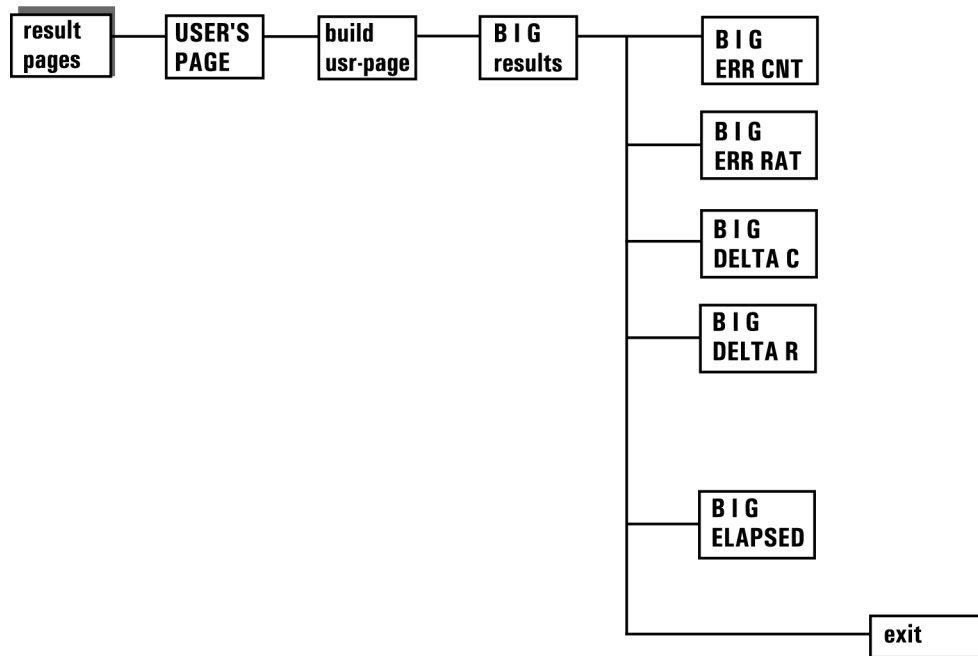



---

## **Softkey Menu Descriptions**

## Introduction

This section gives a brief introduction to using softkeys, and gives detailed descriptions of each softkey.

## Softkey Menus

In HP 71612 Series error performance analyzer systems instrument softkeys are the seven keys to the right and left of the HP 70004A display. These keys provide menus of softkeys which are used to access all instrument functions/parameters. The hardkeys on the keyboard at the bottom left of the display and the **USER** or **MENU** keys give quick access to the *primary level* softkeys. Primary level softkeys are used to select major functions or groups of functions. All *primary level* softkeys that are displayed when **USER** or **MENU** are selected, with the exception of the **misc** key, can be selected via the instrument hardkey panel.

### Softkeys requiring numeric entry

Those keys requiring the entry of a numeric value will usually have subordinate keys, which specify the units of the parameter being set as well as a **CLEAR** function to allow the user to leave the value unchanged.

### Softkey Labelling

Softkey labelling follows the convention that lower-case indicates that the key is a *navigation* key, giving access to a lower-level menu; whilst upper-case is used for a *configuration* key which allows the configuration to be changed.

### Softkeys Color Coding

Softkeys and windows are color coded to indicate the primary instrument functions with which they are associated. They are:

- **blue softkeys/window:** assigned to Results Page, occupies two thirds of screen
- **green softkeys/window:** assigned to pattern generator/error detector configuration
- **yellow softkeys - green/yellow window:** assigned to Pattern Editor
- **grey softkeys/window:** assigned to user pattern selection and the save function.

Softkeys that are “greyed out” are not valid for the currently selected instrument function.

## Primary Softkeys

The following figure illustrates the softkey menu when the display **MENU** or **USER** hardkeys are selected.

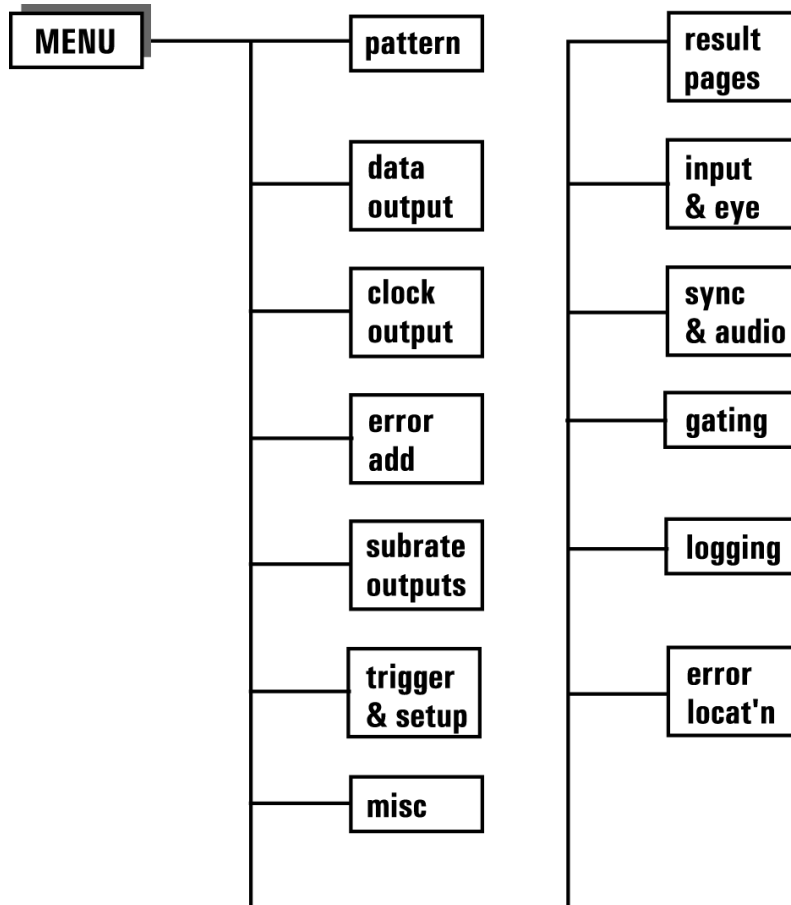

## Path Selection

In the following softkey descriptions the **Path** illustrates the key selections necessary to access a softkey menu. In all cases except the **misc** menu there are two methods of selecting a primary softkey menu as follows:

- For HP 70004A displays with an instrument hardkey panel fitted (for example **pattern** and **data output**) select a **hardkey** and the corresponding softkey menu will be displayed.
- For HP 70004A displays without an HP 71612 hardkey panel fitted, select **MENU** then the appropriate softkey.
- Hewlett-Packard strongly recommends that a hardkey panel is fitted. Ease of use is greatly enhanced. Order part number 70843-60033.

## Pattern Softkey Menus

### Path

`pattern` or `MENU pattern`

### Description

The `pattern` softkey enables menus of softkeys allowing the user to select from the following:

- One of five PRBS patterns - unmodified, or with zero substitution or mark density modification
- One of four internal RAM-based User patterns
- One of eight disk based User patterns
- Access a powerful editor which enables the user to recall, edit and save any User pattern

The `pattern` softkeys are as follows:

`pattern`, `prbs`

`231-1 PRBS`

`223-1 PRBS`

`215-1 PRBS`

`210-1 PRBS`

`27-1 PRBS`

Enables the user to select one of five pure Pseudo-Random Binary Sequences, PRBS. The expressions represent the lengths of the patterns, in bits.

`pattern`, `zero sub`

`213 ZEROSUB`

`211 ZEROSUB`

`210 ZEROSUB`

`27 ZEROSUB`

Select from one of four modified PRBS which are Pseudo-Random Binary Sequences with an extra zero added to the longest run of zeros, and with a run of zeros (Zero Substitution) being substituted for the normal bits that follow the longest run of zeros in the pattern.

`LONGEST RUNZERO`

Enables the user to set the total length of the longest run of zeros. The longest run can be extended to the pattern length, minus 1. The bit after the substituted zeros is set to 1. This key is only enabled when a ZEROSUB pattern is selected.

**Softkey Menu Descriptions**  
**Pattern Softkey Menus**

**pattern**, mark density

**2<sup>13</sup> MARKDEN**

**2<sup>11</sup> MARKDEN**

**2<sup>10</sup> MARKDEN**

**2<sup>7</sup> MARKDEN**

Select from one of four modified Pseudo-Random Binary Sequences which have an extra zero added to the longest run of zeros, and with a modified Mark Density.

**LONGEST RUNZERO**

Enables the user to set the total length of the longest run of zeros. The longest run can be extended to the pattern length, minus 1. The bit after the substituted zeros is set to 1. This key is only enabled when a ZEROSUB pattern is selected.

**1/8, 1/4, 1/2**

**3/4, 7/8**

Enables the user to set the value of the mark density by selecting a value from the choices given. These represent the ratio of marks to the number of bits in the pattern.

**exit**

Returns the user to the main (pattern) menu.

**pattern**, ram Usr pattern

**ram Usr pattern**

The choice of patterns are four RAM-based patterns (numbers 1 to 4) of length up to 8192 bits and the CURRENT PATTERN.

**toggle disk usr**

Use this key to switch between a display listing RAM user or disk based patterns.

---

**NOTE**

If you select a user pattern ensure that the sync threshold is compatible with the pattern being generated. Failure to set the correct sync threshold may result in incorrect synchronization. Incorrect synchronization results in errors and may cause clock-to-data alignment failure.

---

**pattern**, diskUsr pattern

**diskUsr pattern**

Select one of eight floppy disk based patterns (numbers 5 to 12) and the CURRENT PATTERN.

**toggle ram Usr**

Use this key to switch between a display listing RAM user or disk based patterns.

## Softkey Menu Descriptions Pattern Softkey Menus

### Edit User Pattern Menu (RAM or disk)

#### Path

**pattern**, **edit ram usr** or **edit diskusr**

#### Description

The **edit ram usr** and **edit diskusr** softkeys access the editor used to modify the user-defined patterns. When the **edit ram usr** softkey is pressed the contents of the user pattern stores (including labels and lengths) are displayed as shown in the following examples. If one of the user patterns is the pattern currently being output, the display indicates ACTIVE at the top right of the pattern editor window. If the **edit diskusr** key is pressed, a list of disk patterns is displayed. The **toggle** softkey enables the user to switch between screens of RAM or disk user patterns.

```

  (m)  nP 72643n Error Performance Analyzer      0. 6
  PATTERN
  Ram-based File catalog      1994-03-21 06:12:08
  PATT 1
  Internl  PATT 1
  PATT 1  Curr  USER PAT1      3 000  * 1994-03-21 06:00
  1        USER PAT1      3 000  * 1994-03-21 06:11
  2        2x10 PRBS      1 024  * 1994-03-20 11:25
  Internl  PATT 2
  PATT 2  3        USER PAT2      2 240  * 1994-03-20 11:44
  4        USER PAT3      127  * 1994-03-20 11:48
  Internl  PATT 3
  Internl  PATT 4
  PATT 4  Status
  Pattern select * user-pattern editor
  Pattern alternate Alt: pat once aux I/F toggle
  Length 3 000 Alt: pat once alternnt diskusr
  Label USER PAT1
  Modified no cancel
  edit

```

To enter the editor and gain access to the editor softkeys select an **INTERNAL PATT** or **DISK PATT** store. The contents of the pattern store selected are loaded into the user pattern memory and can now be edited. The **CURRENT PATTERN** softkey enables the user to access the pattern currently loaded in user pattern memory.

## Softkey Menu Descriptions

### Pattern Softkey Menus

DISK	Patt	Label	Length	Alt	LastModified
PATT 5	Curr		1		1994-03-21 03:23
	5		100,000		Not known
DISK 6	6	SONET STS-48	311,040		Not known
DISK 7	7	CID STM-4	20,720		Not known
PATT 8	8	CID STM-16	22,448		Not known
	9	SDH STM-4	77,760		Not known
DISK 10	10	SDH STM-16	311,040		Not known
PATT 11	11	2^7	127		Not known
	12	FDDI Wander	90,000		Not known

DISK Status

Pattern select & user-pattern editor

DISK Pattern PRBS 2^23-1

PATT toggle

cancel

edit

Editor softkeys are as follows:

- INSERT REPLACE** Switches the edit mode between **INSERT** or **REPLACE**. Position the cursor on the point in the pattern to be changed, then use the numeric keypad (1 and 0) keys to insert or replace bits. You can use the **toggle screen** key to allocate a full size window to the pattern.
- PREV SCREEN** If the Pattern length is greater than 576 it is split between two or more screens. Where this is the case the **PREV SCREEN** and **NEXT SCREEN** softkeys enable the user to skip between screens to examine or edit the pattern.
- DELETE BIT** Deletes the bit highlighted by the cursor.
- goto bit** Enables the user to quickly position the cursor on any bit in the pattern.
- save pattern** Enables the user to store the contents of the user pattern memory to a pattern store. The label, pattern type and binary contents of the user pattern memory are all saved.
- toggle screen** Switches the display between allocating a full screen to the pattern editor and the standard display of 2/3 error detector and 1/3 pattern generator.
- load block** Pressing this key produces a sub-menu of softkeys, which enable the user to load a fixed PRBS of 2<sup>7</sup>, 2<sup>10</sup>, 2<sup>11</sup> or 2<sup>13</sup>, or a user pattern into the user pattern memory at the current cursor position. The current setting of the **INSERT REPLACE** softkey controls how the pattern is loaded. See Chapter 8 for more detailed information on **load block**.

## Softkey Menu Descriptions

### Pattern Softkey Menus

- savedel block** Pressing this key produces a sub-menu of softkeys that enable the user to save or delete a block of data; they operate as follows:  
**save** : The user can define a block of bits within the user pattern memory, then save this block to any pattern store large enough to hold the pattern.  
**DELETE** : Use this key to delete a block of bits in the pattern currently in user pattern memory.  
To delete a block of bits: position the cursor at the start of the block, select **savedel** , set the cursor to the end of the block and press **DELETE** .
- SET PAT LENGTH** Enables the pattern length to be selected using the numeric keypad. If the user pattern is active the length chosen must match the appropriate resolution.
- SET PAT LABEL** Enables the user to assign a name or label to a pattern. When the **SET PAT LABEL** softkey is pressed the right-menu changes to give softkeys of **cancel label** , **FINISH ENTRY** , **CLEAR LABEL** and **ENTER CHAR** . To select a pattern label use the display knob to set the cursor on the first letter or digit of the label and press the **ENTER CHAR** softkey. Continue moving the cursor to the next character and pressing **ENTER CHAR** until the label is finished. Press the **FINISH ENTRY** softkey when you have finished entering the label. The **CLEAR LABEL** key erases the label currently being edited. **cancel label** returns the user to the **edit-ramUsr** menu.
- BINARY HEX** This allows the user to toggle the representation of the user pattern data between binary (base 2) and hexadecimal (base 16). This affects only the pattern's representation within the Pattern editor window. The pattern is unaffected. No other display fields within the Pattern editor window are affected.  
In binary mode each complete line within the editor's display shows 32 pattern bits (as 8 fields of 4 bits) and in hex mode 256 pattern bits (as 8 fields of 4 characters at 4 bits per character). In either base the last line of a Pattern editor's pattern display is truncated to show only the minimum number of characters to display the pattern. In hex mode, where the pattern length is not a multiple of 4, the lower bits of the final digit at bit addresses greater than (Length -1) are ignored and considered to be zeros. In hex mode **1** to **9** keys are supplemented by the **A** to **F** softkeys on the Pattern editor's submenu selected via the **hex entry** softkey.



## Softkey Menu Descriptions

### Pattern Softkey Menus

**ALT PAT ON OFF** When **ALT PAT ON** is selected the pattern in the user pattern memory is split into two parts of equal length (up to 4 Mbits), “HALF A” and “HALF B”. When editing an alternating pattern the editor shows the bits of “HALF B” immediately below the corresponding bits of “HALF A”. The pattern “HALF A” lines are displayed with the bit address of the left most bit, i.e. earliest pattern bit transmitted, for both the part of “HALF A” shown and for the corresponding part of “HALF B” displayed on the following line.

Refer to **Alternate test pattern** within Chapter 4 *Operating Features and Specifications* and to the section **Alternate Pattern Control** below for details on alternate pattern lengths and methods of controlling the switching between the two patterns.

Toggling the **ALT PAT** key ON/OFF will set the pattern length to 1.

## disk Utils

### Path

**pattern**, **disk utils**

### Description

A sub-menu comprising two softkeys is displayed when **disk utils** is selected.

**delete diskpat** Permits a disk user pattern to be deleted from a pattern generator disk.

**format disk** Permits a 3.5in. floppy disk to be formatted.

## Alternate Pattern Control

### Path

**pattern** or **MENU**, **pattern**

### Description

This section describes the alternative methods of controlling the switching between “HALF A” and “HALF B” of an alternating user pattern. While the generator will automatically synchronize the changeover to coincide with the transmission of the end of a pattern half, the switching may be initiated from either the softkeys, remotely via HP-IB, or via the AUXILIARY INPUT port.

## Softkey Menu Descriptions

### Pattern Softkey Menus

The controls listed below provide a means of generating predetermined error rates but differing from the Error Add function because the errors are synchronized with the pattern occurring at the same bit addresses in every instance of pattern “HALF B”.

The keys are only enabled when an alternate user pattern is selected. Refer to Alternate Patterns within Chapter 8 *User Patterns and Disk Operation* for a procedure for selecting alternate patterns.

- ALT PAT AUX USR** When **AUX** is selected, the source of control for Alternate Patterns is the AUXILIARY INPUT port. When **USR** is selected, the source of control is from the front-panel or over HP-IB. Refer to Chapter 4 *Operating Features and Specifications* for an explanation of AUX INPUT operation.
- ALT PAT ALT ONCE** This controls how the alternate pattern is output; either each half of the pattern is output alternately (controlled by **ALT PAT HALF AB** softkey) or a single insertion of a number of instances of half B is inserted between repetitions of half A.
- ALT PAT HALF AB** This key is labelled this way only if **ALT PAT ALT ONCE** is set to **ALT**. It selects whether the **A** or **B** half of the pattern is output. It is blank if **ALT PAT AUX USR** is set to **AUX**.
- ALT PAT ONCE B** This key is labelled this way only if **ALT PAT ONCE B** is set to **ONCE**. When pressed it causes the single insertion of a number of instances of half **B** to be inserted between repetitions of half A. The number of half **B** instances is equal to the smallest integral multiple of the pattern length that divides exactly by 128. It is blank if **ALT PAT AUX USR** is set to **AUX**.

## Data Output Menu

### Path

**data output** or **MENU**, **data output**

### Description

The **data output** softkey gives access to a menu of softkeys which enable the following to be set:

- Termination voltage
- Output amplitude
- High output level
- Output ON/OFF switch
- Normal or inverted sense (pattern polarity)
- Clock to data output delay
- External data attenuation
- Data eye vertical cross-over

The attenuator setting allows the user to specify the level referenced to the far (non-pattern generator) side of an external attenuator.

The **data** and **data** Amplitude and High-level may be controlled either together or independently.

The **data output** softkeys are as follows:

**extrnl term** This softkey selects the external termination submenu. Any change of the selected termination causes the Amplitude to be set to minimum. **EXT AC COUPLE** specifies an ac coupled external termination, and disables the High-level control. **EXT DC TERM 0V** specifies a 0V dc coupled external termination and **EXT DC TERM -2V** specifies a -2V dc coupled external termination. The range of High-level available is affected by the 0V or -2V dc termination selected. **exit** returns control to the main Data Output Menu without altering any of the selections.

**DATA AMPLTD** Enables the peak-to-peak amplitude of the data output to be entered in units of volts or millivolts.

**DATA/ AMPLTD** Enables the peak-to-peak amplitude of the **data** output to be entered in units of volts or millivolts.

## Softkey Menu Descriptions

### Data Output Menu

<b>DATA HI-LEVL</b>	Enables the entry of the value for the data high output level in units of volts or millivolts.
<b>DATA/ HI-LEVL</b>	Enables the entry of the value for the $\overline{\text{data}}$ high output level in units of volts or millivolts.
<b>DATA ECL</b>	Sets the data and $\overline{\text{data}}$ outputs to use Emitter Coupled Logic ECL levels. It also resets the Data Amplitude and Data High-level to default values. (Data Amplitude +850 mV; Data High-level -900 mV)
<b>D/TRCK ON OFF</b>	Enables the data and $\overline{\text{data}}$ outputs to operate together (track) or independently.
<b>EXT DAT ATTEN</b>	Enables the user to enter the value of an external data attenuator in decibels and read from the display the data amplitude value at the far end of the attenuator. Changing the value also resets the Data Amplitude and Data High-level to default values (+500 mV and -0V respectively).
<b>DATA ON OFF</b>	Permits the data output signal to be switched off. When off the data output is set to 0V.
<b>DATA/ ON OFF</b>	Permits the $\overline{\text{data}}$ output signal to be switched off. When off the $\overline{\text{data}}$ output is set to 0V.
<b>DAT POL NORMINV</b>	Toggle the data outputs to be either normal or inverted in sense.
<b>DATA DELAY</b>	Enables the entry of a time delay by which the data output should lag the clock output. The delay is entered in picoseconds and may be negative (in which case the data leads the clock). The entry is rounded to the nearest picosecond.
<b>DATA X-OVER</b>	Enables the entry of a value which vertically adjusts the voltage at which the 1 to 0 transitions and the 0 to 1 transitions cross. The $\overline{\text{data}}$ output cross-over adjustment is independent for the data and $\overline{\text{data}}$ outputs and is unaffected by the <b>D/TRCK ON OFF</b> selection. The user value entered specifies a signed deviation of the cross-over from the calibrated 50% setting which is normally used. The range of this control will vary between instruments and may differ between the data and $\overline{\text{data}}$ outputs. While offering repeatability on any given output, the value is uncalibrated and the user entered value should not be read as corresponding with either volts or percentage. This function is provided to allow optimization of the cross-over in critical applications or compensation of non-linearities in the external equipment.

## Softkey Menu Descriptions

### Clock Output Menu

**DATA/ X-OVER** This softkey enables entry of the cross-over control for the  $\overline{\text{data}}$  output. Refer to the description of **DATA X-OVER** above for details.

---

## Clock Output Menu

### Path

**clock output** or **MENU**, **clock output**

### Description

The **clock output** softkey enables a menu of softkeys which permit the level of the clock and inverted clock outputs, and the frequency and amplitude of an external clock source to be set.

<b>EXT AC COUPLE</b>	Sets the clock termination voltage to ac.
<b>EXT DC TERM 0V</b>	Sets the clock termination voltage to 0V. This also causes the Clock High-Level to be reset and modifies the permissible range of the Clock High-Level.
<b>EXT DC TERM -2V</b>	Sets the clock termination voltage to -2V. This also causes the Clock High-Level to be reset and modifies the permissible range of the Clock High-Level.
<b>CLOCK AMPLTD</b>	Enables the peak-to-peak amplitude of the Clock Output to be entered in units of volts or millivolts.
<b>CLOCK/ AMPLTD</b>	Enables the peak-to-peak amplitude of the $\overline{\text{Clock}}$ Output to be entered in units of volts or millivolts.
<b>CLOCK HI-LEVL</b>	Enables the entry of the value for the clock high output level in units of volts or millivolts.
<b>CLOCK/ HI-LEVL</b>	Enables the entry of the value for the $\overline{\text{clock}}$ high output level in units of volts or millivolts.
<b>EXT CLK ATTEN</b>	Enables the user to enter the value of an external attenuator in decibels, and read from the display the clock amplitude at the far end of the attenuator (input to device under test).
<b>CLOCK ECL</b>	Sets the clock outputs to use emitter coupled logic levels. It also resets the Clock Amplitude and Clock High-Level to default values.

## Softkey Menu Descriptions

### Error Add Menu

<b>SIG GEN FREQ</b>	If a slaved clock source or signal generator is connected, this key permits the frequency of this source to be set up. Otherwise, this key is blank.
<b>FREQ STEP</b>	If a slaved clock source or signal generator is connected, this key permits the value of the frequency step to be set up, using the display knob or <b>▲</b> <b>▼</b> keys. Otherwise, this key is blank. Enter the desired frequency step using the large display knob, or the numeric keypad. If you use the keypad the right-menu changes to give softkeys of GHz, MHz, kHz and Hz. Set the step value then select the appropriate softkey. Select the <b>SIG GEN FREQ</b> softkey. Use the <b>▲</b> <b>▼</b> keys on the numeric keypad to increase or decrease the frequency by the step value selected.
<b>SIG GEN AMPLTD</b>	Sets the output amplitude of the signal from an external clock source.
<b>SIG O/P ON OFF</b>	Switches the external clock source output ON or OFF. This key is blank if there is no external clock source.
<b>C/TRCK ON OFF</b>	Enables the clock outputs to operate together (track) or independently.

---

## Error Add Menu

### Path

**error add** or **MENU**, **error add**

### Description

Pressing the **error add** key brings up a second-level menu that permits the control of errors added to the data stream. The **error add** softkeys are as follows:

<b>ERR-ADD SINGLE</b>	Forces a single error in one bit each time the key is pressed. This key also turns off both the fixed error addition and external error addition.
<b>ERR-ADD EXTRNAL</b>	Permits the rising edge of pulses input to the ERROR INJECT INPUT port to add a single error to the data output. Port interface levels are TTL (active low). This key also turns off the fixed error addition.

## Softkey Menu Descriptions

### Subrate Outputs

- ERR-ADD FIXED** Permits errors to be added at a fixed rate. The fixed rate can be varied in powers of ten between the limits of  $1E-3$  and  $1E-9$ .
- ERR-ADD OFF** Use this key to turn ON or OFF the external error addition.

---

## Subrate Outputs

### Path

**subrate outputs** or **MENU**, **subrate outputs**

### Description

The **subrate outputs** softkey gives access to a menu of softkeys which permit the level and termination of the subrate data and clock to be setup.

## Subrate Data Softkeys

- EXT AC COUPLE** Sets the subrate data output termination to ac.
- EXT DC TERM 0V** Sets the subrate data output termination to 0V.
- EXT DC TERM -2V** Sets the subrate data output termination to -2V.
- S/R DAT AMPLTD** Enables the peak-to-peak amplitude of the subrate data output to be entered in units of volts or millivolts.
- S/R DAT HI-LEVEL** Enables the entry of the value for the subrate data high output level in units of volts or millivolts.
- S/R DAT ECL** Sets the subrate data outputs to use emitter coupled logic levels. It also resets the Data Amplitude and Data Hi-Level to default values.(Data Amplitude +500 mV; Data Hi-Level 0V)

## Subrate Clock Softkeys

- EXT AC COUPLE** Sets the subrate clock output termination to ac.
- EXT DC TERM 0V** Sets the subrate clock output termination to 0V.
- EXT DC TERM -2V** Sets the subrate clock output termination to -2V.
- S/R DAT AMPLTD** Enables the peak-to-peak amplitude of the subrate clock output to be entered in units of volts or millivolts.

## Softkey Menu Descriptions

### Trigger & Setup Menu

**S/R DAT HI-LEVL** Enables the entry of the value for the substrate clock high output level in units of volts or millivolts.

**S/R DAT ECL** Sets the substrate clock outputs to use emitter coupled logic levels. It also resets the Clock Amplitude and Clock Hi-Level to default values.(Clock Amplitude +500 mV; Clock Hi-Level 0V)

---

## Trigger & Setup Menu

### Path

**trigger & setup** or **MENU**, **trigger & setup**

### Description

The **trigger & setup** softkey enables a menu of softkeys which allow the user to:

- Configure the pattern generator trigger output
- Configure the error detector trigger output
- Configure the error detector's Error Output pulse type (RZ or stretched)
- Save the entire instrument configuration in one of ten USER SETUPS.
- Recall an entire instrument configuration from one of ten USER SETUPS or two PRESETS.

## Pattern Generator Trigger Output

The Pattern Generator Trigger Output produces a 16 clock-period trigger pulse (except alternate word) which is either synchronized to the pattern (PATTERN mode) or is the input clock divided by 32 or 8. In PATTERN mode the trigger pattern that the user has entered is matched to the pattern being generated and a trigger pulse is produced when the two correspond. For a  $2^n-1$  pattern the length of the trigger pattern is n bits, which ensures that the pattern will be unique. The pulse repetition rate is 1 pulse/32 pattern repetitions.

When a zero-substitution PRBS, a mark-density PRBS or a user-defined pattern is selected, then the trigger pattern is selectable with the **PG TRIG BIT** softkey. It can be set anywhere within the pattern. Trigger pulse occurs at lowest common multiple of 256 and pattern length.

When an alternate pattern is selected, the user can select between a trigger pulse synchronized to the signal at the AUXILIARY INPUT or one pulse per pattern.

**PG TRIG PAT CLK** Toggles between *PATTERN* mode, in which the occurrence of a user-entered pattern in the output stream, is the condition which



## Softkey Menu Descriptions

### Trigger & Setup Menu

causes a trigger pulse to be output; and CLOCK mode, in which the Trigger Output is the input clock divided by 8 or 32.

- PG TRIG /8 /32** Select a clock/8 or clock/32 pattern generator trigger.
- PG TRIG PATTERN** This key is enabled when the Pattern selected is a *pure* PRBS of  $2^{31}-1$ ,  $2^{23}-1$ ,  $2^{15}-1$ ,  $2^{10}-1$ , or  $2^7-1$ . Enables entry of a bit pattern of length 7, 10, 15, 23 or 31 bits for triggering depending on the current setting of the *pure* PRBS. An all-ones pattern is disallowed.
- PG TRIG BIT** This key is enabled when the Pattern selected is an User Pattern, Zerosub or Markden pattern. It enables the position of the trigger bit to be varied. This is an active parameter. If a user-defined pattern is selected, this key controls the trigger bit position of the pattern currently in the edit buffer. It does not affect the trigger bit position of the stored patterns. If the current pattern is saved, the trigger bit is saved with the pattern contents.
- PG TRIG A-B PAT** This key is enabled whenever an alternate user-defined pattern is selected. Either the **A-B** or the **PAT** is underlined. If the **A-B** is selected, then the trigger pulse occurs synchronously as alternate pattern halves are selected. If **PAT** is selected, then the trigger pulse is synchronized to the first bit of the pattern.

## Error Detector Trigger Output

Pattern and clock triggers are provided. The clock trigger is a square wave at the clock rate divided by 32. The pattern trigger for a pure PRBS is 1 pulse/32 pattern repetitions. For all other patterns the trigger pulse occurs at the lowest common multiple of 256 and the pattern length.

- ED TRIG PAT CLK** Use this key to select the error detector pattern trigger output mode. Toggles between PATTERN mode in which the trigger pulse is synchronized to repetitions of the output pattern, and clock MODE in which the trigger pulse is a square wave at the clock rate divided by 32.

## Error Detector Errors Output

- ERR O/P RZ200ns** Permits the length of the pulse at the error detector ERRORS OUTPUT port to be switched between RZ or stretched 200 ns.

## Save and Recall Instrument Setup

Each SETUP comprises an entire pattern generator and error detector configuration. Although the instrument configures itself at power-on exactly as it was prior to being switched off, setups provide a convenient method for switching between diverse configurations each of which would otherwise involve many separate configuration changes.

- |                     |   |
|---------------------|---|
| <b>recall setup</b> | Enables a lower-level menu from which either one of ten <i>USER SETUPS</i> or two predefined <i>PRESETS</i> is selected for configuration.<br>See Chapter 9 for a list of <i>PRESET</i> configurations. |
| <b>save setup</b>   | Enables the submenu allowing the user to specify which of the ten <i>USER SETUPS</i> the entire system configuration is to be stored.   |

---

## Misc Menu

### Path

**MENU** **misc**

### Description

The **misc** softkey allows miscellaneous user functions to be selected. The **misc** right menu softkeys are as follows:

- |                    |   |
|--------------------|---|
| <b>KEYBRD LOCK</b> | Toggles between the locked and unlocked state. When locked the user can not modify any of the instrument's configuration parameters, only display parameters. Keyboard is locked when the softkey is underlined.  |
| <b>set clock</b>   | Enables softkeys which allow the user to set up the error detector real-time clock. This is the clock that is used to time stamp logging. On power-up, the error detector searches the HP-MSIB address space to its left (both on the same row and below) for a module with TIME capability. If it finds one and reads a valid time from it, the error detector deems that module to be the holder of the system time and will not let the user set the time in the error detector. The error detector will re-sync its time to the system time at power-on and every hour (when not gating). If the error detector does not find another module with the time, |

## Softkey Menu Descriptions

### Misc Menu

it uses the time from its real-time clock as the system time. In this case the user can set the date and time as they wish.

---

**NOTE**

---

The above algorithm specifically uses the HP-MSIB address and not the HP-IB address.

The range of the date and time is from the start of 1990 to the end of 2049.

When the user is setting the time the individual parameters (hours, minutes and seconds) are not coupled in any way and have the expected ranges.

When setting the date, there is a degree of coupling involved. If the user selects a YEAR which causes the current DAY setting to be invalid, the day is changed by the minimum amount to make it valid, for example, 29 Feb 91 is changed to 28 Feb 91. Similarly, if the user selects a MONTH which makes a day invalid, the DAY is again changed. When entering a DAY, only those days which are valid for the current month and year settings are allowed.

**update frmware**

Shows the firmware version codes, in the form A.nn.nn. Within the instrument there are 4 separate firmware components;

- Control processor application code contains all the Pattern Generator and Error Detector configuration control and some of the Detector's measurement functions.
- Measurement processor application code contains the remainder of the Error Detector's measurement functions.
- Control processor boot code comprises functions performed during the power-on sequence in order to verify basic hardware operation of the control processor.
- Measurement processor boot code comprises functions performed during the power-on sequence in order to verify basic hardware operation of the measurement processor.

Hewlett-Packard may issue further revisions of either application code module and these are installed via the instrument's 3.5in. disk drive by selecting **update frmware** followed by **UpdCntlAppl** or **UpdMeasAppl**, as appropriate.

Refer to **How to Update the HP 70843 Firmware**, page 1-13. The firmware version for any MMS signal generator slaved to the error performance analyzer is displayed in the **Miscellaneous** configuration window below the instrument's

## Softkey Menu Descriptions

### Result Pages Menu

firmware versions. Should the MMS signal generator require a firmware update then the procedure will be described in the operating manual for the signal generator.

#### **SELF TEST**

Enables the instrument to self-test the processor ROM and RAM. Instrument settings are not affected by this self-test.

---

## Result Pages Menu

### Path

**result pages** or **MENU**, **result pages**

### Description

There are six menus displaying instrument status and results that are available to the user. The **result pages** key enables the user to view and select one of these menus. Also on the **result pages** menu are **build usr-pge** and **CLEAR USR-PGE** softkeys which enable the user to generate/edit a user-definable page of results or status lines.

The following figures are examples of the six result menus:

## Main Results Display

The following figure illustrates the **Main Results**.

```
HP 70043A Error Performance Analyzer (0, 0)
MAIN RESULTS Main results 1994-03-21 05:43:00
OTHER Pattern PRBS 2^23-1
RESULTS Bit count 19,999,956,640
Error count 200,000
Error ratio 1.000e-05
INTERVL Delta error count 0
RESULTS Delta error ratio 0.000e+00
Errors
G.021 Gating elapsed 0 d 0 h 0 m 20 s (100x)
RESULTS Sync loss seconds 0
Err Det clock freq 100000 GHz
EYE Pat Gen clock freq 999.98 MHz
RESULTS Pattern select & user-pattern editor
Pattern PRBS 2^23-1
USER'S PAGE
```

## Softkey Menu Descriptions

### Result Pages Menu

### Other Results Display

The following figure illustrates **Other Results**.

```
HP 70043A Error Performance Analyzer (0, 8)
MAIN RESULTS
Other results 1994-03-21 05:46:50
OTHER RESULTS Pattern user, length 127
RESULTS 0 -> 1: Error count 10,218
1 -> 0: Error count 2,382
INTERV 0 -> 1: Error ratio 0.188e-07
RESULTS 1 -> 0: Error ratio 1.892e-07
G.021 BIT: Error address capture error 0
RESULTS BIT: Error count 0
BIT: Error ratio 0.000e+00
EYE BIT: Delta error count 0
RESULTS BIT: Delta error ratio 0.000e+00
Pattern select & user-pattern editor
Pattern user
Length 127
Label USER PAT3
USER'S Modified no
PAGE
```

### Intervl Results

The following figure illustrates **Intervl Results**.

```
HP 70043A Error Performance Analyzer (0, 8)
MAIN RESULTS
Interval results 1994-03-21 05:48:48
OTHER RESULTS Pattern user, length 127
RESULTS Error secs 5
Error decisecs 36
Error centisecs 315
INTERV Error millisecs 3,113
RESULTS Error free secs 21
G.021 Error free decisecs 224
RESULTS Error free centisecs 2,285
Error free millisecs 22,887
EYE Power loss seconds 0
RESULTS Error Detector gating control
Gating repeat mode manual
Burst gating off
USER'S PAGE
```

## Softkey Menu Descriptions

### Result Pages Menu

### G.821 Results

The following figure illustrates **G.821 Results**.

```
HP 70043A Error Performance Analyzer (0, 0)
MAIN RESULTS      G.821 results      1994-03-21 05:50:18
                  Pattern          user, length  127
OTHER RESULTS
RESULTS  Availability      28.000 x
          Unavailability  72.000 x
INTERVL  Severely Errored Secs  0.000 x
RESULTS  Errored Secs        14.285 x
          Degraded Minutes  0.000 x
G.821
RESULTS
EYE
RESULTS
          Error Detector gating control
          Gating repeat mode  manual
          Burst gating       off
USER'S
PAGE
```

### Eye Results

The following figure illustrates **Eye Results**.

```
HP 70043A Error Performance Analyzer (0, 0)
MAIN RESULTS      Data eye results      1994-03-21 05:53:48
                  Pattern          user, length  127
OTHER RESULTS
RESULTS  Eye width          930.0 ps (93.0% of cycle)
          Eye height       302.0 mV
INTERVL  Eye center (time)    81.00 ps
RESULTS  Eye center (voltage)   -244.0 mV
G.821
RESULTS  Center eye threshold  1.000e-03
          Center clock freq  1.0000 GHz
          Center delta err ratio  0.000e+00
EYE
RESULTS  Status              0/1 data input threshold centered
          Error Detector input and eye control
          0/1 threshold mode  manual
          0/1 manual-mode threshold level -244.0 mV
          Data polarity      normal Delay 81 ps
          Data term          0 V Clock term 0 V
USER'S
PAGE  Eye edge threshold ratio  1.000e-03
```

### User's Page

The contents of the user's page are configured by the user. Refer to the Build User-Page menu on the following page.

---

## Build User-Page Menu

### Path

**result pages**, **USER'S PAGE** **build usr-pge**

### Description

Use the **build usr-pge** softkey and its associated menus of softkeys to generate or edit your own (USER'S) display of results or status items. This key also makes the **USER'S PAGE** the current page selection.

These keys are all toggle-type keys; when not underlined, pressing one adds the appropriate line (or lines) into the **USER'S PAGE** in the first (starting at the top of the page) available line (or lines). If there is no space available for the line, an error is reported. If a softkey label is underlined, pressing the key will remove the appropriate line (or lines) from the display. The **CLEAR USR-PGE** softkey deletes all user-page selections from the screen.

The **build usr-pge** softkeys are as follows:

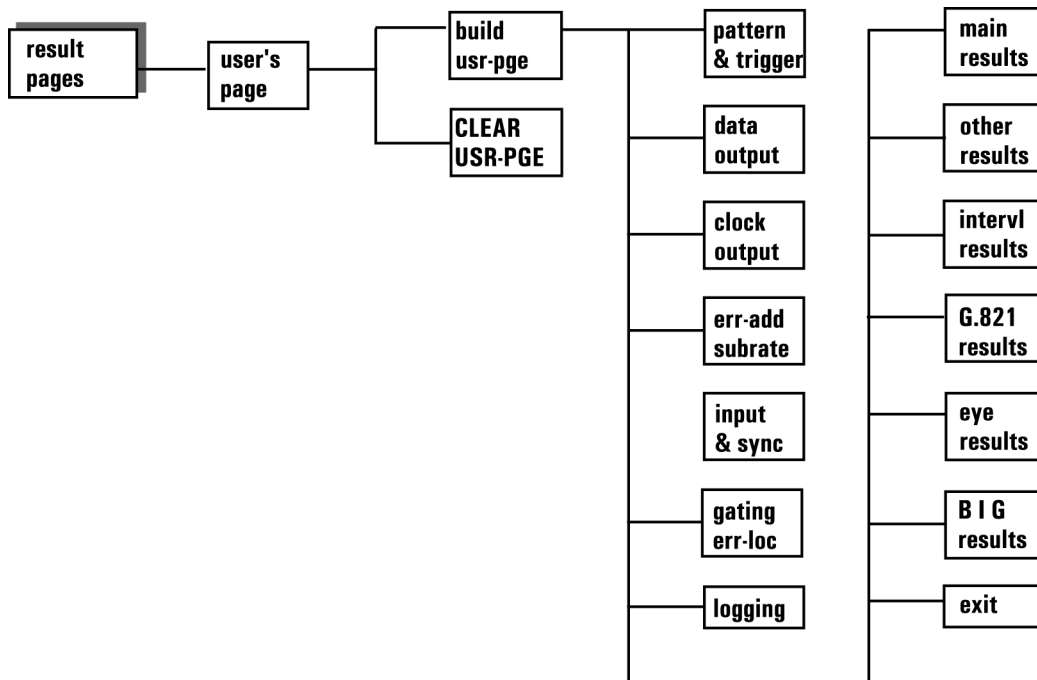

Each of the softkeys shown above has a subordinate menu of softkeys enabling results or status lines to be added to the display. These keys are listed and an explanation given for each key in the following pages.

**Softkey Menu Descriptions**  
**Build User-Page Menu**

**Pattern & Trigger USER'S PAGE menu**

<b>pattern</b>	Displays the pattern currently selected.
<b>PG TRIG MODE</b>	Displays the selected pattern generator trigger mode (clock/8, clock/32 or pattern).
<b>PG TRIGGER</b>	Displays the current trigger bit pattern. For a pure PRBS the trigger bit pattern length is 7, 10, 15, 23 or 31 depending on the setting of the pure PRBS. For a user pattern, zerosub or markden pattern the position of the trigger bit is displayed.
<b>ED TRIG MODE</b>	Displays the selected error detector trigger mode (clock/32 or pattern).
<b>ED ERR OUTPUT</b>	Displays the format of error output pulses (RZ or stretched).

**Data & Clock Output USER'S PAGE menus**

<b>CLK O/P AMPLTD</b>	Displays the main clock output amplitude.
<b>CLK O/P HI-LEVL</b>	Displays the main clock output Hi-level.
<b>CLK O/P TERM</b>	Displays the main clock output termination (0V or -2V).
<b>DAT O/P AMPLTD</b>	Displays the main data output amplitude
<b>DAT O/P HI-LEVL</b>	Displays the main data output Hi-level value.
<b>DAT O/P TERM</b>	Displays the main data output termination.
<b>DAT O/P CONTROL</b>	Displays the main data output CONTROL (ON or OFF).
<b>DAT O/P POLRITY</b>	Displays the main data output polarity (normal or inverted).
<b>DAT O/P DELAY</b>	Displays the clock to data output delay.
<b>DATA/ TRACK</b>	Displays the "tracking" configuration state which determines whether the Amplitude and High-level controls for $\overline{\text{data}}$ follow those of the data output or are independent.
<b>DATA X-OVER</b>	Displays the cross-over settings for data and $\overline{\text{data}}$ .

**Err-add Subrate USER'S PAGE menu**

<b>S/R DAT AMPLTD</b>	Displays the subrate date amplitude.
<b>S/R DAT HI-LEVL</b>	Displays the subrate data Hi-level value.
<b>S/R DAT TERM</b>	Displays the subrate data termination selection (0V or -2V).
<b>S/R CLK AMPLTD</b>	Displays the subrate clock amplitude.



**Softkey Menu Descriptions**  
**Build User-Page Menu**

<b>S/R CLK HI-LEVEL</b>	Displays the substrate clock Hi-level value.
<b>S/R CLK TERM</b>	Displays the substrate clock termination selection (0V or -2V).
<b>ERROR ADD</b>	Displays the current error add mode selection (SINGLE, EXTERNAL FIXED or OFF).

**Input & Sync USER'S PAGE menu**

<b>0/1 THRESHLD</b>	Displays the selected 0/1 threshold setting (AUTO or MAN).
<b>DAT I/P POLRITY</b>	Displays the selected data input polarity (normal or inverted).
<b>DAT I/P DELAY</b>	Displays the clock to data input delay.
<b>DAT I/P TERM</b>	Displays the data input termination (0V or -2V).
<b>CLK I/P TERM</b>	Displays the clock input termination (0V or -2V).
<b>EYE THRESHLD</b>	Displays the eye edge threshold value.
<b>SYNC MODE</b>	Displays the selected sync mode (AUTO or MANUAL).
<b>SYNC THRESHLD</b>	Displays the selected sync threshold.
<b>AUDIO SYNCLS</b>	Indicates whether AUDIO SYNCLS is ON or OFF.

**Gating Err-loc USER'S PAGE menu**

<b>GATING RPT MOD</b>	Displays selected gating mode (MANUAL, SINGLE or REPEAT).
<b>GATING DUR MOD</b>	Displays selected gating duration (TIME, ERRS or BITS).
<b>GATING PERIOD</b>	Displays selected gating period.
<b>GATING REPORT</b>	Displays results from the PREVIOUS or CURRENT gating interval.
<b>BLOCK START</b>	Displays the block start address for Block BER measurements.
<b>BLOCK LENGTH</b>	Displays block length selected for Block BER measurement.
<b>BIT ERR ADDRESS</b>	Displays the bit error address for error location measurements.

**Logging USER'S PAGE menu**

<b>LOGGING DEVICE</b>	Indicates whether the instrument is set to log to an external controller or an HP-IB printer.
<b>LOGGING STATUS</b>	Indicates whether LOGGING is ON or OFF.

## Softkey Menu Descriptions

### Build User-Page Menu

<b>LOG ALARMS</b>	Indicates whether the LOG ALARMS softkey is enabled or disabled.
<b>LOG PRD FULLUSR</b>	Displays either a Full Report or the User's Page results selections at the end of the measurement period.
<b>SQUELCH STATUS</b>	Indicates whether Squelch is ON or OFF.
<b>TRIGGER THRSHLD</b>	Displays the current selection of the user-threshold that is used to determine when output is logged.
<b>TRIGGER 1 SEC</b>	Displays the trigger which, when it occurs will initiate logging during the gating period. The selection is between log on error seconds and log on the error ratio greater than a set threshold.
<b>TRIGGER END PRD</b>	Displays the trigger which will initiate logging at the end of the gating period. The selection is between always, error count non-zero and error ratio greater than a set threshold.

### Main results USER'S PAGE menu

<b>ELAPSED GATING</b>	Displays the time that has elapsed in the current gating period in either normal or extra large characters.
<b>SYNC LOSS s</b>	Displays the number of one second intervals (since the start of the gating period) for which the incoming and internal patterns were out of synchronization.
<b>ED CLK FREQ</b>	Displays the frequency of the clock signal at the error detector CLOCK IN port.
<b>PG CLK FREQ</b>	Displays the frequency of the clock signal at the pattern generator CLOCK IN port.
<b>BIT COUNT</b>	<p>The bit count is the accumulated count of clock bits since the start of gating. Its value will normally be the running sum, but will differ when:</p> <ul style="list-style-type: none"><li>Input gating has been applied, Block BER has been used to window part of the pattern.</li><li>When a sync search has occurred with any mark density, zero substitution or user pattern.</li></ul> <p>The bit count can be controlled by input signals to the error detector front panel GATING INPUT. A TTL level low signal at the GATING INPUT stops the error counters.</p>

## Softkey Menu Descriptions

### Build User-Page Menu

**ERROR COUNT** Displays the error count accumulated since the start of the gating period, displayed in either normal or extra large characters. Extra large characters are selected using the **BIG results** softkey.

---

**NOTE** When extra large characters are selected, the selection takes up four lines of display.

---

**ERROR RATIO** Displays the ratio of the number of errors to the number of clock pulses, since the start of the gating period, displayed in either normal or extra large characters.

**DELTA COUNT** Displays the error count accumulated in the last decisecond, displayed in either normal or extra large characters. This display is updated even when not currently gating.

**DELTA RATIO** Displays the ratio of the number of errors to the number of clock pulses in the last decisecond, displayed in either normal or extra large characters. This display is updated even when not currently gating.

**ERRORS** Enables a bar graph which provides a graphical representation of delta error count.

**exit** Returns to the main USER'S page menu.

### Other results USER'S PAGE menu

**ERR CNT 0 → 1** Displays the number of data *zeros* detected in error as a data *one* accumulated since the start of the gating period.

**ERR CNT 1 → 0** Displays the number of data *ones* detected in error as data *zeros* since the start of the gating period.

**ERR RAT 0 → 1** Displays the number of data *zeros* detected in error as a data *one* divided by the number of clock periods since the start of the gating period.

**ERR RAT 1 → 0** Displays the number of data *ones* detected in error as a data *zero* divided by the number of clock periods since the start of the gating period.

The following five results are only valid when option UHJ is fitted.

**BIT ERR ADDRESS** Displays the location (address) of the bit at which error location measurements are performed.

## Softkey Menu Descriptions

### Build User-Page Menu

<b>BIT ERR CNT</b>	Displays the error count accumulated since the start of the gating period at the BIT ERR ADDRESS selected by the user.
<b>BIT ERR RAT</b>	Displays the ratio of the number of errors to the number of clock periods at the BIT ERR ADDRESS selected by the user.
<b>DELTA BIT CNT</b>	Displays the error count accumulated in the last decisecond at the BIT ERR ADDRESS selected by the user.
<b>DELTA BIT RAT</b>	Displays the ratio of the number of errors to the number of clock pulses in the last decisecond at the BIT ERR ADDRESS selected by the user. This display is updated even when not currently gating.
<b>exit</b>	Returns to the main USER'S PAGE menu.

### Interval results USER'S page menu

<b>ERROR SECS</b>	Displays the number of one second intervals (since the start of the gating period) in which one or more errors were detected.
<b>ERROR DECI S</b>	Displays the number of one decisecond intervals (since the start of the gating period) in which one or more errors were detected.
<b>ERROR CENTI S</b>	Displays the number of one centisecond intervals (since the start of the gating period) in which one or more errors were detected.
<b>ERROR MILLI S</b>	Displays the number of one millisecond intervals (since the start of the gating period) in which one or more errors were detected.
<b>POWER LOSS S</b>	Displays the number of one second intervals (since the start of the gating period) for which power to the error detector was lost.
<b>ERR FRE SECS</b>	Displays the number of one second intervals (since the start of the gating period) in which no errors were detected.
<b>ERR FRE DECI S</b>	Displays the number of one decisecond intervals (since the start of the gating period) in which no errors were detected.
<b>ERR FRE CENTI S</b>	Displays the number of one centisecond intervals (since the start of the gating period) in which no errors were detected.
<b>ERR FRE MILL S</b>	Displays the number of one millisecond intervals (since the start of the gating period) in which no errors were detected.
<b>exit</b>	Returns the user to the USER'S PAGE menu.

**Softkey Menu Descriptions**  
**Build User-Page Menu**

**G.821 results USER'S PAGE menu**

<b>AVAILBL (%)</b>	Displays G.821 Availability measurement.
<b>UNAVAIL (%)</b>	Displays G.821 Unavailability measurement.
<b>SEV ERR SECS (%)</b>	Displays G.821 Severely Errored Seconds measurement.
<b>ERRORED SECS (%)</b>	Displays G.821 Errored Seconds measurement.
<b>DEGRAD MINS (%)</b>	Displays G.821 Degraded Minutes measurement.
<b>exit</b>	Returns the user to the USER'S PAGE menu.

**Eye results USER'S PAGE menu**

<b>EYE THRSILD</b>	Displays the eye width measured during the last successful occurrence of the clock-to-data alignment, and the eye edge threshold value set when it was measured.
<b>EYE HEIGHT</b>	Displays the last measured value of the data input eye height.
<b>TIME CENTER</b>	Displays the time at the center of the data input eye.
<b>VOLTAGE CENTER</b>	Displays the last measured value of the voltage at the center of the data input eye.
<b>CENTER THRSILD</b>	Displays the 0/1 threshold value at the center of the data input eye.
<b>CENTER FREQ</b>	Displays the frequency at the center of the data input eye.
<b>CENTER DEL RAT</b>	Displays the delta error ratio at the center of the data input eye.
<b>EYE STATUS</b>	Gives a progress report on clock-data alignment.
<b>exit</b>	Returns the user to the USER'S PAGE menu.

---

**NOTE** When extra large characters are selected, the selection takes up four lines of display.

---

**BIG results USER'S PAGE menu**

<b>BIG ERR CNT</b>	Displays Error Count in extra large characters.
<b>BIG ERR RAT</b>	Displays Error Ratio in extra large characters.
<b>BIG DELTA C</b>	Displays Delta Error count in extra large characters.
<b>BIG DELTA R</b>	Displays Delta Error ratio in extra large characters.
<b>BIG ELAPSED</b>	Displays Elapsed Gating in extra large characters.
<b>exit</b>	Returns the user to the USER'S PAGE menu.

## Input & Eye Menu

### Path

**input & eye** or **MENU**, **input & eye**

### Description

The **input & eye** key gives access to a menu of softkeys which enable the setting up of the error detector Data Input and Clock Input electrical characteristics, including the level at which the transition between a mark and a space is recognized (the 0/1 threshold level). The *active* clock edge is the direction of clock transition relative to which the data input is sampled.

The **input & eye** softkeys are as follows:

**0/1 THR AUTOMAN** Toggles the selection of the zero-to-one threshold level between manual and automatic.

**0/1 MAN THRSHLD** Allows entry of the level at which the zero-to-one discrimination will be performed, can be set in units of volts or millivolts.

#### To Select 0/1 Threshold Manual Mode

Select **input & eye**, set **0/1 THR AUTOMAN** to **MAN** then press the **0/1 MAN THRSHLD** softkey, (the key will be displayed in inverse video). Use the RPG Display knob or the Numeric Keypad to enter the desired 0/1 Threshold. The value selected is displayed in the *Error Detector Input and eye control* window on the display.

#### To Select Automatic Tracking

Select **input & eye** then set **0/1 THR AUTOMAN** softkey to **AUTO**, (**AUTO** is underlined when selected). If for example the pattern generator Data Amplitude were set to 500 mV and the Data High Level to 0.0 V, the Automatic 0/1 Threshold Mode value displayed will be approximately –250 mV.

**DAT POL NORMINV** Toggles the polarity of the input data pattern

**DAT I/P DELAY** Sets the time delay from the *active* clock edge to the time at which the data is actually sampled. The value is entered in picoseconds and may be negative, in which case the data is sampled before the nominated clock edge. The entry is rounded to the nearest picosecond.

## Softkey Menu Descriptions

### Input & Eye Menu

- DAT TRM 0V -2V** Toggles the data input termination level between ground and -2 V.
- CLK TRM 0V -2V** Toggles the clock input termination between ground and -2 V.
- CLK-DAT ALIGN** Initiates an attempt to align the data input delay so that the Error Detector samples in the center of the data input eye. While alignment is in progress the right-menu changes to give an **ABORT ALIGN** softkey. The user may press this key at any time and the alignment will abort and return the instrument to its original state.

#### To Perform Clock-to-Data Alignment

Select **result pages**, **EYE RESULTS** to view eye results. Now select **input & eye**, then press the **CLK-DAT ALIGN** softkey. The eye width is displayed in the Data eye results window.

- 0/1 THR CENTER** Initiates an attempt to set the zero-to-one threshold to the mid-point of the incoming data eye on the vertical, voltage axis.

#### To Select Automatic Center

In this mode it is recommended to first set the “EYE EDGE THRESHOLD” to a known BER (bit error ratio) threshold, perform a clock-to-data alignment and then select Automatic Center mode.

#### To Perform Automatic Center

Select **input & eye**, then press the **0/1 THR CENTER** softkey. The *eye height* is displayed, and the 0/1 manual-mode threshold level given plus other data eye results.

- EYE EDG THRSHL D** Sets the threshold used by the clock/data align feature in the search for the edges of the data eye. The range of valid values is  $1.0E-1$  through  $1.0E-7$ .

For example to enter a BER threshold of  $1.5E-02$ : Press the **EYE EDG THRSHL D** softkey. Enter 1.5 using the numeric keypad, then press the **e** right-menu softkey. Finish entering the number (2) using the numeric keypad then press **ENTER**.

The Eye Edge Threshold is used by the clock-to-data align and 0/1 threshold center functions to define the edges of the data input eye.

## Sync & Audio Menu

### Path

**sync & audio** or **MENU sync & audio**

### Description

The **sync & audio** key gives access to a menu of softkeys that control how the error detector searches for synchronization (that is, tries to align the incoming pattern with the internal pattern that the user has selected). The patterns are deemed to be synchronized when the measured error rate is less than the set sync threshold: a user-defined value. Also included are softkeys to control an audible warning that sounds when bit errors or sync loss occur.

The **sync & audio** softkeys are as follows:

<b>SYNC AUTOMAN</b>	Toggles between the error detector automatically initiating re-synchronization whenever synchronization is lost (AUTOMATIC), and requiring the user to initiate re-synchronization by hand (MANUAL).
<b>START SYNC</b>	Forces the error detector to initiate a re-synchronization.
<b>1e-1 to 1e-8</b>	Allows the selection of a synchronization threshold 1E-01 through 1E-08 in decade steps.  When a sync-start is initiated, the message <i>Trying to gain sync</i> is displayed on the prompt line. If, after trying all possible reference pattern alignments, sync is still not gained then the message <i>Sync attempt failed, retrying</i> is displayed. Note selecting a sync threshold of too high a level can cause mis-synchronization.
<b>AUDIO ON OFF</b>	Toggles on or off an audible warning that bit errors have occurred. The audible output varies with error rate. The effect of changing error rate is: <ul style="list-style-type: none"><li>• Isolated errors - output produces a 100 ms tone.</li><li>• Other error rates - 5% change in error rate produces an audible change.</li></ul>
<b>AUDIO VOLUME</b>	The audible output can be set to one of 15 volume levels by selecting this key then using the RPG knob on the HP 70004A display.
<b>AUDIO SYNC LS</b>	When this key is underlined (ON) an audible warning will sound if sync loss occurs



## Gating Menu

### Path

**gating** or **MENU**, **gating**

### Description

The **gating** softkey gives access to a menu of softkeys which control the error detector measurement (gating) period. The three gating modes (MANUAL, SINGLE and REPEAT) are a one-of-three selection.

### Gating after a Power Loss

After a power loss the error detector will attempt to regain sync for approximately 25 seconds.

- If sync is regained within 25 seconds gating will restart immediately.
- If after 25 seconds has elapsed sync has not been regained, gating is forced to start.

The Power Loss Seconds result displayed is the overall time that gating was lost, and thus the time that the system was unable to make a measurement.

---

**NOTE** Neither the gating mode, nor the gating period may be changed while gating is active.

---

The **gating** softkeys are as follows:

**RUN GATING** Starts the error detector gating, or stops the current gating action and begins a new gating period.

**STOP GATING** Stops the current gating action.

*The next three keys are mutually exclusive:*

**MANUAL** Configures the error detector to make measurements over a gating period controlled by the user.

**SINGLE** Configures the error detector to make measurements over one gating period and then stop.

**REPEAT** Configures the error detector to make repetitive measurements whereby one gating period follows another immediately. There is no *deadtime* between the end of one period and the start of the next.

## Softkey Menu Descriptions

### Gating Menu

<b>GATE BY TIME</b>	Configures the error detector to perform SINGLE and REPETITIVE gating periods that are controlled by elapsed time. The available units are days, hours, minutes or seconds. The input value must not exceed the maximum period of 99 days, nor be less than 1 second. When the selected time has accumulated, the gating period ends. This key is blank whenever MANUAL gating is selected.
<b>GATE BY ERRS</b>	Configures the error detector to perform SINGLE and REPETITIVE gating periods that are controlled by the accumulation of bit errors. The range of bit errors over which gating can occur is 10, 100 and 1000. When the selected number of bit errors have been accumulated, the gating period ends. This key is blank whenever MANUAL gating is selected.
<b>GATE BY BITS</b>	Configures the error detector to perform SINGLE and REPETITIVE gating periods that are controlled by the accumulation of clock bits. The choice of number of bits over which gating occurs is 1E7 through 1E15 in decade steps. When the selected number of clock periods have been accumulated, the gating period ends. This key is blank whenever MANUAL gating is selected.
<b>GATING PERIOD</b>	<p>The user may elect to gate <b>BY TIME</b>, <b>BY ERRORS</b>, or <b>BY BITS</b>, selectable using the appropriate softkey.</p> <p>Note: if MANUAL gating is selected only gating <b>BY TIME</b> is available.</p>
<b>BURST GATING</b>	<p>Burst gating is only enabled when a MANUAL gating mode, and a PRBS pattern of <math>2^{31}-1</math>, <math>2^{23}-1</math>, <math>2^{15}-1</math>, <math>2^{10}-1</math> or <math>2^7-1</math> is selected. In Burst gating mode gating the Error Detector's bit and error counters are only enabled while the GATING INPUT is high.</p> <p>Refer to the <b>Burst Gating</b> section in Chapter 4 for a detailed description of this operating mode and its application.</p>
<b>REPORT PREVCUR</b>	Configures the error detector to display the results from the previous complete gating period or the results currently being accumulated. This selection is effective in REPEAT mode only.

## Error Location

### Path

**error locat'n** or **MENU**, **error locat'n**

### Description

Error location enables the user to define a specific bit in a RAM-based pattern and then make measurements at that location. The specific bit is known as the BER location and can be specified by the user. Error location has three forms as follows:

- Bit BER
- Error location capture
- Block BER

The **error locat'n** softkeys are as follows:

**BIT ERR ADDRESS** Use this key in conjunction with the numeric keypad to specify the BER location.

**CAPTURE ERROR** Pressing this key instructs the instrument to search for an error. If it finds an error it reads the errors location to the BER location and initiates gating. The instrument may or may not be gating when the measurement is initiated. In either case gating starts/restarts after the new BER location is received. After an error is located the instrument displays:

**BIT: Error Address** **nnn**  
**Data window** **xxxx xxxx xxxx xxxx xxxx xxxx xxxxy xxxx**  
• **xxx...** - pattern around error, 28 bits before error and 3 bits after error are displayed.  
• **y** - errored bit in inverse video

An error is only captured once for each measurement - each time CAPTURE ERROR is pressed.

**BLOCK BER** Pressing this key selects a Block BER measurement and enables the **BLOCK START** and **BLOCK LENGTH** keys which set the parameters for a Block BER measurement. Block BER measures the BER of a range of bits in the pattern. It replaces normal BER measurements. Blocks of bits must be a multiple of 32 bits, with the block specified by a start location.

**BLOCK START** Use this key to select the start location for the block of bits.

**BLOCK LENGTH** Use this key to set the length of the block of bits. The length must be a multiple of 32 bits with the start location specified.

## Logging Menu

### Path

**MENU** logging

### Description

The **logging** softkey enables a menu of softkeys which allow error detector data logging functions to be set up.

---

**NOTE** The keys marked with an \* cannot be changed when logging.

---

The **logging** softkeys are as follows:

- |                         |  |
|-------------------------|--|
| <b>LOG TO HPIB</b>      | This key configures the HP 71612 to become an HP-IB controller and so allows it to log output to an HP-IB printer. The address of the printer must be 1. There must not be any external HP-IB controller connected when this key is selected.  |
| <b>LOG TO EXT CTL</b>   | This key configures the HP 71612 to log output to an external HP-IB controller. The HP 71612 will SRQ when it has a line of text to output. The controller can then ask for this line of text with the LTEXT? command.   |
| <b>LOGGING OFF ON</b>   | Switches logging OFF or ON. When OFF, the logging is totally suppressed.   |
| <b>LOG ALARMS*</b>      | Logs the time that the following alarms start and end:<br>Clock Loss, Data Loss and Sync Loss.<br>Power Loss and Power Recovery are always logged regardless of whether the LOG ALARMS key is enabled or not.  |
| <b>LOG PRD FULLUSR*</b> | Provides the user with the choice of selecting from two sets of results at the end of the measurement period, they are: <ul style="list-style-type: none"><li>• FULL: Logs Main Results, Interval Results and G.821 Analysis</li><li>• USR: Logs the results currently part of the Users Page (except Delta Error results)</li></ul>   |
| <b>SQUELCH OFF ON</b>   | When SQUELCH is ON, logging is inhibited if logging is triggered for ten consecutive seconds, thus preventing excessive use of paper. The trigger for logging may be an error second or the error ratio exceeding a preset threshold. Squelch can be overridden by the LOG ON DEMAND key. Squelch does not effect end of period logging. Logging is resumed after one trigger free second. |

## Softkey Menu Descriptions

### Logging Menu

**LOG ON DEMAND** Logs a single snapshot of the current results at the instant the key is pressed, irrespective of whether the system is gating or not, and whether logging is enabled or disabled. Current results are time stamped with the date and time at which the results were valid. The output logged is dependent on the current state of the instrument, and is defined as follows:

- LOGGING ON, Gating ON: results only logged
- LOGGING OFF, Gating ON: header and results logged
- LOGGING ON or OFF, Gating OFF: header and results logged

**TRIGGER THRESHLD\*** Enables the user to select a trigger threshold in the range 1.0 to 1.0E-20 using the numeric keypad. The trigger threshold is compared against one second error ratio values to determine when results are logged.

For example, to enter a threshold of 1.50E-02 press the **LOGGING THRESHLD** key, enter 1.50 using the numeric keypad, then press the **e** right-menu softkey. Finish entering the number (02) using the numeric keypad then press **ENTER** .

**trigger 1 sec\*** Enables the following sub-menu of softkeys:

**LOG ON ERR SEC** Logs events during gating when an errored second occurs. The set of results logged when an errored second occurs is *Error Count* and *Error Ratio* for the second before the trigger occurred.

**LOG ON RAT>THR\*** Logs events during gating, when the error ratio for the last second exceeds a user defined threshold. The threshold is in the range 1.0 to 1.0E-20 inclusive. Error count and error ratio for the last second are logged.

**trigger end prd** Enables the following sub-menu of softkeys:

**LOG END ALWAYS** Sets the instrument to *Always* log results at the end of a measurement period. Cannot be changed during logging. The contents of the output are controlled by the **LOG PRD FULLUSR** key. If **LOG PRD FULL** is selected the instrument logs main results plus interval results plus G.281 Analysis. If **LOG PRD USR** is selected the results currently part of the USER'S page are logged.

**LOG END ERRS>0\*** Sets the instrument to log results at the end of the measurement period if the Error Count >0. Cannot be changed during logging. The contents of the output are controlled by the **LOG PRD FULLUSR** key.

## Softkey Menu Descriptions

### Logging Menu

**LOG END RAT>THR\*** Set the instrument to log results at the end of the measurement period when the Error Ratio exceeds a preset threshold. Cannot be changed during logging. The contents of the output are controlled by the **LOG PRD FULLUSR** key.

---

**User Patterns and Disk  
Operation**

---

## Define, Edit and Store User Defined Patterns

### Introduction

The HP 71612 Series error performance analyzers and pattern generators offer the user the ability to define and store their own patterns (user patterns) in up to twelve pattern stores. The contents of the pattern stores can be recalled and edited as necessary. The following paragraphs give a description of pattern editor operation, including a list of editor features, and procedures for editing patterns. Refer to Chapter 7 for a description of editor softkeys.

### Basic Editor Operation

There are three main functional blocks which together provide the capability to edit, store, and output a programmable user pattern. These are the editor, pattern stores, and the user pattern memory from which the instrument outputs a user pattern. The relationship between these three functional blocks is shown in Figure 8-1.

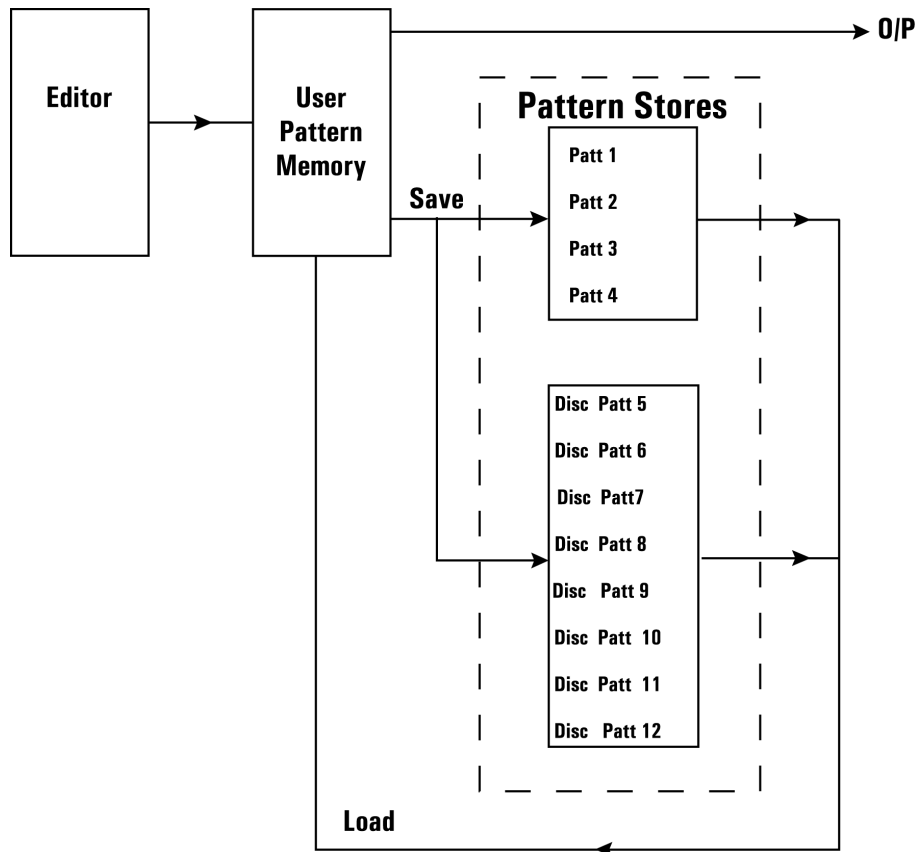

Figure 8-1 The Editor



## User Patterns and Disk Operation

### Define, Edit and Store User Defined Patterns

## The Editor

The editor always edits the contents of the user pattern memory. Thus if you wish to edit one of the twelve pattern stores, you must first load the pattern store into the user pattern memory, edit the pattern, then save the pattern back to the pattern store.

## Editor Features

You can use the pattern editor to perform the following:

- Load into user pattern memory and edit/output one of four internal pattern stores or one of eight disk pattern stores.
- Load and edit one of four fixed PRBS patterns of  $2^7$ ,  $2^{10}$ ,  $2^{11}$  and  $2^{13}$ .
- Copy the contents of one user pattern into another user pattern.
- Select between binary and hexadecimal displays.
- Save the contents of the user pattern memory (current pattern) to one of the four internal pattern stores or eight disk patterns.
- Load the contents of a pattern store to a precise point in the user pattern memory, highlighted by the display cursor.
- Define a block of bits within the user pattern memory and save to a pattern store large enough to hold the block.
- Delete a block of bits within the user pattern memory.
- Alter display size to allow simultaneous display of results information while editing.

## Pattern Stores

There are twelve pattern stores as follows:

- Pattern Stores 1 to 4 can hold patterns up to 8 kbits in size. The data is held in non-volatile RAM.
- Patterns 5 to 12 are held on disk and can accommodate patterns of up to 8 Mbits in length, subject to a disk with sufficient free space being available. These patterns are held in separate files on the disk.

## Current Pattern

The **CURRENT PATTERN** softkey enables the user to access the pattern currently stored in user pattern memory. This is the pattern that is output, when the user selects a User Pattern as the active output pattern.

**User Patterns and Disk Operation**  
**Define, Edit and Store User Defined Patterns**

**Choosing a Pattern**

On the occasions when a user has to choose a pattern store, a display similar to that in the following figure is shown. Two pattern catalog screens are used as follows:

Patterns 1 - 4 plus the CURRENT PATTERN are displayed in a RAM-based file catalog.

Patterns 5 - 12 plus the CURRENT PATTERN are displayed in a disk-based file catalog. The **toggle** menu key allows switching between these file catalogs.

**RAM-Based File Catalog**

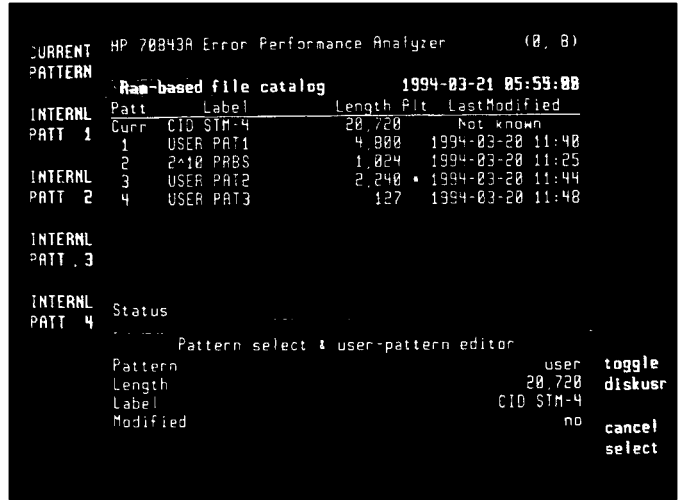

**Disk-Based File Catalog**

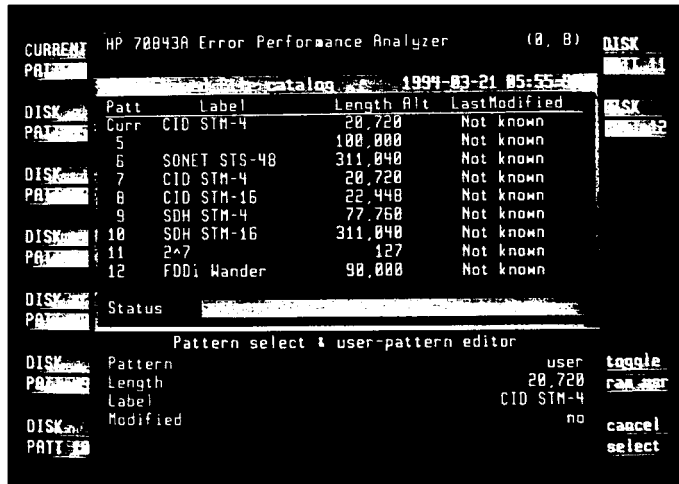

---

**NOTE** Loading and saving large user patterns from or to a disk can take several minutes.

---

## User Patterns and Disk Operation

### Define, Edit and Store User Defined Patterns

The information shown for patterns 5 to 12 directly reflects the state of the currently accessible disk. The user makes a choice by pressing the appropriate softkey.

If the user changes the disk inserted in the drive, the display contents are regenerated to reflect the contents of the new disk.

If the disk is not accessible, the lines for pattern stores 5 to 12 are replaced with a single text message **no disk present**, and the DISK PATT menu keys are **greyed** out. If the instrument is unable to access a pattern store, an error message indicating the problem is displayed beside that store's entry.

### User Pattern Memory

This is the 8 Mbit memory from which the instrument transmits any user pattern. The contents of a pattern store can be copied into the user pattern memory and edited, or the contents of the user pattern memory saved to a pattern store. The editor always edits the contents of this memory.

When no disk is accessible, the user pattern memory is the only memory capable of holding a pattern longer than 8 kbits. If the instrument is powered down its contents are replaced with the contents of the pattern store last selected.

### Exiting the Editor By Mistake

If you have just exited the editor by mistake, by perhaps pressing one of the hardkeys on the keyboard and wish to ensure that the pattern you were editing is not lost use the following short procedure.

If your HP 70004A display does not have an instrument hardkey panel, then in the following procedure select **MENU** first then the keys given. The *pattern* key will be a softkey and not a hardkey as listed.

#### Procedure

Select **pattern**, **edit ram usr**, **CURRENT PATT** then **save pattern**. Now select the pattern store softkey in which you wish to save the edited pattern (**INTERNAL PATT** or **DISK PATT**).

## How to Set Up and Edit Your Own User Pattern

### Introduction

The HP 71612 Series error performance analyzer and pattern generator offer the user the ability to define twelve user patterns. Any one of these patterns may be recalled and edited, for example:

- During a measurement when a pattern other than a user pattern is being output.
- During a measurement when the pattern to be edited is the active pattern (the pattern currently being output).

---

### NOTE

If you select a user pattern ensure that the sync threshold is compatible with the pattern being generated. Failure to set the correct sync threshold may result in incorrect synchronization. Incorrect synchronization results in errors and may cause clock-to-data alignment failure.

---

## To Edit User Patterns

### Procedure

1. Press the **pattern** key on the display keyboard, then select **edit ram usr** or **edit diskusr**.
2. Select a pattern store **INTERNAL PATT** or **DISK PATT**.
3. For this example let's edit **INTERNAL PATT1**.
4. Select **INTERNAL PATT1**.
5. The display now changes to show the current pattern in user pattern 1, and also gives a set of softkeys to enable you to edit and view the pattern. The contents of internal pattern 1 are now loaded into the *user pattern memory*, and you are now able to edit then save the contents of pattern 1 either back to **INTERNAL PATT1** or any other pattern store. Use the **toggle screen** softkey to allocate a full screen to the Pattern editor.

## User Patterns and Disk Operation

### How to Set Up and Edit Your Own User Pattern

6. The following figure gives an example of a pattern loaded from **INTERNAL PATT1**.

```

INSERT  nr 70000 Error Performance Analyzer          0 0      load
REPLACE                                     block
Pattern editor          1994-03-21 05:50:40
PREV   USER PATT1      User Patt: 1      REPLACE ACTION savedet
SCREEN (00000000) 0111 1111 1111 1000 0000 0100 0100 0001 block
(00000001) 1000 0110 1011 0110 1010 1000 0010 0001
(00000002) 1101 1011 1000 1000 0100 0010 1111 0111
NEXT   (00000003) 1111 1110 1100 0000 1100 1010 0101 1101 SET PAT
SCREEN (00000004) 0100 1110 1100 1010 0100 1101 0100 0011 LENGTH
(00000005) 0100 1111 0101 1010 1111 0100 1011 1111
DELETE (00000006) 1001 1110 0010 1101 1000 1110 0001 0000 SET PAT
BIT    (00000007) 0001 1101 1000 1000 1001 0010 1010 0000 LABEL
(00000008) 0100 0111 0011 0100 0001 1101 1110 1000
(00000009) 1011 1111 1011 1110 0011 0110 1000 0100
goto   (00000010) 0011 1111 0111 0010 0110 1001 0001 1011 ALTPATT
BIT    (00000011) 0001 0010 0010 0100 0010 1000 0111 1101 ON OFF
(00000012) 1110 0101 1011 1010 1100 0101 1010 1001
save   (00000013) 1100 1001 0100 0100 0010 1101 0111 1110 BIN HEX
pattern (00000014) 0101 1100 1010 1110 0101 0011 0010 1010
(00000015) 1111 0100 0011 1111 1111 0010 0000 0101
toggle
screen Cursor:      0 Trig:      0 Length:  4 500

```

---

**NOTE** The following steps explain how to perform individual edit functions. There is no need to complete the whole procedure; refer to each explanation as required. It is assumed that the user is currently working in the editor.

---

#### Set Pattern Length

1. Press the **SET PAT LENGTH** softkey - enter the pattern length using the numeric keypad and press the **ENTER** softkey.

#### Insert/Replace Bits in the Pattern

1. Press the **INSERT/REPLACE** softkey to select the function required. The key label underlined is the one selected.  
It may be that the part of the pattern in which you wish to insert or replace bits is not currently displayed. To view the part of the pattern containing the bits of interest you can use the **NEXT SCREEN**, **PREV SCREEN** or **goto bit** softkeys. For fast access to a bit in a large pattern use the goto bit softkey. Set the cursor address (at bottom of screen) to the number of the bit to be edited, then press **ENTER**. Use the numeric keypad 1 and 0 keys to insert or replace bits in the pattern.

#### Delete Bits

1. Use the display knob or **goto bit** softkey to set the cursor to the bit number of the bit to be deleted, then press **DELETE BIT**.

## User Patterns and Disk Operation

### How to Set Up and Edit Your Own User Pattern

#### To Save a Pattern

When you have finished editing a pattern it must then be saved to a pattern store. This can be to a disk store or one of the four internal pattern stores. Use the following procedure to save an edited pattern to any pattern store.

#### Procedure

1. Press the **save pattern** softkey. The display will change to show the RAM-based file catalog. Use the **toggle** softkey to switch between each file catalog display, an example is shown in the following figure.

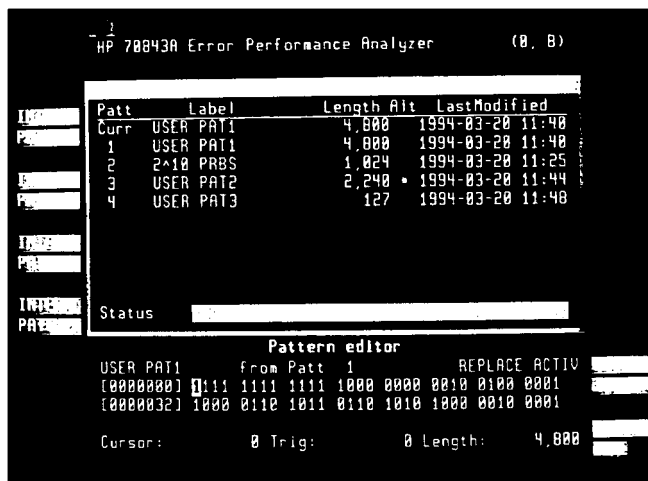

2. Select the softkey indicating the pattern store into which you wish to store the edited pattern.

#### To Load a Pattern Store Into the Editor

The following procedure explains how to load the contents of a pattern store (INTERNAL or DISK) into the editor when the user is not currently working in the editor.

#### Procedure

Use this procedure if you are not currently working in the editor.

1. Select the **pattern** hardkey.
2. Press **edit ram usr** or **edit diskusr** then select an **INTERNAL PATT 1 to 4** or **DISK PATT 5 to 12**.

The pattern store selected is now displayed and you can edit that pattern using the softkeys. The following two procedures explain how to load a PRBS or user pattern into the editor.

**User Patterns and Disk Operation**  
**How to Set Up and Edit Your Own User Pattern**

## **To Load a PRBS or User Pattern into the Editor**

The editor load block function enables the user to load one of four fixed PRBSs, or the contents of a user pattern store into the *user pattern memory* at the current cursor position. The current setting of the **INSERT/REPLACE** softkey determines whether the contents of the PRBS or pattern store (the block) are inserted into, or replace bits in the pattern.

The number of block bits loaded from the PRBS or pattern store is tailored to fit between the cursor and pattern end. For example if the cursor is sitting on bit 500 of a 900 bit pattern, then when a block load is performed up to 400 bits can be inserted/replaced. If you wish to load a pattern larger than the defined pattern length, then you must increase the length accordingly.

## **To Load a Block of Data (PRBS)**

The following procedure explains how to load a fixed PRBS into the editor.

### **Procedure**

1. Select **pattern**, **edit ram usr**.
2. Select the pattern store into which you wish to load a block of data. (for example **INTERNAL PATT 4**).
3. Set the cursor to the bit in the pattern where you wish to insert/replace a block of data. Use the display knob or **goto bit** softkey.
4. Set the **INSERT/REPLACE** softkey to the desired mode.
5. Select **load block** - the menu changes to give a sub-menu set of softkeys, offering the choice of selecting a fixed PRBS of **2<sup>7</sup>**, **2<sup>10</sup>**, **2<sup>11</sup>** or **2<sup>13</sup>**, or a **ram Usr pattern** or **diskUsr pattern**. For this procedure, select a PRBS.
6. When you select a PRBS the right-menu changes to give softkeys of **set zerosub**, **NO MODIFY**, **zero sub**, **mark density** and **cancel load**.  
If you do not wish to edit zero substitution or mark density, press **NO MODIFY** then proceed to step 9.

### **To Edit Zero Substitution**

7. Press the **set zerosub** softkey. Enter the value of the longest run of zeros using the numeric keypad (see bottom of screen), and then press **ENTER**. Now press **zero sub**.

### **To Edit Mark Density**

8. Press the **MARK DENSITY** softkey. The right-menu changes to offer softkeys of **1/8**, **1/4**, **1/2**, **3/4**, **7/8** and **cancel load**, select from the choices given or press **cancel load**.

## User Patterns and Disk Operation

### How to Set Up and Edit Your Own User Pattern

9. When you press **NO MODIFY** or finish editing zero sub or mark density the display returns to the main editing screen, with the PRBS pattern selected loaded into the editor (user pattern memory) starting from the current cursor position. The cursor is positioned after the last inserted bit (or at end of pattern) after the command is complete.
10. To save the edited pattern, press **save pattern** then select a pattern store softkey.

### To Load a User Pattern Into the Editor

The following procedure explains how to load the contents of a user pattern store into the user pattern memory, at the current cursor position.

#### Procedure

1. Repeat steps 1 to 4 of the previous procedure (loading a PRBS).
2. Select **load block** - the menu changes to give a sub-menu set of softkeys, offering the choice of selecting a fixed PRBS of **2<sup>7</sup>**, **2<sup>10</sup>**, **2<sup>11</sup>** or **2<sup>13</sup>**, or a **ram** or **diskUsr pattern**.
3. Select the **ram Usr pattern** or **diskUsr pattern** softkey and proceed to step 4.

#### Load Copies of User Patterns

When you select the **ram Usr pattern** or **diskUsr pattern** softkeys you are offered the choice of loading more than one copy of the pattern. The number of copies you make is however limited by the length of the current pattern in the user pattern memory.

4. If you wish more than one copy press **#COPIES TO LOAD**, enter the number using the display numeric keypad, then press **ENTER**.
5. Select the **INTERNAL PATT** or **DISK PATT** store whose data you wish to load into the user pattern memory.  
The contents (block) of the pattern store you have just selected are now loaded into the editor at the point highlighted by the cursor.
6. You can now elect to save the contents of the user pattern memory to a pattern store, or edit further and then save to a pattern store. To save the block (pattern) you have loaded, press **save pattern**, then select a pattern store **INTERNAL PATT** or **DISK PATT**.



**User Patterns and Disk Operation**  
**How to Set Up and Edit Your Own User Pattern**

**To Save a Block of Data**

The user can define a block of bits within the current user pattern memory, then save the block to any pattern store large enough to hold the pattern. The current pattern store contents are overwritten by the new data being saved. The label of the pattern store is changed to that of the user pattern memory.

**Procedure**

The following procedure explains how to define a block of bits within a pattern in the user pattern memory, and then save the block to a user pattern store.

1. Select **pattern** , **edit ram usr** .
2. Call-in to the editor the pattern store containing the block of data you wish to save/delete (select an **INTERNAL PATT** or **DISK PATT** store), or select a pattern store and create your own pattern.
3. Set the cursor on the first bit of the block of data to be saved or deleted, use the **goto bit** softkey or display knob. The following figure gives an example of a pattern loaded from pattern store 1, and with the cursor on bit 3490.

```

INSERT  HP 70043R Error Performance Analyzer          (0, 0)  load
REPLACE                                     block

                                Pattern editor          1994-03-21 06:02:08

PREV    USER PAT1      from Patt 1      REPLACE ACTIU savedel
SCREEN  [0003488] 0000 1100 1001 1101 1100 0100 1010 0001  block
        [0003520] 0001 0111 1101 0111 1101 1101 1101 1010
        [0003552] 1010 1000 1000 0001 1010 1100 1010 1010
NEXT    [0003584] 1101 0000 0010 0111 1001 1001 0110 1111  SET PAT
SCREEN  [0003616] 1011 0001 1011 0010 0010 0011 0010 1010  LENGTH
        [0003648] 0111 0100 0101 0011 1101 1010 1011 1000
        [0003680] 1000 1100 0010 1001 1011 1101 0110 0111  SET PAT
DELETE  [0003712] 1101 0111 0101 1101 1011 0110 1000 0000  LABEL
BIT     [0003744] 0011 1100 0001 0011 0010 1100 1111 0110
        [0003776] 1110 1110 0001 0101 0001 1110 0011 0001  ALTPATT
        [0003808] 1000 0110 0011 0110 1100 0100 0000 1001  ON OFF
        [0003840] 0110 0110 0011 0111 1100 0100 1101 0001
        [0003872] 0011 0111 0100 1100 1011 1011 1101 1101
        [0003904] 0111 1010 1101 1111 1010 0011 0011 1110  BIN HEX
        [0003936] 0111 1010 1011 0111 1000 1000 1110 0010
        [0003968] 1000 0000 1101 1100 0101 0010 0001 1010

toggle  Cursor: 3,490 Trig: 0 Length: 4,000
screen

```

4. Select **savedel block** .
5. Set the cursor on the last bit of the block of data to be saved or deleted. The block of data will be shown underlined. The following figure gives an example of a pattern where a block of bits from 3490 to 4000 is selected.

## User Patterns and Disk Operation

### How to Set Up and Edit Your Own User Pattern

6. Press **save to ram**, then select the **INTERNAL PATT** or **DISK PATT** store into which you wish to store the block of data.

```

PREV      HP 70043A Error Performance Analyzer      (0, 6)
SCREEN
          Pattern editor      1994-03-21 06:03:00
          USER PAT1 from Patt 1 REPLACE ACTIU
NEXT      [0003520] 0001 0111 1101 0111 1101 1101 1101 1010
SCREEN    [0003552] 1010 1000 1000 0001 1010 1100 1010 1010
          [0003584] 1101 0000 0010 0111 1001 1001 0110 1111
gotn      [0003616] 1011 0001 1011 0010 0010 0011 0010 1010
bit       [0003648] 0111 0100 0101 0011 1101 1010 1011 1000
          [0003680] 1000 1100 0010 1001 1011 1101 0110 0111
          [0003712] 1101 0111 0101 1101 1011 0110 1000 0000
save      [0003744] 0011 1100 0001 0011 0010 1100 1111 0110
to ram    [0003776] 1110 1110 0001 0101 0001 1110 0011 0001
          [0003808] 1000 0110 0011 0110 1100 0100 0000 1001
save      [0003840] 0110 0110 0011 0111 1100 0100 1101 0001
to disk   [0003872] 0011 0111 0100 1100 1011 1011 1101 1101
          [0003904] 0111 1010 1101 1111 1010 0011 0011 1110
DELETE    [0003936] 0111 1010 1011 0111 1000 1000 1110 0010
BLOCK     [0003968] 1000 0000 1101 1100 0101 0010 0001 1010
          [0004000] 0011 1010 1110 0001 1011 0001 1010 0010

Cursor:   4,000 Trig:      0 Length:   4,000 cancel
                                                block
  
```

7. The block of data assigned in step 5 is now stored in the pattern store selected in step 6, and overwrites the data previously stored there.

### To Delete a Block of Data

The user can define a block of bits within the current user pattern memory (CURRENT PATTERN), and then delete that block.

#### Procedure

1. Perform steps 1 to 5 of the previous (block save) procedure, then select the **DELETE BLOCK** softkey. The bits shown underlined will be deleted.

### Alternate Patterns

Use the following procedures to set the instrument to output two patterns A and B, and switch between patterns, or insert instances of pattern B into pattern A. The source of control for alternate patterns can be one of the following:

- From the instrument front panel.
- The AUXILIARY INPUT port.
- Over HP-IB.

Only the front panel and AUXILIARY INPUT mode of control is explained here. Refer to Chapter 4 *Operating Features and Specifications* for detailed specifications on alternate patterns.

## **To Select Alternate Pattern Control**

### **Procedure**

This procedure assumes that one of the RAM or disk user patterns is an alternate pattern. If there is not an alternate pattern, refer first to the procedure on how to generate an alternate pattern.

1. Select the following softkeys in the order given:  
**pattern** , **ram Usr pattern** - select an alternate user pattern from the **INTERNAL PATT** or **DISK PATT** list.
2. Set the **ALT PAT AUX USR** softkey to **USR** for front panel control, or **AUX** for control via the front panel AUX INPUT.
3. Set the **ALT PAT ALT ONCE** softkey to the mode you require. An explanation of the function of this key is given in Chapter 7.

## **To Generate an Alternate Pattern**

The following procedure explains how to generate an alternate pattern with an  $2^{10}$  PRBS loaded into pattern A (half A) and pattern B (half B). The maximum length of each is 4 Mbits.

### **Procedure**

1. Select the **pattern** key.
2. Select the **edit ram usr** or **edit diskUsr** key.
3. Select an **INTERNAL PATT** or **DISK PATT** store.
4. Set the **ALTPATT ON OFF** softkey to **ON** , then select **YES** .

---

### **NOTE**

When you switch the key from OFF to ON or ON to OFF the pattern that is currently in the user pattern memory is erased and a 0 is loaded into memory.

---

## User Patterns and Disk Operation

### How to Set Up and Edit Your Own User Pattern

The following figures give an example of the contents of the user pattern memory before and after **ALTPATT** is set to **ON**.

```

INSERT HP 70043A Error Performance Analyzer (0, 0) load
REPLACE Pattern editor 1994-03-21 06:05:40 block
PREV USER PAT1 from Patt 1 REPLACE ACTIV saved
SCREEN [0000000] 0111 1111 1111 1000 0000 0010 0100 0001 block
[0000032] 1000 0110 1011 0110 1010 1000 0010 0001
[0000064] 1101 1011 1000 1000 0100 0010 1111 0111
NEXT [0000096] 1111 1110 1100 0000 1100 1010 0101 1101 SET PAT
SCREEN [0000128] 0100 1110 1100 1010 0100 1101 0100 0011 LENGTH
[0000160] 0100 1111 0101 1010 1111 0100 1011 1111
DELETE [0000192] 1001 1110 0010 1101 1000 1110 0001 0000 SET PAT
BIT [0000224] 0001 1101 1000 1000 1001 0010 1010 0000 LABEL
[0000256] 0100 0111 0011 0100 0001 1101 1110 1000
goto [0000288] 1011 1111 1011 1110 0011 0110 1000 0100 ALTPATT
bit [0000320] 0011 1111 0111 0010 0110 1001 0001 1011 ON OFF
[0000352] 0001 0010 0010 0100 0010 1000 0111 1101
[0000384] 1110 0101 1011 1010 1100 0101 1010 1001
save [0000416] 1100 1000 0100 0100 0010 1101 0111 1110
pattern [0000448] 0101 1100 1010 1110 0101 0011 0010 1010
[0000480] 1111 0100 0011 1111 1111 0010 0000 0101
toggle Cursor: 0 Trig: 0 Length: 4,000
screen

```

**ALTPAT set to OFF**

```

INSERT HP 70043A Error Performance Analyzer (0, 0) load
REPLACE Pattern editor 1994-03-21 06:06:20 block
PREV USER PAT1 from Patt 1 MODIFIED REPLACE ACTIV saved
SCREEN [0000000] 0 block
NEXT [0000032] 0 SET PAT
SCREEN LENGTH
DELETE [0000064] 0 SET PAT
BIT LABEL
goto [0000096] 0 ALTPATT
bit [0000128] 0 ON OFF
[0000160] 0
[0000192] 0
[0000224] 0
[0000256] 0
[0000288] 0
[0000320] 0
[0000352] 0
[0000384] 0
[0000416] 0
[0000448] 0
[0000480] 0
toggle Cursor: 0 Trig: A-B CHNG Length: 1
screen

```

**ALTPAT set to ON**

5. Select the **SET PAT LENGTH** softkey, and set the correct pattern length. You must ensure that you select a pattern length that is at least as large as the pattern to be loaded into the user pattern memory. For this example select a length of 3000 bits using the numeric keypad then press **ENTER**.
6. Position the cursor at the point in the pattern where you wish the block of data loaded (in this case a 2<sup>10</sup> PRBS) - use the **goto bit** softkey. For this example set it to 0.

## User Patterns and Disk Operation

### How to Set Up and Edit Your Own User Pattern

7. Select the **load block** softkey, then select a **2<sup>10</sup> PRBS** . You may edit the PRBS zero substitution, or mark density or press **NO MODIFY** . When you exit this menu the 2<sup>10</sup> PRBS is loaded into the A half of the alternate pattern, as shown in the following figure.

```

INSERT HP 70843A Error Performance Analyzer (0, 8) load
REPLACE Syncls block
Pattern editor 1994-03-21 05:08:28
PREV USER PAT1 from Patt 1 MODIFIED REPLACE ACTIV savedel
SCREEN [0000000] 0111 1111 1100 0000 0111 0000 1111 1101 block
          0000 0000 0000 0000 0000 0000 0000 0000
NEXT [0000032] 1100 0100 1111 1000 1100 1111 1010 1100 SET PAT
SCREEN [0000064] 1011 0010 0100 1000 0000 0001 0000 0010 LENGTH
          0000 0000 0000 0000 0000 0000 0000 0000
DELETE [0000096] 0100 0100 0001 1001 0011 0100 0010 0101 SET PAT
BIT [0000128] 0000 0000 0000 0000 0000 0000 0000 0000 LABEL
          0100 0011 1101 0111 0101 1011 0110 0000
goto [0000160] 0001 1000 0011 0110 0110 0001 0101 1010 ALTPATT
bit [0000192] 0000 0000 0000 0000 0000 0000 0000 0000 ON OFF
          0000 0000 0000 0000 0000 0000 0000 0000
          [0000224] 0110 0011 0111 1110 0010 0011 1100 1111 BIN HEX
          0000 0000 0000 0000 0000 0000 0000 0000
toggle Cursor: 0 Trig: A-B CHNG Length: 3.000
screen

```

#### To Load a 2<sup>10</sup> PRBS into Half B of the Alternate Pattern

8. Use the display **▼** key to position the cursor on half B of the alternate word.
9. Position the cursor at the point in pattern B where you wish to load a 2<sup>10</sup> PRBS. Use the **goto bit** softkey - for this example select bit 0.
10. Select the **load block** softkey then select a **2<sup>10</sup> PRBS** .
11. Press **NO MODIFY** or edit further using the **set zerosub**, **mark density** softkeys. The 2<sup>10</sup> PRBS is now loaded into the B half of the alternate pattern. You can use the **PREV SCREEN** softkey to view the patterns loaded.

#### To Save the Alternate Pattern

12. Press the **save pattern** softkey. Select a pattern store in which to store the alternate pattern ( **INTERNAL PATT** or **DISK PATT** ).
13. Select the **pattern** hardkey then **ram User** or **disk User pattern** and view the pattern list to check your pattern is saved correctly.

## Disk Operation

### Introduction

The following provides information on the operation of the disk drive used in an HP 71612 error performance analyzer for the storage of user patterns.

### Running out of Disk Space

When the contents of the user pattern memory is being stored to disk, there may not be enough room on the disk to hold the new pattern. When this occurs a message is displayed at the bottom of the display. To remedy this situation the user must make more disk space available, and resave his pattern while the pattern remains in the user pattern memory.

The two options available, either to insert a disk with more space, or to delete one of the other disk-based pattern stores to release more space on the same disk, are described in detail below:

#### An example of the first option is:

1. If there is a formatted, initialized disk available, insert it, and skip to step 4.
2. Enter the `pattern` top-level function menu.
3. Insert a disk in the drive, then select `disk utils`, `format disk`  
`FORMAT YES`.
4. Re-enter the editor as follows: select `pattern`, `edit ram usr` and  
`CURRENT PATTERN`.
5. Select `save pattern` then save to the original pattern store.

#### and the second option:

1. Enter the `pattern` top-level function menu and select `disk utils`.
2. Select the `delete diskpat` softkey, and choose one of the disk-based patterns from the pattern selection window which is no longer required. The pattern selected is deleted from the disk, and its disk space is available for other patterns.
3. Re-enter the editor as follows: select `pattern`, `edit ram usr` and  
`CURRENT PATTERN`.
4. Select `save pattern` the save to a pattern store.

## Unable to Write to Disk

A similar problem to running out of disk space is that of being unable to write to the disk inserted in the drive. Possible reasons for this problem are:

1. There is no disk in the drive to write to.
2. The write-protect tab on the disk is set to prevent writing.
3. There is a hardware fault.

When a write operation fails within the editor, a simple error message is shown at the bottom of the screen and the user remains in the editor, with the pattern intact.

## Disk Organization

Although DOS supports a hierarchical directory structure, the instrument only looks for pattern files in the topmost root directory.

The patterns are stored, one per file, in the root directory. A similar file is also present to store the data in the buffer used during **block save** and **block load**. The pattern files are named in some consistent manner, for example:

HPPATTO1.DAT - HPPATTO8.DAT.

On DOS there are no system-defined file types, but the files are tagged with one of the conventional suffixes, **DAT**, to indicate a data file.

The format of information held in a pattern or the buffer file is shown in Table 8-1. It should be noted that all integers are held in unsigned representation. The file containing the buffer data has a fixed label **Buffer**, and a pattern index of 0.

**User Patterns and Disk Operation**  
**Disk Operation**

**Table 8-1**                      **Internal Format of Pattern/Buffer file**

<b>Offset</b>	<b>Type</b>	<b>Description</b>
0	unsigned int	revision code
4	unsigned int	1= pattern file good - RESERVED
8	unsigned int	always 0 - RESERVED
12	unsigned int	always 0 - RESERVED
16	unsigned int	Header string length (=16)
20	string (max 20 chars)	Header string (=HP Pattern Store)
40	unsigned int	pattern index (depends on store ID)
44	unsigned int	pattern type. 0= single pattern. 1= alt pattern
48	unsigned int	pattern length
52	unsigned int	pattern label string length
56	string (max 14 chars)	pattern label string
70	unsigned int	trigger bit (alt patt =0)
74	unsigned int	trigger type (single patt=0), when alt patt, 0= A,B change, and 1= start of pattern
78	pattern data	contents of pattern

The format of the three basic types of data stored on disk are detailed in Tables 8-2, 8-3 and 8-4. Each field is described in detail in the following paragraphs.

### **Header String Length**

This unsigned integer contains the number of characters in the header string.



## Header String

A fixed string which must be present in a pattern file for that file to be considered valid. The suggested string is “HP Pattern Store”.

**Table 8-2** Disk Format of Unsigned Integer

---

Offset	Description
0	first byte of integer (most significant)
1	second byte of integer
2	third byte of integer
3	fourth byte of integer (least significant)

**Table 8-3** Disk Format of String

---

Offset	Description
0	first 8-bit character of string
...	
string length - 1	last 8-bit character of string

**Table 8-4** Pattern Data Format

---

Offset	Description
0	first byte of pattern data (most sig. bit first bit of pattern)
...	
roundup (pattern length/8)-1	last byte of pattern (lower (patt_size MOD 8) bits zero)

## Revision Code

An unsigned integer specifying which format is used to record the pattern information in the file. This document specifies the first such format, revision 1, but this field allows future changes to be indicated. It is reasonable to expect a given firmware release to read all formats which pre-date it, but not those that post-date it.

## Pattern Index

Matches the pattern number minus 4. The pattern in pattern store 9 is stored in file PATTO5 and has an index of 1 in the pattern number field. Provides a further confidence check that the file is really the pattern file.

## Pattern Label String Length

The label given to the pattern store by the user. The label may contain any eight bit code. The characters represented by given codes are specified by the display. It is recommended that only ASCII character codes are used.

## Pattern Length

For a straight pattern, this field holds the length of the pattern in bits. The minimum allowable length is 1. For an alternate pattern, this field holds the length of a pattern, and not the cumulative length of both patterns. Note: both patterns must have the same length. See Table 4-1 (on page 4-4) for allowable pattern lengths.

## Trigger Bit

The position of the trigger bit within the pattern. The position must be greater than, or equal to 0, and less than the pattern length.

## Type of Pattern

This integer encodes the type of pattern held in the file. At present two types of pattern are defined:

- **Type 0** - straight pattern
- **Type 1** - alternate pattern

## Pattern Contents

There are two cases to consider, storage of straight patterns and alternate patterns. For straight patterns, the most significant bit of the first byte contains the first bit of the pattern. When the pattern length is not an exact multiple of 8, the lesser significant bits of the last byte are set to zero. The size in bytes of the pattern contents field is the value:

$(\text{pattern length} \div 8)$  rounded up to the nearest integer

For alternate patterns, the two patterns are each stored in a format identical to that used for a straight pattern. The second pattern begins at the byte position after the last byte of the first pattern.

---

**Preset Instrument  
Configurations**

## Introduction

This chapter lists the default settings for the three pre-defined PRESET instrument configurations and the four user PATTERNS.

They are accessed according to the following rules:

### PRESET 0 is used following:

- A press of the **INST PRESET** key
- An HP-IB command “ \*RST ”
- An HP-IB command “ SYSTem:PRESet ” or “ SYSTem:PRESet0 ”
- Power-on after installing new firmware
- Power-on with a different configuration of modules

### PRESET 1 is used following:

- A press of the **trigger & setup**, **recall setup** , **Preset 1** keys
- An HP-IB command “ SYSTem:PRESet1 ”

### PRESET 2 is used following:

- A press of the **trigger & setup**, **recall setup** , **Preset 2** keys
- An HP-IB command “ SYSTem:PRESet2 ”

## PRESET Instrument Configurations

Table 9-1 lists the HP 70843 PRESET 0 configuration and Tables 9-2 and 9-3 list the PRESET 1 and PRESET 2 configurations, respectively.

**Preset Instrument Configurations  
Introduction**

**Table 9-1 PRESET 0 Settings**

<b>Function</b>	<b>Preset State</b>
<b>Pattern</b>	
Pattern type	PRBS
PRBS pattern	$2^{23}-1$
ZSUB pattern	ZERO SUB $2^{13}$
zero substitution	13
MKDEN pattern	MARK DENSITY $2^{13}$
mark density	4/8
user pattern	straight patterns
user pattern 1 thru 12	not set to alternate pattern
alternate pattern source	Auxiliary Input
alternate pattern mode	alternate
alternate pattern half select	<b>A</b> half
<b>Pattern generator data output</b>	
data amplitude	500 mV
termination	0 V
data high level	0 V
$\overline{\text{data}}$ high level	0 V
data attenuation	0 dB
data polarity	NORMAL
data output control	ON
$\overline{\text{data}}$ output control	ON
data, $\overline{\text{data}}$ tracking	track
data output delay	0 ps

**Preset Instrument Configurations  
Introduction**

**Table 9-1 PRESET 0 Settings, continued**

<b>Function</b>	<b>Preset State</b>
<b>Pattern generator clock output</b>	
clock amplitude	500 mV
$\overline{\text{clock}}$ amplitude	500 mV
clock high-level	250 mV
clock attenuation	0 dB
clock termination	0 V
clock, $\overline{\text{clock}}$ tracking	track
<b>Slaved signal generator</b>	
clock frequency	1 GHz
frequency step	1 MHz
clock amplitude	+3 dB
clock output control	ON
<b>Error Add</b>	
external error add	OFF
internal error add	OFF
internal error add rate	1E-6
<b>Pattern generator subrate outputs</b>	
data termination	0V dc
data amplitude	500 mV
data high level	0 V
clock termination	0 V dc
clock amplitude	500 mV
clock high level	0 V

**Preset Instrument Configurations**  
**Introduction**

**Table 9-1**                      **PRESET 0 Settings, continued**

<b>Function</b>	<b>Preset State</b>
<b>Trigger</b>	
pat gen trigger pattern	all zeros
pat gen trigger mode	PATTERN SYNC
pat gen trigger bit position	0
pat gen trigger control for alternate pattern	once per input change
err det trigger mode	PATTERN SYNC
err det error output control	RZ
<b>Error detector input and eye</b>	
0/1 threshold mode	AUTOMATIC
0/1 threshold level	-1.3 Volts
data polarity	NORMAL
data termination	0 Volts
data input delay	0 ps
clock edge	POSITIVE
clock input termination	0 Volts
eye edge threshold	1.00E-3
<b>Error detector synchronization</b>	
sync mode	AUTOMATIC
sync threshold	1E-3
<b>Audio</b>	
on/off control	OFF
volume	1
audio sync loss	OFF

**Preset Instrument Configurations  
Introduction**

**Table 9-1 PRESET 0 Settings, continued**

<b>Function</b>	<b>Preset State</b>
<b>Gating</b>	
status	stopped
repeat mode	MANUAL
burst gating	OFF
duration mode	by TIME
by TIME gating period	1 minute
by ERRORS gating period	100 errors
by BITS gating period	1E10 bits
report mode	PREVIOUS
<b>Error Location</b>	
block mode	OFF
block start address	0
block length	32
bit error address	0
<b>Logging</b>	
status	OFF
Log-to device	External Controller
log alarms	OFF
log period report	full report
squelch status	OFF
trigger threshold	1.000E03
trigger 1 second	on errored second
trigger end period	always



**Preset Instrument Configurations  
Introduction**

**Table 9-1                    PRESET 0 Settings, continued**

<b>Function</b>	<b>Preset State</b>
<b>Miscellaneous</b>	
keyboard lock	OFF
HP-IB format of packed data	
used for passing large patterns	1 bit per byte
<b>Results</b>	
results window selection	main results
user's page selection	pattern
	Bit rate
	Pat gen clock freq
	Err det clock freq
	Error count
	Error ratio
	Errors
	0/1 threshold
	Sync mode
	Gating repeat mode
	Gating period
	Gating elapsed

**Preset Instrument Configurations  
Introduction**

## Preset 1 Configuration

PRESET 1 is defined as for PRESET 0, but with the following exceptions:

**Table 9-2                      PRESET 1 Settings**

<b>Function</b>	<b>Preset State</b>
<b>Pattern</b>	
pattern type	2 <sup>10</sup> -1
<b>Pattern generator data output</b>	
data amplitude	560 mV
$\overline{\text{data}}$ amplitude	560 mV
data high level	280 mV
$\overline{\text{data}}$ high level	280 mV
<b>Pattern generator clock output</b>	
clock amplitude	560 mV
$\overline{\text{clock}}$ amplitude	560 mV
clock high level	280 mV
$\overline{\text{clock}}$ high level	280 mV
<b>Pattern generator subrate outputs</b>	
data amplitude	560 mV
data high level	280 mV
Clock amplitude	560 mV
Clock high level	280 mV
<b>Results</b>	
result window selection	user's page
user's page selection	BIG error count

**Preset Instrument Configurations**  
**Introduction**

---

**Table 9-2**      **PRESET 1 Settings, continued**

<b>Function</b>	<b>Preset State</b>
	BIG error ratio
	Errors
	Pattern
	Err det clock freq
	Gating elapsed

**Preset Instrument Configurations**  
**Introduction**

## Preset 2 Configuration

PRESET 2 is defined as for PRESET 0, but with the following exceptions:

**Table 9-3**                      **PRESET 2 Settings**

<b>Function</b>	<b>Preset State</b>
<b>Pattern generator data output</b>	
data amplitude	560 mV
$\overline{\text{data}}$ amplitude	560 mV
data high level	280 mV
$\overline{\text{data}}$ high level	280 mV
<b>Pattern generator clock output</b>	
clock amplitude	560 mV
$\overline{\text{clock}}$ amplitude	560 mV
clock high level	280 mV
$\overline{\text{clock}}$ high level	280 mV
<b>Pattern generator subrate outputs</b>	
data amplitude	560 mV
data high level	280 mV
Clock amplitude	560 mV
Clock high level	280 mV
<b>Gating</b>	
repeat mode	SINGLE
by TIME gating period	30 seconds
<b>Logging</b>	
status	ON

**Preset Instrument Configurations  
User Pattern Default Settings**

**Table 9-3**                    **PRESET 2 Settings, continued**

<b>Function</b>	<b>Preset State</b>
Log-to device	HP-IB Printer
log alarms	ON
squelch status	ON
<b>Results</b>	
user's page selection	BIG error count
	BIG error ratio
	Errors
	Pattern
	Err det clock freq
	Gating elapsed

---

## **User Pattern Default Settings**

Four PATTERNS are available to the user, numbered 1 through 4. They are initially set to the following, and are accessed via the `pattern`, `ram` `Usr` `pattern` keys. They are as follows:

**Table 9-4**                    **User Pattern Default Settings**

<b>Pattern</b>	<b>Label</b>	<b>Length</b>
PATTERN 1	MDEN13_4	8192
PATTERN 2	MDEN11_4	2048
PATTERN 3	MDEN10_4	1024
PATTERN 4	MDEN7_4	128



---

**Data Logging**

### Introduction

The HP 71612 error performance analyzer can log measurement results via its rear-panel HP-IB interface to either a printer or an external controller.

The timestamped logging of results and alarms together with a configuration summary provides a straightforward means of generating a permanent record of, for example, a conformance test during equipment approval, or performance verification following installation.

The timestamping of the logged results is crucial for the analysis of time-varying results after long measurement periods where the instrument is unattended.

Where an electronic copy of the logged results is preferable, then logging to an external controller allows the logged results to be recorded in an ASCII text file with a minimum of programming. Refer to the **Programming Manual** when logging to a controller.

Refer to **Measurement Period** on page 4-22 for a description of the alternatives for defining continuous measurement periods know as *gating period*.

### Recommended Printers

The following printers are recommended:

- HP ThinkJet Printer Model 2225A (HP-IB).
- HP QuietJet Printer Model 2227A (HP-IB).
- HP DeskJet series of Printer Control Language (PCL) printers (Centronics).

### HP-IB (IEEE-488) to Centronics Printer Interface Converter

An HP-IB (IEEE-488) to Centronics interface converter is required for use with any printer with a Centronics interface. A suitable adaptor is the Intelligent Interfaces MicroPrint 45CH orderable under HP part number:

- ITEL-45CHVE for Europe.
- ITEL-45CHVU for North America/Japan/Korea/Taiwan.

To order the correct ac adapter specify:

- F1011A #ABU for UK.
- F1011A #ABB for rest of Europe.
- F1011A #ABG for Australia.
- F1011A #ACQ for South Africa.

The adaptor switches 1234 should be set to 1000 as the HP 70843 expects to log to an HP-IB printer at address 1.



## Data Logging

Switches 5678 on the Microprint 45CH should be set to 0000 so that the adaptor sends no resolution setting control to the printer. As there is no graphical output from the HP 70843 other settings of switches 5678 will not affect the quality or size of the logged output which is textual.

When using this interface adaptor the HP 70843 should be powered on last in order that it does not detect any violation of the IEEE-488 handshake protocol which may result from a power cycle of the adaptor. Any reconfiguration of the adaptor therefore requires the adaptor to be power-cycled which then requires a further power cycle of the HP 70843.

### Printer Interface Cables

- HP-IB cable HP 10833A (1 m), HP 10833B (2 m), HP 10833C (4 m) or HP 10833D (0.5 m).
- HP 92284A or HP 24542D Centronics 36-pin M, 25-pin M (2 m).

### Printer Address

The printer address is set permanently to 1, and cannot be changed by the user.

### Selecting Logging Functions

All logging functions are found by pressing the **logging** hardkey or by selecting **MENU** then the **logging** softkey. The following figure illustrates the logging softkeys available to the user.

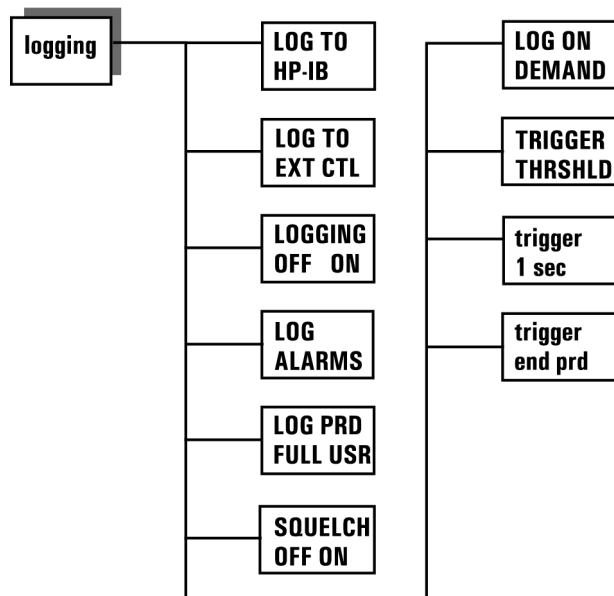

Data Logging Softkeys

### To Log Results to an HP-IB External Printer

#### Connecting a Printer

1. Connect a cable from the HP 70843 rear panel HP-IB port to an external printer.

#### To Log Results

2. Press the **logging** hardkey.
3. Set the **LOGGING OFF ON** soft key to **OFF**.
4. Check the setting of the **LOG TO HPIB** softkey.
  - When the key is active (underlined) the HP 71612 Series error detector is configured as a controller, and so allows results to be logged to an HP-IB printer.
  - If the key is not active then the error detector may be controlled via an external controller.
5. Switch ON the **LOG TO HPIB** softkey. The key is ON when it is underlined.
6. Select the type of logging you wish from the logging softkeys displayed.
7. Set the **LOGGING OFF ON** softkey **ON**.

The HP 71612 error performance analyzer is now configured to log results to an external printer.

### To Output Results via HP-IB to a Controller

As an alternative to outputting results to a printer, it is also possible to return results to a controller; the following procedure explains how to do this.

#### Procedure

1. Press the **logging** hardkey.
2. Set the **LOGGING OFF ON** softkey to **OFF**.
3. Switch ON the **LOG TO EXT CTL** softkey. The key is ON when it is underlined.
4. Set the **LOGGING OFF ON** softkey to **ON**.

The HP 71612 error performance analyzer is now configured to be controlled via a controller. Refer to the **Programming Manual** for detailed information on controller operation.

### When Measurement Results can be Logged

- Time stamped events during the measurement period (during gating).
- User selected or full results at the end of the measurement period.
- Current results at any time on demand.

### Logging During Gating

The events (triggers) which cause logging during gating are:

- On an errored second.
- On the error ratio exceeding a preset trigger threshold.

---

**NOTE** The two triggers listed above are mutually exclusive and cannot be changed while the **LOGGING OFF ON** softkey is set to **ON**.

---

### Logging Trigger Threshold

The logging trigger threshold is compared against one second error ratio values to determine when results are logged. The range of the trigger threshold is 1.0 to 1.0E-20 inclusive.

### Results Logged During Gating

- Error Count for the last second.
- Error Ratio for the last second.

Each set of results is stamped with the date and time of day.

### To Log Results During Gating

The following procedure explains how to configure an HP 71612 error performance analyzer system to log results during the gating period whenever the error ratio is >1.0E-07. Results are logged to an HP-IB printer.

#### Procedure

1. Press the **logging** hardkey.
2. Set the **LOGGING OFF ON** softkey to **OFF**.
3. Switch ON the **LOG TO HPIB** softkey (the softkey is underlined when ON).
4. Select **trigger 1 sec**, **LOG ON RAT>THR** then **exit**.
5. Press **TRIGGER THRSOLD**. Enter the desired trigger threshold using the numeric keypad then press **ENTER**. To set a 1.00E-07 threshold, enter 1.00 using the keypad, press the **e** softkey, enter 07 and press **ENTER**.
6. Set the **LOGGING OFF ON** softkey to **ON**.

The system is now configured to log results during gating whenever the error ratio is >1.00E-07.

### End of Measurement Period Logging

The following sets of results can be logged at the end of the measurement period: Selectable using the **LOG PRD FULLUSR** softkey.

- **LOG PRD FULL** Logs Main Results plus Interval Results plus G.821 Analysis
- **LOG PRD USR** Logs the results currently part of the *Users Page* (except delta error results).

### End of Measurement Logging Trigger

At the end of a measurement period the triggers to initiate logging are:

- Always
- Error Count >0
- Error Ratio > threshold (threshold range 1.0 to 1.0E-20)

---

**NOTE** The three triggers are mutually exclusive and cannot be changed while the **LOGGING OFF ON** softkey is set to **ON**.

---

### To Log Results at the End of the Measurement Period

The following procedure explains how to configure the HP 71612 error performance analyzer to log results selected on the *Users Page*, at the end of the measurement period when the error count >0. Results are logged to an HP-IB printer.

1. Configure the error performance analyzer to perform a measurement over a single or manual gating period.
2. Select the **logging** hardkey.
3. Set the **LOGGING OFF ON** softkey to **OFF**.
4. Switch ON the **LOG TO HPIB** softkey (the key is ON when it is underlined).
5. Select **trigger end prd**, **LOG END ERRS>0** then **exit**.
6. Set the **LOG PRD FULLUSR** softkey to **USR**. This sets the error detector data logger to log all the results selected on the *Users Page*.
7. Set the **LOGGING OFF ON** softkey to **ON**.

The error performance analyzer is now configured to log the *Users Page* results if, at the end of the measurement period the error count is greater than zero.

### Log On Demand

The **LOG ON DEMAND** softkey enables the user to log a single snapshot of the current results at the instant the key is pressed, irrespective of whether the system is gating or not, and whether logging is enabled or disabled. The output logged is dependent on the current state of the instrument, and is defined as follows:

- **LOGGING ON**, **GATING ON** ...results only logged
- **LOGGING OFF**, **GATING ON** ...header and results logged
- **LOGGING ON** or **OFF**, **GATING OFF** ...header and results logged

### Logging Alarms

When an alarm occurs and if the user has selected to have alarms printed, its cause (clock loss, data loss, sync loss), occurrence time and recovery time are printed. Power fail and recovery will always be printed regardless of whether alarms have been enabled or not. An example of Alarms logging is given below.

1993-04-23 23:10:04 ALARM: Power Failed

1993-04-23 23:10:14 Power Restored

1993-04-23 23:10:19 Gating Resumed

### To Log Alarms

Select **logging** then the **LOG ALARMS** softkey. The **LOG ALARMS** softkey is ON when it is underlined.

---

#### NOTE

In the event of a power failure, any results which were stored prior to being sent to the printer will be lost.

---

### Logging Squelch

The Squelch feature is intended to save paper in situations where logging is being triggered over a long period of time. When Squelch is enabled logging is inhibited if triggered for ten consecutive seconds. When Squelch is active a message similar to the following is logged:

1993-04-23 23:10:03 Squelching Printing

### To Squelch or not to Squelch

Only *during gating* triggers contribute to the decision on whether or not to squelch. Thus, the occurrence of *end of measurement* periods do not contribute, and are logged, if the user has indicated that they should, even when actively squelching.

## Data Logging

---

**NOTE** Squelching status continues through an end of measurement period.

---

That is, if actively squelching when an end of measurement period occurs, then at the start of the next measurement period the instrument will continue to squelch. Logging is resumed after one trigger free second. A message similar to the following is logged at the end of squelching.

1993-04-23 23:11:04 End of Squelching Printing

When squelching terminates the error count and error ratio are logged. Squelching has no effect when the **LOG ON DEMAND** softkey is used.

### Results Storage

An internal buffer is used to store results when the volume of results is greater than the print speed. If additional results occur when the buffer is full, then new results are discarded. The following message is logged each time the results buffer becomes full.

1993-04-23 16:12:44 Printing Results Buffer Overflow - Results Lost

Once the results buffer begins to empty, new results are then stored. No message is logged when this occurs.

### Results Storage when Logging is Switched On

When logging is switched ON the internal buffer used to store results is emptied. Disabling logging inhibits further storage of results but does not erase previously stored results.

---

**Performance Tests**

## Introduction

This chapter contains tests to verify the performance of the HP 71612 error performance analyzer system. Note that the HP 70340A clock source and HP 70341A clock source extension should be verified (by their performance tests) before proceeding, refer to the HP 70340A/70341A Operating and Calibration manual.

## Test Equipment Required

HP 54124T oscilloscope.

HP 34118A oscilloscope trigger.

HP 70004A display.

HP 70340A clock source.

HP 70341A clock source extension (or synthesizer generating 100 MHz to 1 GHz at 0 dBm).

HP 70001A mainframe (if HP 70341A is present).

HP 11667B power splitter.

HP 5386A frequency counter.

HP 71612 UHG pattern generator.

HP 8116A pulse generator.

SMA to SMA Cable (1 m) part number 8120-4948, 6 off.

HP 8490D #020 20 dB attenuator, 2 off.

HP 70800B cables, 4 off.

2.4 APC → 3.5mm adaptors, 2 off.

HP 11901C 3.5-inch floppy disk.

Performance verification of the HP 71612 products involves parametric testing of such features as rise and fall time of the Data/Clock outputs on the pattern generator. This is followed by the functional Performance Tests.



## Parametric Testing

### Preliminary setup

Connect the equipment as shown in Figure 11-1, below.

**NOTE** The HP 70341A and 70001A may be replaced by a synthesizer generating 100 MHz to 1 GHz at 0 dBm. This will require manual control of frequency in this range.

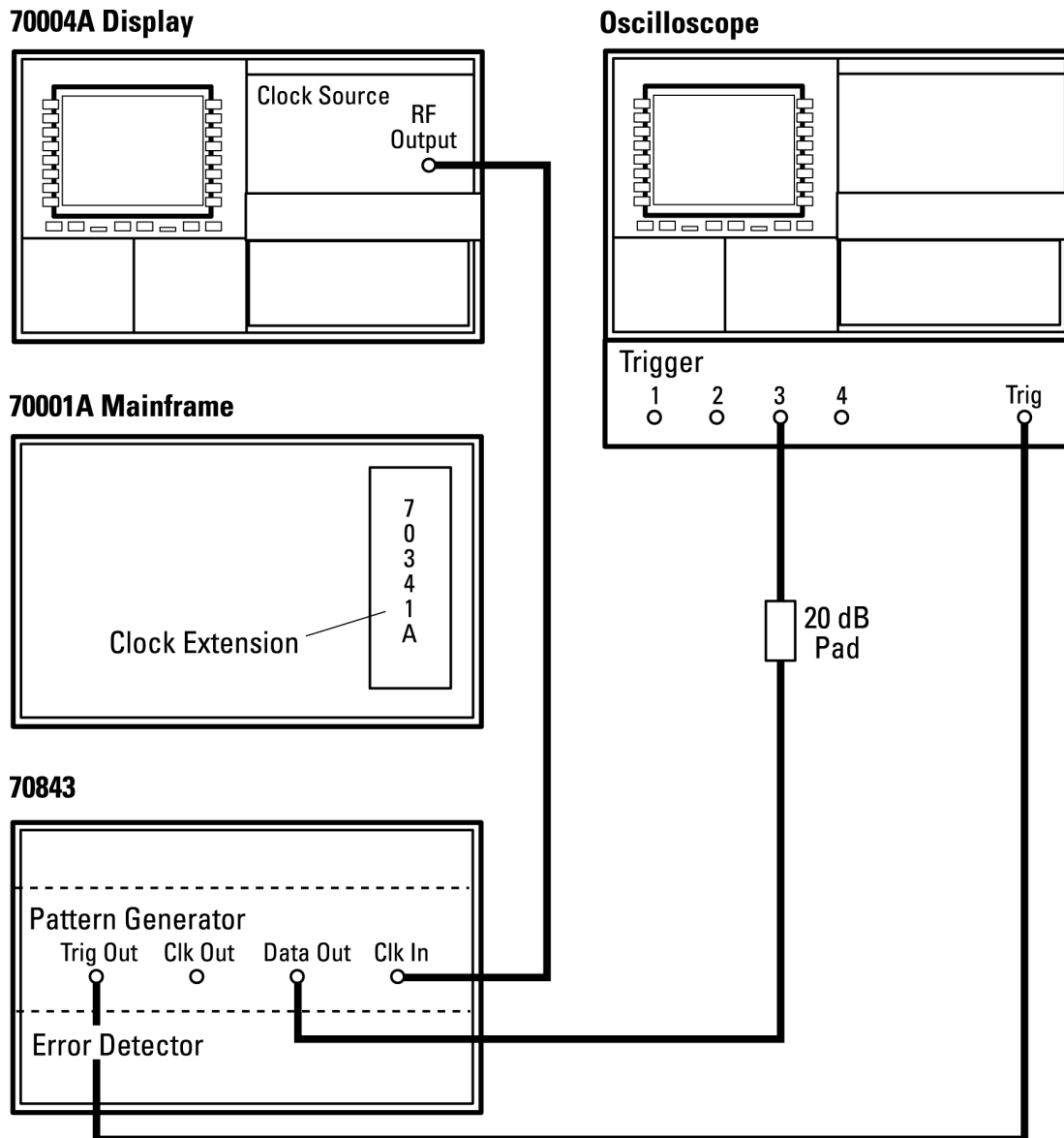

Figure 11-1 Preliminary setup

## Performance Tests

### Introduction

1. Switch on the equipment and allow the HP 71612 system to go through self test (approximately 20 seconds).
2. Perform the key sequence **INST PRESET**:
  - trigger & setup**  
Trigger set to CLK/8
  - clock output** set to 10 GHz at 2 Vpp. amplitude.
  - data output** set to 2 V amplitude with 0V Hi-level.

This will set the Pattern Generator to output a 2<sup>23</sup>-1 PRBS pattern at 10 Gb/s with Data amplitude 2 Vpp and a Hi-level of 0V.

\*Set the scope as follows:

AUTOSCALE

Timebase 20 ps/div

Set PROBE ATTEN to 10 (if the 20 dB pad is fitted in the trigger path)

Vertical sensitivity to 500 mV/div

Display set to PERSISTANCE mode (AVERAGE mode displays a flat line)

---

**NOTE** Scope Trigger should be adjusted for lowest jitter on rising and falling edges of the display signal.

---

### Data Risetime

1. On the scope DELTA Volts menu, switch the V Markers ON and set MARKER 1 to the lower level of the signal (midway into the noise band). Set MARKER 2 to the Hi level of the signal (midway into the noise band).
2. Press Preset Level 0 to 100% on the scope. This will automatically move markers 1 and 2 to 10 and 90% levels.
3. Center a rising edge transition on the scope display and expand the timebase to 10 ps/div.
4. On the scope DELTA T menu, switch the markers on and set the START MARKER to the crossover of the V marker on the 10% level of the rising edge (midway into the edge noise or jitter). Set the STOP MARKER to the crossover of the V marker at the 90% level (midway into the edge noise or jitter).
5. Read the DELTA T value from the bottom of the scope display. Enter this value of DATA RISETIME on the Calibration Data sheet.

### Data Falltime

1. Perform the **Preliminary setup** if this has not already been done.
2. On the scope DELTA Volts menu, switch the V Markers ON and set MARKER 1 to the lower level of the signal (midway into the noise band). Set MARKER 2 to the Hi level of the signal (midway into the noise band).

## Performance Tests

### Introduction

3. Press Preset Level 0 to 100% on the scope. This will automatically move markers 1 and 2 to 10 and 90% levels.
4. Center a falling edge transition on the scope display and expand the timebase to 10 ps/div.
5. On the scope DELTA T menu, switch the markers on and set the START MARKER to the crossover of the V marker on the 90% level of the falling edge (midway into the edge noise or jitter). Set the STOP MARKER to the crossover of the V marker at the 10% level (midway into the edge noise or jitter).
6. Read the DELTA T value from the bottom of the scope display. Enter this value of DATA FALLTIME on the Calibration Data sheet.

### Data Jitter

1. Perform the **Preliminary setup** if this has not already been done.
2. Use the scope timebase delay to view 8 sequential “EYE CROSSOVER”s. Use the **worst** jittered eye crossover to perform the remainder of this procedure.
3. Center the eye crossover in the middle of the display. The scope timebase delay shown at the top of the display should be in the region of 18 ns. **It must not be near 16 ns** as a discontinuity in the scope occurs at this value and may cause measuring anomalies.
4. Select the scope MORE followed by HISTOGRAM menu and the SOURCE to Channel 3.
5. Select VOLTS Histogram and move the WINDOW MARKERS 1 and 2 as shown in Figure 11-2.

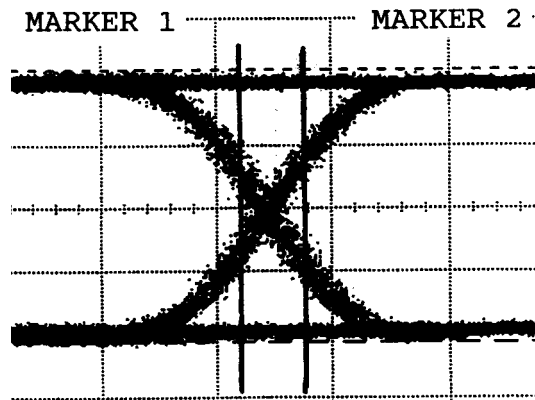

Figure 11-2

6. Press the ACQUIRE key on the scope, set the number of samples to 1000 and then press the START ACQUIRING key on the scope (the acquisition progress can be observed at the top right hand side of the scope display as an increasing percentage value).

## Performance Tests

### Introduction

- Note the histogram which has been plotted. The peak of this histogram defines the voltage level where the “EYE CROSSOVER” occurs. Record this voltage level.
- Press the upper right key on the scope to show WINDOW and select Time histogram. Locate the START marker approximately 20 mV below the EYE CROSSOVER and the STOP marker approximately 20 mV above the EYE CROSSOVER.
- Press the ACQUIRE key on the scope, set the number of samples to 1000 and then press the START ACQUIRING key on the scope (the acquisition progress can be observed at the top right hand side of the scope display as an increasing percentage value).
- Press RESULTS and note the histogram which has been plotted. Locate the LOWER DISTRB MARKER at the far left of this histogram and the UPPER DISTRB MARKER at the far right of the histogram.
- Read the DELTA T value from the bottom of the scope display. Enter this value of DATA JITTER on the Calibration Data sheet.

### Data (inverted) Risetime

- Perform the **Preliminary setup** with the exception: re-connect the cable from channel 3 on the scope to the DATA port.
- On the scope DELTA Volts menu, set MARKER 1 to the lower level of the signal (midway into the noise band). Set MARKER 2 to the Hi level of the signal (midway into the noise band).
- Press Preset Level 0 to 100% on the scope. This will automatically move markers 1 and 2 to 10 and 90% levels.
- Center a rising edge transition on the scope display and expand the timebase to 10 ps/div.
- On the scope DELTA T menu, set the START MARKER to the crossover of the V marker on the 10% level of the rising edge (midway into the edge noise or jitter). Set the STOP MARKER to the crossover of the V marker at the 90% level (midway into the edge noise or jitter).
- Read the DELTA T value from the bottom of the scope display. Enter this value of DATA RISETIME on the Calibration Data sheet.

### Data (inverted) Falltime

- Perform the **Preliminary setup** with the exception: re-connect the cable from channel 3 on the scope to the DATA port.
- Center a falling edge transition on the scope display and expand the timebase to 10 ps/div.
- On the scope DELTA Volts menu, set MARKER 1 to the lower level of the signal (midway into the noise band). Set MARKER 2 to the Hi level of the signal (midway into the noise band).
- Press Preset Level 0 to 100% on the scope. This will automatically move markers 1 and 2 to 10 and 90% levels.

## Performance Tests

### Introduction

5. On the scope DELTA T menu, set the START MARKER to the crossover of the V marker on the 90% level of the falling edge (midway into the edge noise or jitter). Set the STOP MARKER to the crossover of the V marker at the 10% level (midway into the edge noise or jitter).
6. Read the DELTA T value from the bottom of the scope display. Enter this value of DATA FALLTIME on the Calibration Data sheet.

### Data (inverted) Jitter

1. Perform the **Preliminary setup** if this has not already been done.
2. Use the scope timebase delay to view 8 sequential “EYE CROSSOVER”s. Use the worst jittered eye crossover to perform the remainder of this procedure.
3. Center the eye crossover in the middle of the display. The scope timebase delay shown at the top of the display should be in the region of 18 ns. It must not be near 16 ns as a discontinuity in the scope occurs at this value and may cause measuring anomalies.
4. Select the scope MORE followed by HISTOGRAM menu and the SOURCE to Channel 3.
5. Select VOLTS Histogram and move the WINDOW MARKERS 1 and 2 as shown in Figure 11-3.

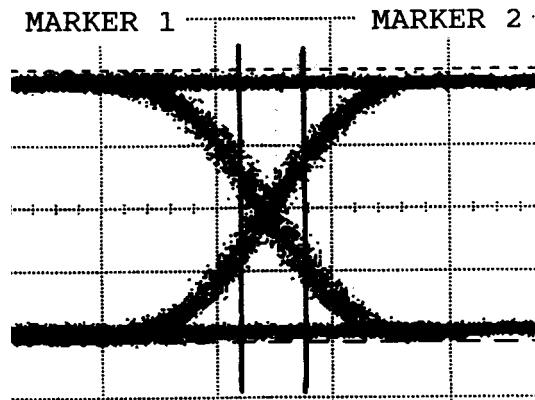

Figure 11-3

6. Press the ACQUIRE key on the scope, set the number of samples to 1000 and then press the START ACQUIRING key on the scope (the acquisition progress can be observed at the top right hand side of the scope display as an increasing percentage value).
7. Note the histogram which has been plotted. The peak of this histogram defines the voltage level where the “EYE CROSSOVER” occurs. Record this voltage level.
8. Press the upper right key on the scope to show WINDOW and select Time histogram. Locate the START marker approximately 20 mV below the EYE CROSSOVER and the STOP marker approximately 20 mV above the EYE CROSSOVER.

## Performance Tests

### Introduction

9. Press the **AQUIRE** key on the scope, set the number of samples to 1000 and then press the **START AQUIRING** key on the scope (the acquisition progress can be observed at the top right hand side of the scope display as an increasing percentage value).
10. Press **RESULTS** and note the histogram which has been plotted, locate The **LOWER DISTRB MARKER** at the far left of this histogram and the **UPPER DISTRB MARKER** at the far right of the histogram.
11. Read the **DELTA T** value from the bottom of the scope display. Enter this value of **DATA JITTER** on the Calibration Data sheet.

### Adjacent Bit-length Test

This test verifies that all bits (data eyes) are the same length along the x-axis.

1. Perform the **Preliminary setup** if this has not already been done.
2. Adjust the scope timebase to show 2 data eyes.
3. Verify that both data eyes are the same length along the x-axis. If this is not the case, contact the factory at [tntd\\_support@ agilent.com](mailto:tntd_support@agilent.com)

### Clock Risetime

1. Perform the **Preliminary setup** with the following exception: re-connect the cable from channel 3 on the scope to the **CLOCK OUT** port on the pattern generator.
2. On the scope **DELTA Volts** menu, set **MARKER 1** to the lower level of the signal (midway into the noise band). Set **MARKER 2** to the Hi level of the signal (midway into the noise band).
3. Press **Preset Level 0 to 100%** on the scope. This will automatically move markers 1 and 2 to 10 and 90% levels.
4. Center a rising edge transition on the scope display and expand the timebase to 10 ps/div.
5. On the scope **DELTA T** menu, set the **START MARKER** to the crossover of the V marker on the 10% level of the rising edge (midway into the edge noise or jitter). Set the **STOP MARKER** to the crossover of the V marker at the 90% level (midway into the edge noise or jitter).
6. Read the **DELTA T** value from the bottom of the scope display. Enter this value of **CLOCK RISETIME** on the Calibration Data sheet.

### Clock Falltime

1. Perform the **Preliminary setup** with the following exception: re-connect the cable from channel 3 on the scope to the **CLOCK OUT** port on the pattern generator.
2. On the scope **DELTA Volts** menu, set **MARKER 1** to the lower level of the signal (midway into the noise band). Set **MARKER 2** to the Hi level of the signal (midway into the noise band).
3. Press **Preset Level 0 to 100%** on the scope. This will automatically move markers 1 and 2 to 10 and 90% levels.

## Performance Tests

### Introduction

4. Center a rising edge transition on the scope display and expand the timebase to 10 ps/div.
5. On the scope DELTA T menu, set the START MARKER to the crossover of the V marker on the 10% level of the rising edge (midway into the edge noise or jitter). Set the STOP MARKER to the crossover of the V marker at the 90% level (midway into the edge noise or jitter).
6. Read the DELTA T value from the bottom of the scope display. Enter this value of CLOCK FALLTIME on the Calibration Data sheet.

### Clock (inverted) Risetime

1. Perform the **Preliminary setup** with the following exception: re-connect the cable from channel 3 on the scope to the CLOCK OUT port on the pattern generator.
2. On the scope DELTA Volts menu, set MARKER 1 to the lower level of the signal (midway into the noise band). Set MARKER 2 to the Hi level of the signal (midway into the noise band).
3. Press Preset Level 0 to 100% on the scope. This will automatically move markers 1 and 2 to 10 and 90% levels.
4. Center a rising edge transition on the scope display and expand the timebase to 10 ps/div.
5. On the scope DELTA T menu, set the START MARKER to the crossover of the V marker on the 10% level of the rising edge (midway into the edge noise or jitter). Set the STOP MARKER to the crossover of the V marker at the 90% level (midway into the edge noise or jitter).
6. Read the DELTA T value from the bottom of the scope display. Enter this value of CLOCK RISETIME on the Calibration Data sheet.

### Clock (inverted) Falltime

1. Perform the **Preliminary setup** with the following exception: re-connect the cable from channel 3 on the scope to the CLOCK OUT port on the pattern generator.
2. On the scope DELTA Volts menu, set MARKER 1 to the lower level of the signal (midway into the noise band). Set MARKER 2 to the Hi level of the signal (midway into the noise band).
3. Press Preset Level 0 to 100% on the scope. This will automatically move markers 1 and 2 to 10 and 90% levels.
4. Center a rising edge transition on the scope display and expand the timebase to 10 ps/div.
5. On the scope DELTA T menu, set the START MARKER to the crossover of the V marker on the 10% level of the rising edge (midway into the edge noise or jitter). Set the STOP MARKER to the crossover of the V marker at the 90% level (midway into the edge noise or jitter).
6. Read the DELTA T value from the bottom of the scope display. Enter this value of CLOCK FALLTIME on the Calibration Data sheet.

---

## Pattern Generator Tests

Connect the equipment as shown in Figure 11-4 and switch on the system. Press **INST PRESET** on the HP 70004A display to initialize the HP 70843 pattern generator and proceed as follows:

### Clock Input Minimum Level Alarm

1. Connect the clock source RF output via a power splitter to the pattern generator and power meter as shown in Figure 11-4. Set the RF output level to 10 GHz at 0 dBm.

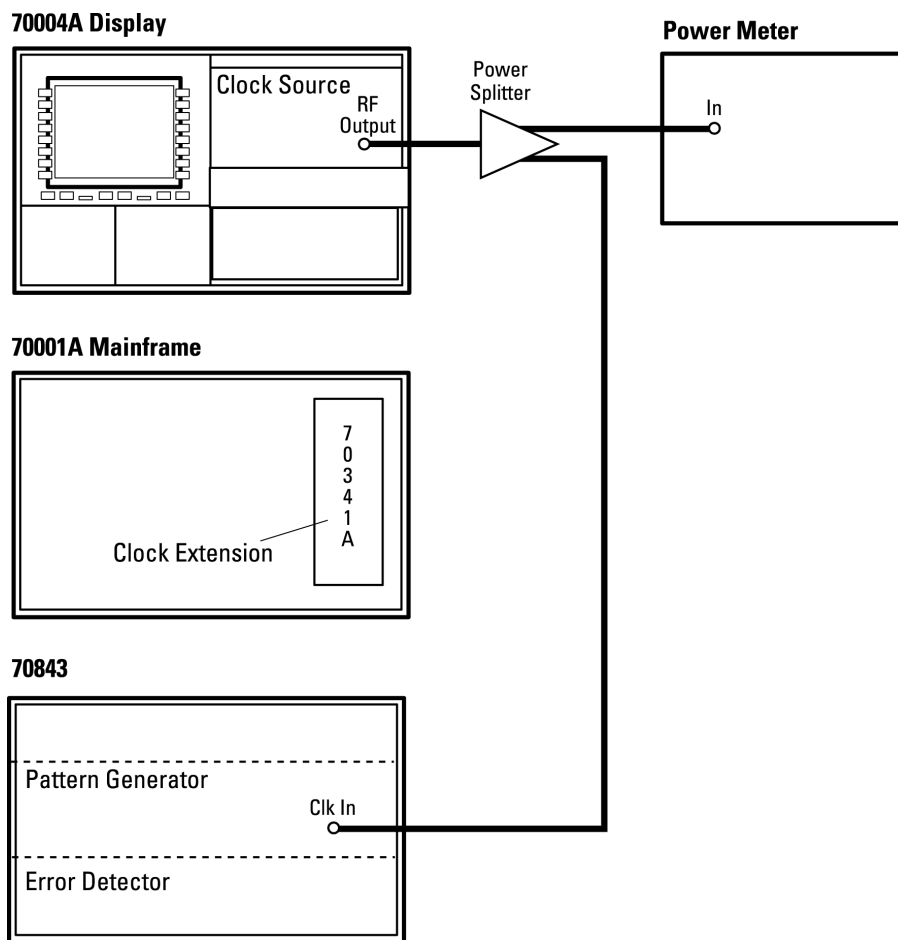

Figure 11-4

2. Reduce the power output from the clock source until the display indicates **clock loss** and the **CLK LOSS** LED on the front panel is illuminated. Ensure that the power output level is less than  $-3$  dBm.



Performance Tests  
 Pattern Generator Tests

**Clock Out and Clock (inverted) Out Amplitude and Frequency**

1. Connect the HP 70843 main CLOCK OUT ports to the oscilloscope as shown in Figure 11-5. Press **INST PRESET**

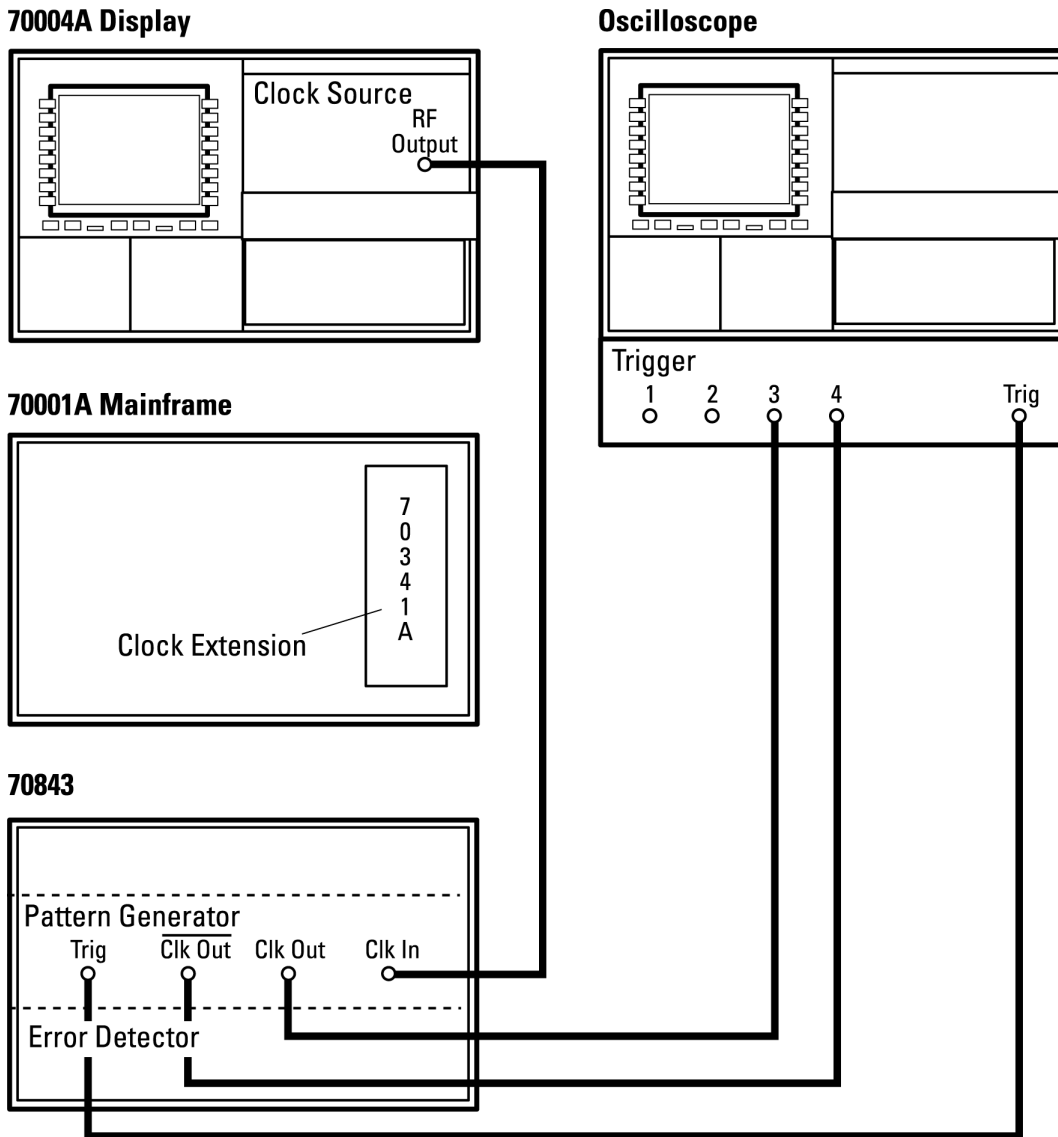

Figure 11-5

2. Set the CLOCK and  $\overline{\text{CLOCK}}$  outputs to track each other. Press **clock output** then set **C/TRACK** to ON.
3. Set the clock frequency to 10 GHz at 0 dbm.
4. Set the pattern generator Pattern Trigger to trigger on clock (select **trigger & setup** and set **PG TRIG PAT CLK** to **CLK** ).

**Performance Tests**  
**Pattern Generator Tests**

5. Verify that both output can be varied to the specifications given in Table 11-1:

**Table 11-1**

**Clock Output Amplitude**

Parameter	Value
High Output Level	$\leq +1.5\text{ V}$
Low Output Level	$\geq -3\text{ V}$
Minimum Amplitude	0.5 V pp nom
Maximum Amplitude	2.0 V pp nom

6. Press **clock output**, **clock Hi-level**, use the RPG control to set the Hi-level to its maximum (1.5 V).
7. Press **clock amplitd**, use the RPG control to set the clock amplitude to its maximum level (2 V).
8. Select only the Clock scope channel to be ON.
9. Press Autoscale on the scope and select the DELTA V markers ON.
10. Set Marker 2 to the trough of the signal and Marker 1 to the peak of the signal. Read Marker 1 as the “High Output level” and  $\Delta V$  as the “Maximum amplitude”. Enter these values in the Performance Test Record.
11. Press **clock output**, **clock Hi-level** use the RPG control to set the Hi-level to its minimum (-3V).
12. Press **clock amplitd**, use the RPG control to set the clock amplitude to its minimum level (500 mV).
13. Set Marker 2 to the trough of the signal and Marker 1 to the peak of the signal. Read Marker 1 as the “Low Output level” and  $\Delta V$  as the “Minimum amplitude”. Enter these values in the Performance Test Record.
14. Repeat 1 to 13 with only the  $\overline{\text{CLOCK}}$  scope channel ON, to obtain  $\overline{\text{CLOCK}}$  amplitude and Hi-level readings. These should also be entered on the Performance Test Record.
15. Set both the Clock and  $\overline{\text{Clock}}$  channels to ON. Press **clock output**, **C/TRACK** to be OFF.
16. Repeat steps 1 to 7 for both channels, ensuring that each signal is independently adjustable.
17. Set the CLOCK and  $\overline{\text{CLOCK}}$  outputs NOT to track each other as follows: Select **clock output** then set **C/TRCK ON OFF** to **OFF**
18. Verify that both outputs can be varied independently to the specifications given in Table 11-1.

### Data Out and Data (inverted) Out Amplitude

1. Connect the system as shown in Figure 11-6.

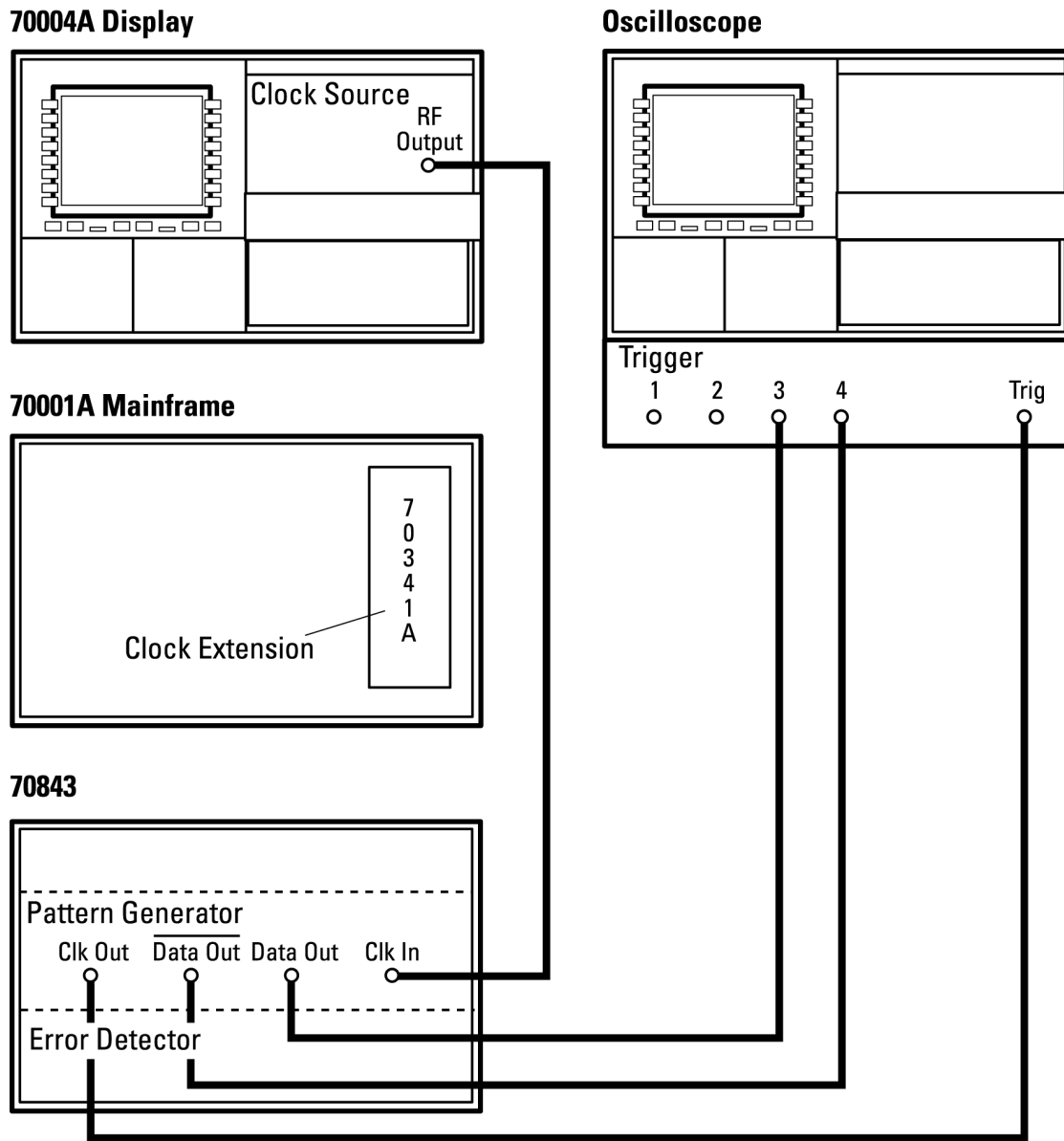

Figure 11-6

2. Set the DATA and  $\overline{\text{DATA}}$  outputs to track each other. Press **data output** and set **D/TRACK** to ON.

**Performance Tests**  
**Pattern Generator Tests**

3. Verify that both output can be varied to the specifications given in Table 11-2.

**Table 11-2**

**Data Output Amplitude**

Parameter	Value
High Output Level 0V termination	$\leq +1.5$ V nom
Low Output Level	$\geq -3$ V nom
Minimum Amplitude	0.5 V pp nom
Maximum Amplitude	2.0 V pp nom

4. Press **data output**, **Data Hi-level**, use the RPG control to set the Hi-level to its maximum (1.5 V).
5. Press **Data amplitd**, use the RPG control to set the Data amplitude to its maximum level (2V).
6. Select only the Data scope channel to be ON.
7. Press Autoscale on the scope and select the DELTA V markers ON.
8. Set Marker 2 to the trough of the signal and Marker 1 to the peak of the signal. Read Marker 1 as the “High Output level” and  $\Delta V$  as the “Maximum amplitude”. Enter these values in the Performance Test Record.
9. Press **data output**, **Data Hi-level**, use the RPG control to set the Hi-level to its minimum ( $-3$  V).
10. Press **Data amplitd**, use the RPG control to set the Data amplitude to its minimum level (300 mV).
11. Set Marker 2 to the trough of the signal and Marker 1 to the peak of the signal. Read Marker 1 as the “Low Output level” and  $\Delta V$  as the “Minimum amplitude”. Enter these values in the Performance Test Record.
12. Repeat 1 to 8 with only the  $\overline{\text{DATA}}$  scope channel ON, to obtain  $\overline{\text{Data}}$  amplitude and Hi-level readings. These should also be entered on the ON.
13. Set both the DATA and  $\overline{\text{DATA}}$  channels to ON. Press **data output**, **D/TRACK** to be OFF.
14. Repeat steps 1 to 7 for both channels, ensuring that each signal is independently adjustable.
15. Verify that both outputs can be varied to the specifications given in Table 11-2.
16. Set the DATA and  $\overline{\text{DATA}}$  outputs NOT to track each other. Select **data output** then **D/TRACK** to off.
17. Verify that both outputs can be varied independently to the specifications in Table 11-2.

Performance Tests  
Pattern Generator Tests

### Data Delay

1. Connect the pattern generator clock and data outputs to the oscilloscope as shown in Figure 11-7 and set up a 1010 pattern at 1.0 Gb/s. Set the pattern generator Pattern Trigger to trigger on Pattern.

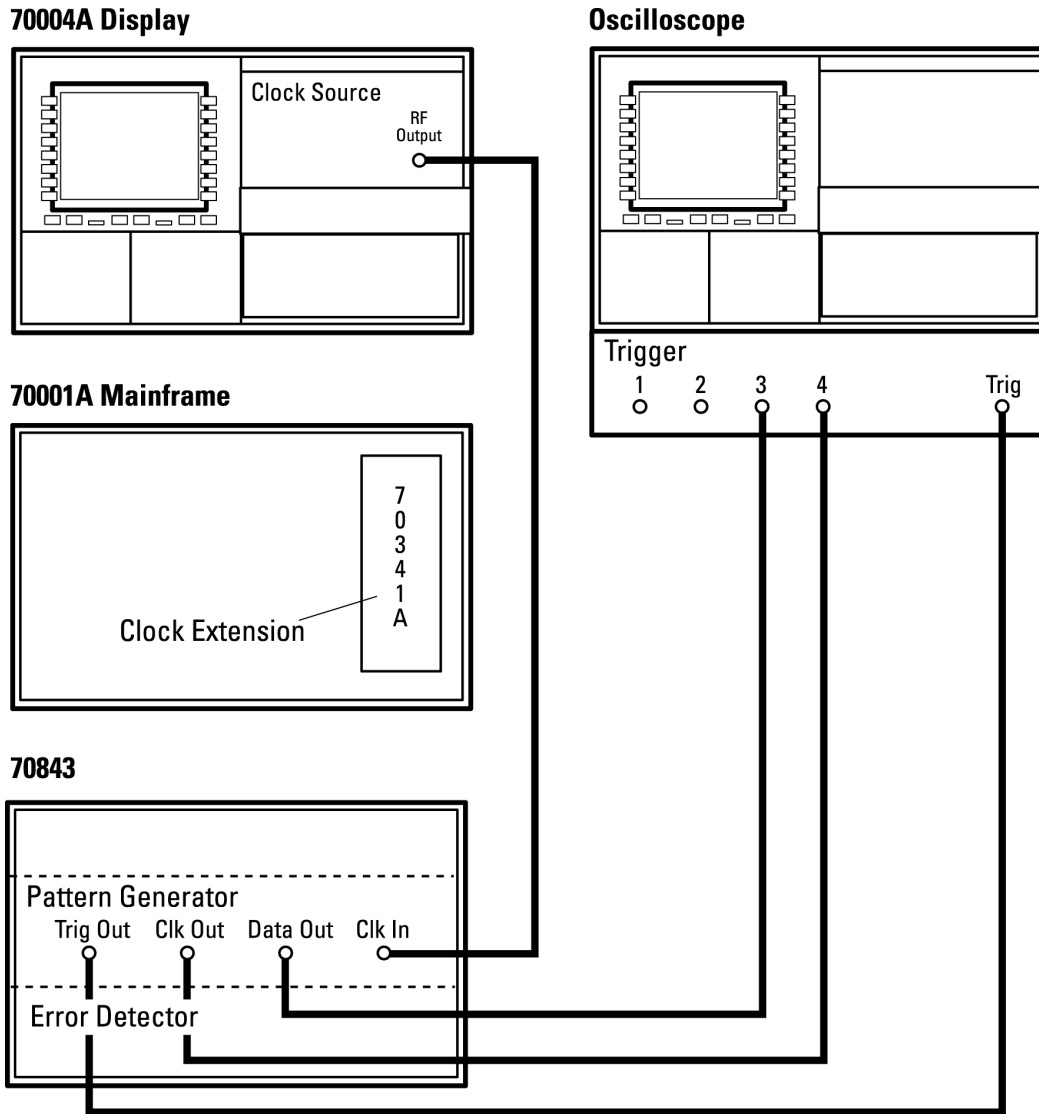

Figure 11-7

2. Select **data output**, **DATA DELAY** and use the RPG control to adjust the delay between clock and data to read 0 ps.
3. Ensure that the clock signal can be moved over a range of  $\pm 1$  ns relative to the *data eye*.
4. Repeat steps 1 to 3 for data rates of 4.5, 9 and 12 Gb/s, ensuring that the shift available is  $\pm 1$  clock period long.

**Performance Tests**  
**Pattern Generator Tests**

5. Activate the Autoscale function on the scope and set the DELTA T Markers to be ON.
6. Set the STOP Marker on the last rising clock pulse edge on the right hand side of the scope display.
7. Using the RPG control, increase the delay to its maximum, observing the selected rising edge move across the display.
8. Set the START Marker to the final position of the rising edge and record the DELTA T value (clk/data delay) on the Performance Test Record.
9. Set the delay to 0 ps.
10. Set the STOP Marker on the first rising clock pulse edge on the left hand side of the scope display.
11. Using the RPG control, decrease the delay to its minimum, observing the selected rising edge move across the display.
12. Set the START Marker to the final position of the rising edge and record the DELTA T value (clk/data delay) on the Performance Test Record.

Performance Tests  
 Pattern Generator Tests

### Pattern Generator Trigger Output

1. Connect the equipment as shown in Figure 11-8.

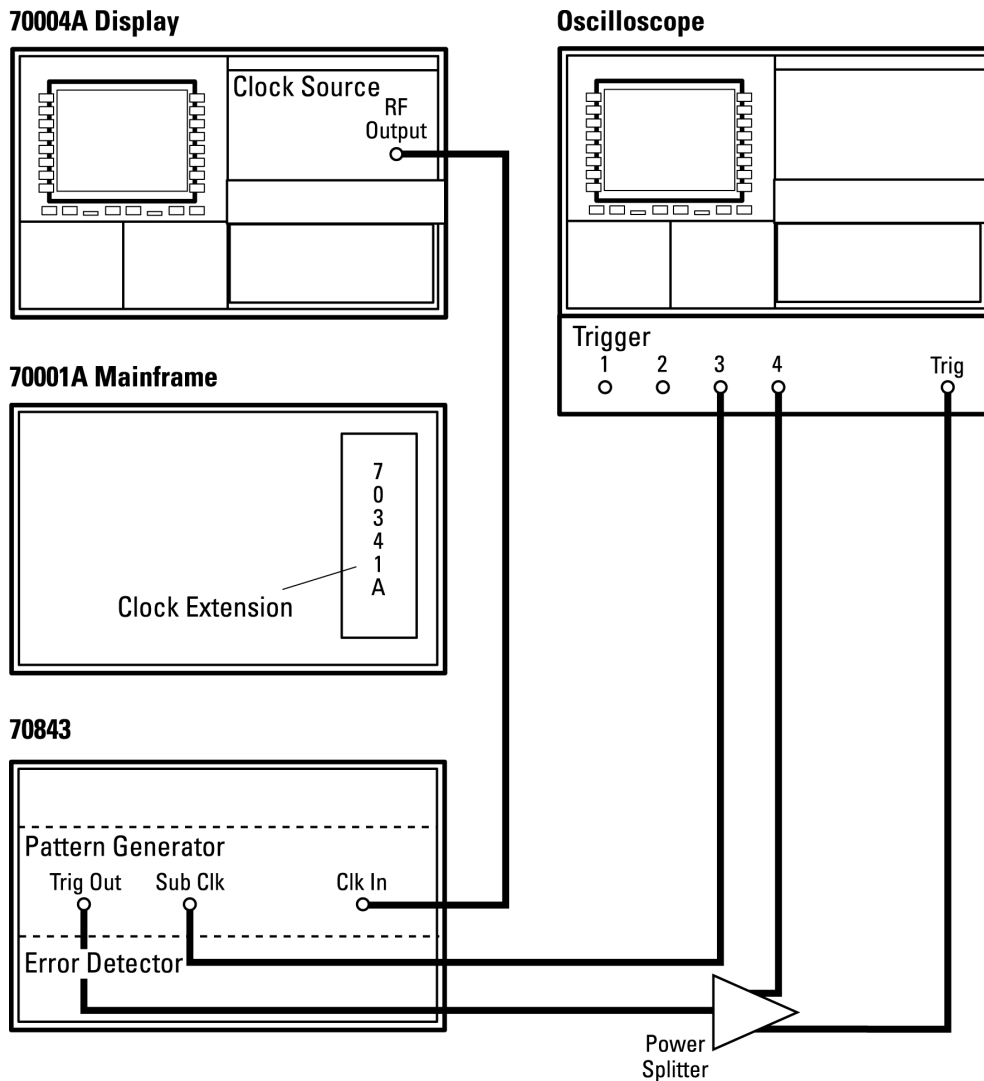

Figure 11-8

2. Press the **INST PRESET** key on the display. Set the Trigger mode to CLK/32, and ensure the trigger pulse has an equal mark-space ratio and a period of 32 clock cycles. Set the Trigger mode to CLK/8, and ensure the trigger pulse has an equal mark-space ratio and a period of 8 clock cycles.
3. Set the pattern generator Trigger mode to PATTERN (set **PG TRIG PAT CLK** to **PAT**). Select **Pattern**, **MARK DEN**, **2<sup>7</sup> MARKDEN**.
4. Verify that the trigger pulse is a mark, 32 clock periods wide (each substrate clock period on channel 3 is 4 clock periods wide)

Performance Tests  
Pattern Generator Tests

### Subrate Clock Out

1. Re-connect the equipment as shown in Figure 11-9 and set the clock output frequency to 10 GHz.

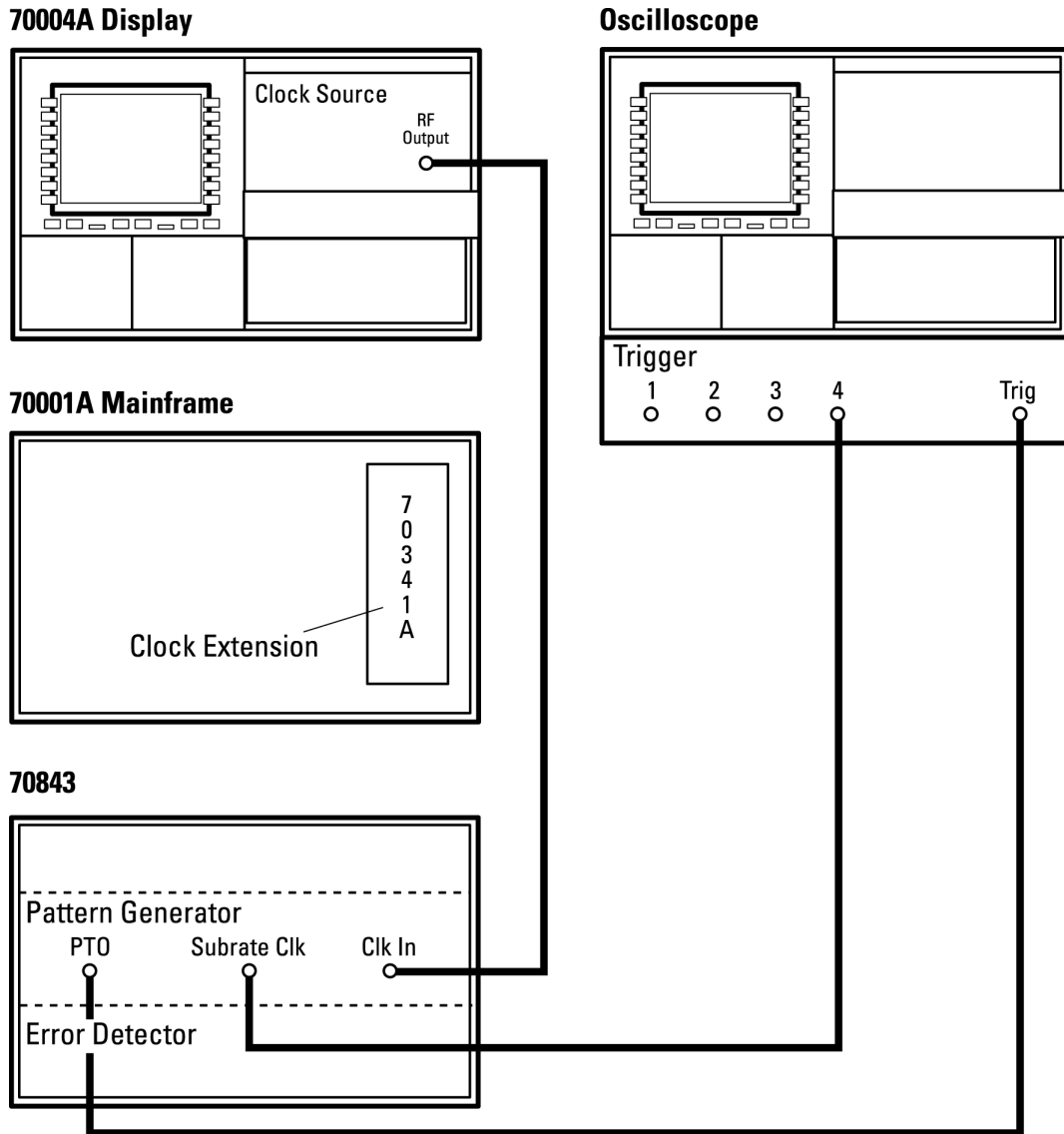

Figure 11-9

2. Check that the output amplitude and offset can be adjusted within the specifications given in Table 11-3.
3. Press **subrate outputs**, **S/R CLK Hi-level**, use the RPG control to set the Hi-level to its maximum (0V).



**Performance Tests**  
**Pattern Generator Tests**

4. Press **S/R CLK amplitd**, use the RPG control to set the clock amplitude to its maximum level (1 V).
5. Press Autoscale on the scope and select the DELTA markers ON.
6. Set Marker 2 to the trough of the signal and Marker 1 to the peak of the signal. Read Marker 1 as the “High Output level” and 0V as the “Maximum amplitude”. Enter these values in the Performance Test Record.
7. Press **S/R CLK Hi-level**, use the RPG control to set the Hi-level to its minimum (-1.5 V).
8. Press **S/R CLK amplitd**, use the RPG control to set the clock amplitude to its minimum level (500 mV).
9. Set Marker 2 to the trough of the signal and Marker 1 to the peak of the signal. Read Marker 1 as the “Low Output level” and 0V as the “Minimum amplitude”. Enter these values in the Performance Test Record.

Performance Tests  
Pattern Generator Tests

### Parallel Data/4 Outputs

1. Re-connect the equipment as shown in Figure 11-10.

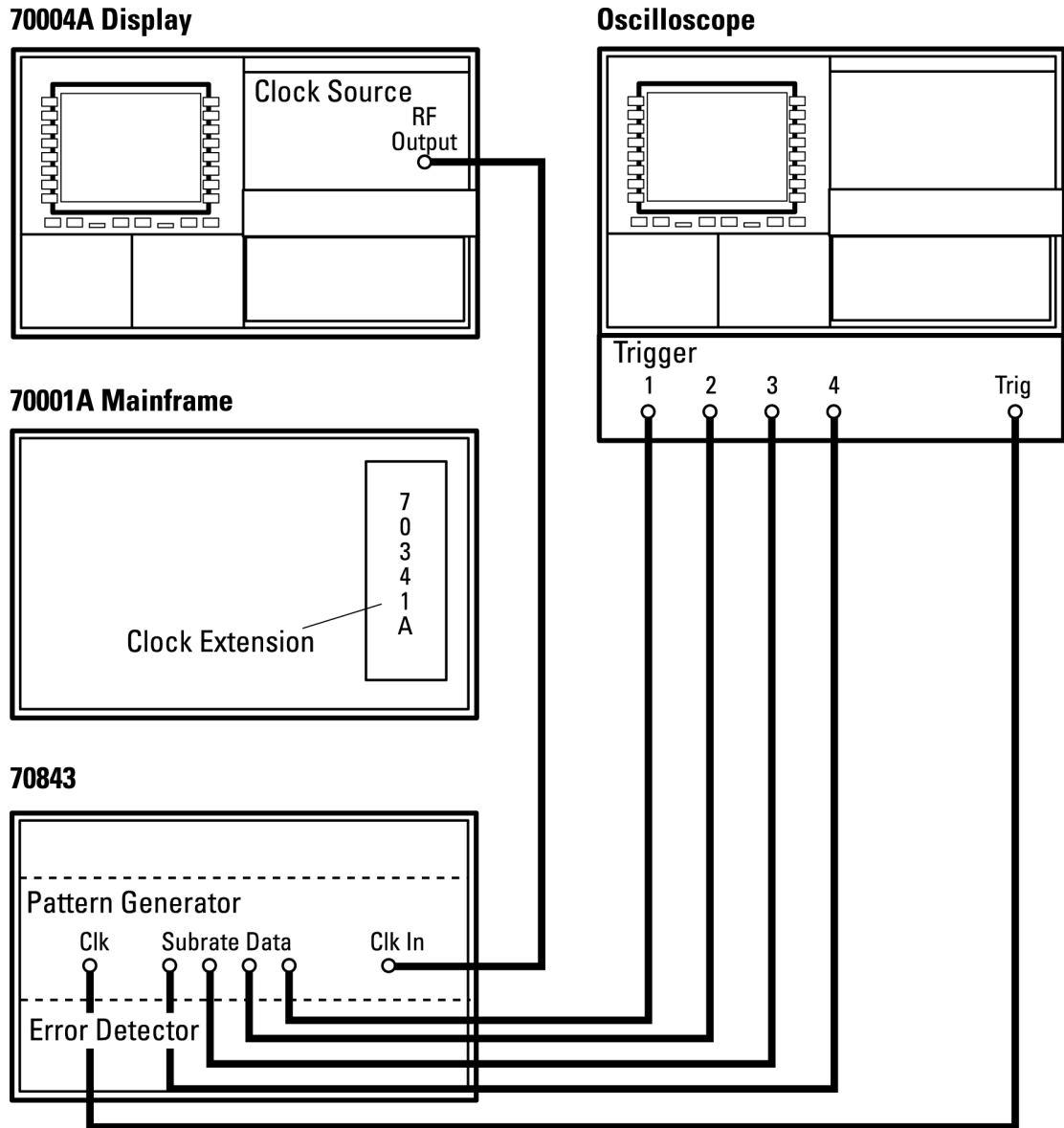

Figure 11-10

2. Set up the 16-bit pattern 1000 0100 0010 0001.
3. Check that all four waveforms are similar, a negative going mark followed by three spaces.
4. Check the relative phases of each of the subrate outputs on the oscilloscope; they should be out of phase by one bit with respect to each other.

**Performance Tests**  
**Pattern Generator Tests**

5. Press **subrate outputs**, **S/R DAT Hi-level**, use the RPG control to set the Hi-level to its maximum (0V).
6. Press **S/R DAT amplitd**, use the RPG control to set the clock amplitude to its maximum level (1 V).
7. Press Autoscale on the scope and select the DELTA V markers ON.
8. Set Marker 2 to the trough of the signal and Marker 1 to the peak of the signal. Read Marker 1 as the “High Output level” and 0V as the “Maximum amplitude”. Enter these values in the Performance Test Record.
9. Press **S/R DAT Hi-level**, use the RPG control to set the Hi-level to its minimum (-1.5 V).
10. Press **S/R DAT amplitd**, use the RPG control to set the clock amplitude to its minimum level (500 mV).
11. Set Marker 2 to the trough of the signal and Marker 1 to the peak of the signal. Read Marker 1 as the “Low Output level” and 0V as the “Minimum amplitude”. Enter these values in the Performance Test Record.
12. Check that the amplitude and offset can be adjusted as shown in Table 11-3. Greater reading accuracy will be achieved if the channels are viewed one at a time.

**Table 11-3**

**Subrate Clock & Data Output Amplitude/Offset**

<b>Parameter</b>	<b>Value</b>
High Output Level	$\leq +0V$
Low Output Level	$\geq -1.5 V$
Minimum Amplitude	0.5 V pp nom
Maximum Amplitude	1.0 V pp nom

Performance Tests  
Pattern Generator Tests

### Auxiliary Input (Alternate word switchover)

1. Connect a pulse generator to the AUXILIARY INPUT port on the pattern generator front panel as shown in Figure 11-11.

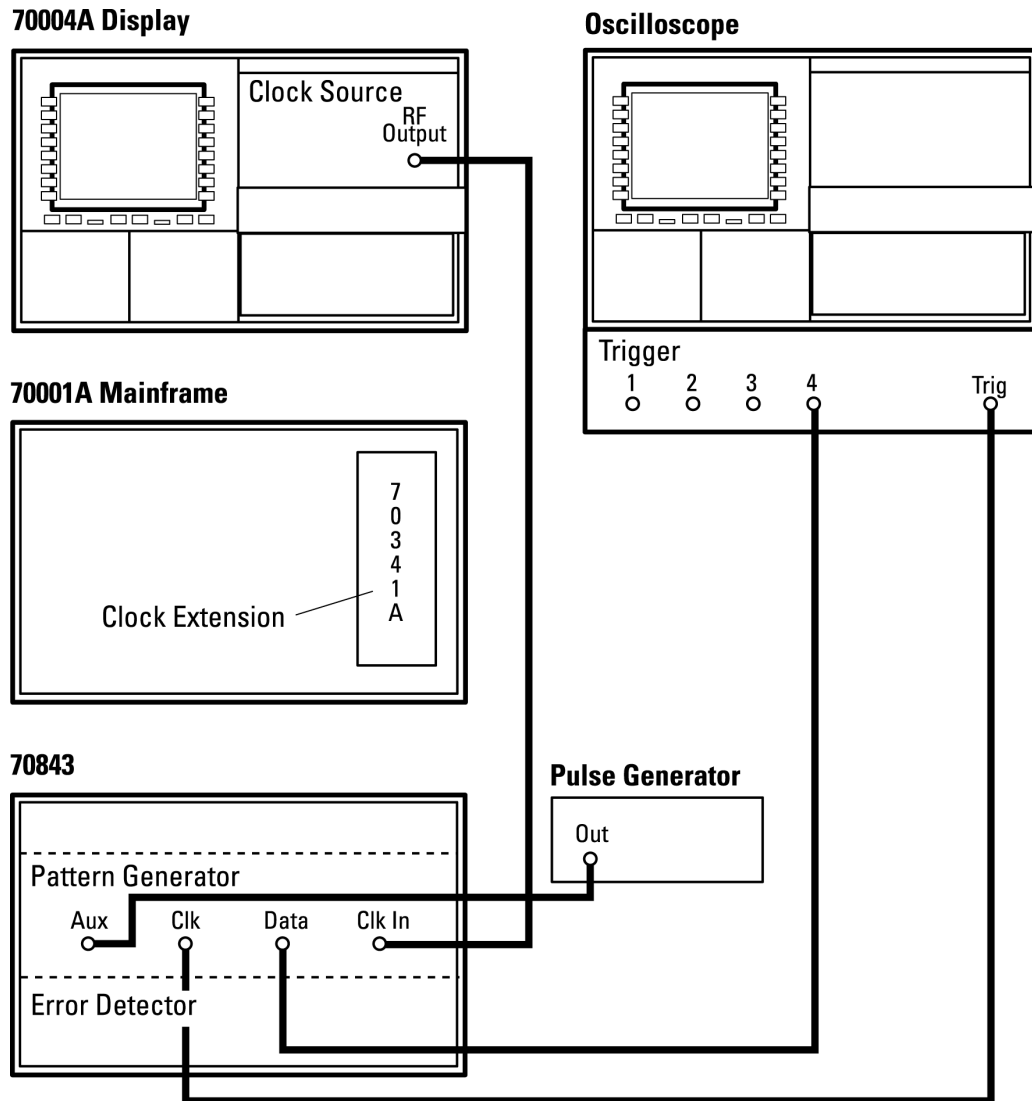

Figure 11-11

2. Set the pulse generator to supply a TTL level pulse with 3 sec on time and 3 sec off time.
3. Setup an alternate pattern with halves A and B as follows. Setup the A pattern to be 10101010 and the B pattern to be 11110000, both repetitive for a pattern length of 8 bits.
4. Check the pattern on the oscilloscope and verify that it alternates between pattern A and pattern B.

### Error Inject (internal and external)

1. Connect a pulse generator to the pattern generator ERROR INJECT INPUT port and connect a frequency counter as shown in Figure 11-12.

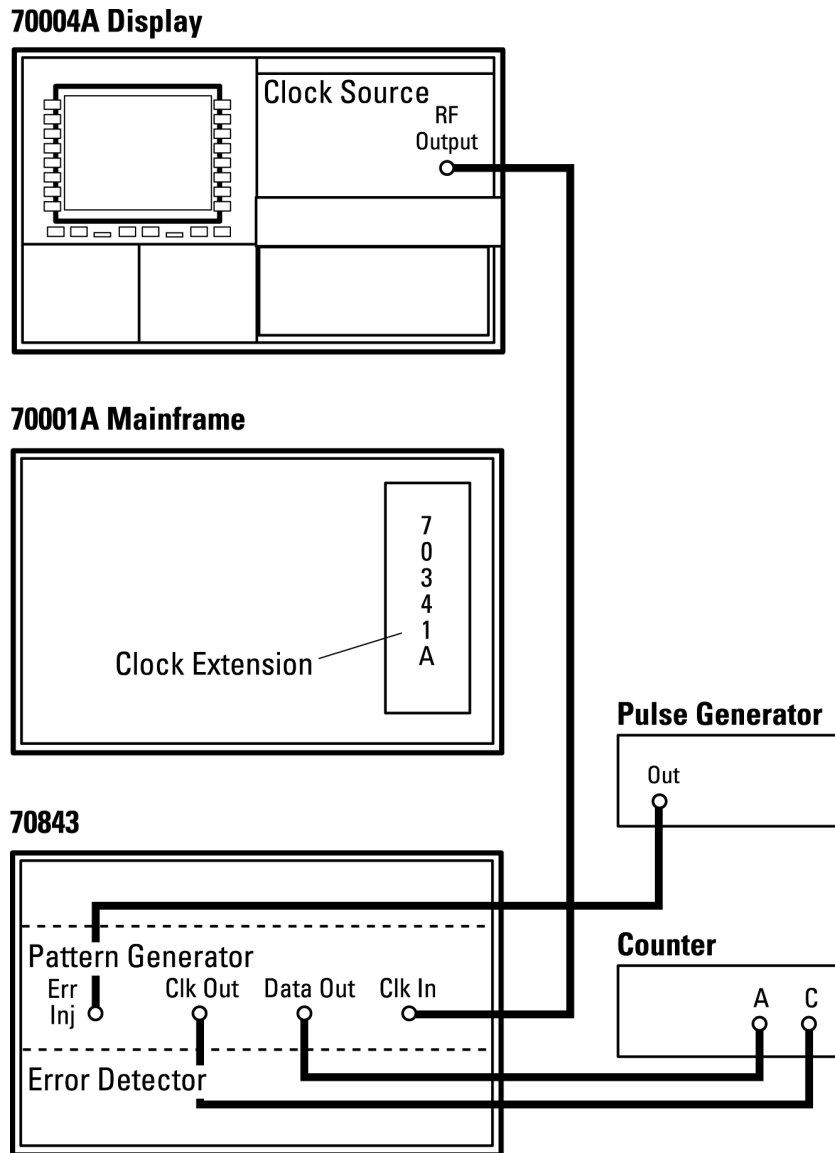

Figure 11-12

2. Set up a 00000000 pattern at 1 Gb/s.

### Single error inject

3. Select the **error add** key. Press the **ERR-ADD SINGLE** key and verify that the gating LED on the A channel of the counter illuminates each time this key is pressed.

**Performance Tests**  
**Pattern Generator Tests**

**Fixed error inject**

4. Select **ERR-ADD FIXED** and a value of **1e-9**. Verify the reading on the counter to be 1 Hz.
5. Repeat step 5 for all error rates up to 1E-3. Verify corresponding counter readings of 10 Hz to 1 MHz.

**External error inject**

6. Set the pulse generator to output a TTL level, 100 ns wide pulse at a frequency of 1 Hz.
7. Verify the reading on the frequency counter to be 1 Hz.
8. Using the range control on the pulse generator, increase the pulse frequency through 10 Hz to 1 MHz. Verify frequency counter readings from approximately 10 Hz to 1 MHz.

---

## Error Detector Performance Tests

Ensure the pattern generator used in the following tests has passed all performance tests and meets its published specifications.

### Clock Input Level Alarm

1. Connect the clock source RF output to the error detector CLOCK INPUT port and to the power meter via a power splitter as shown in Figure 11-13.

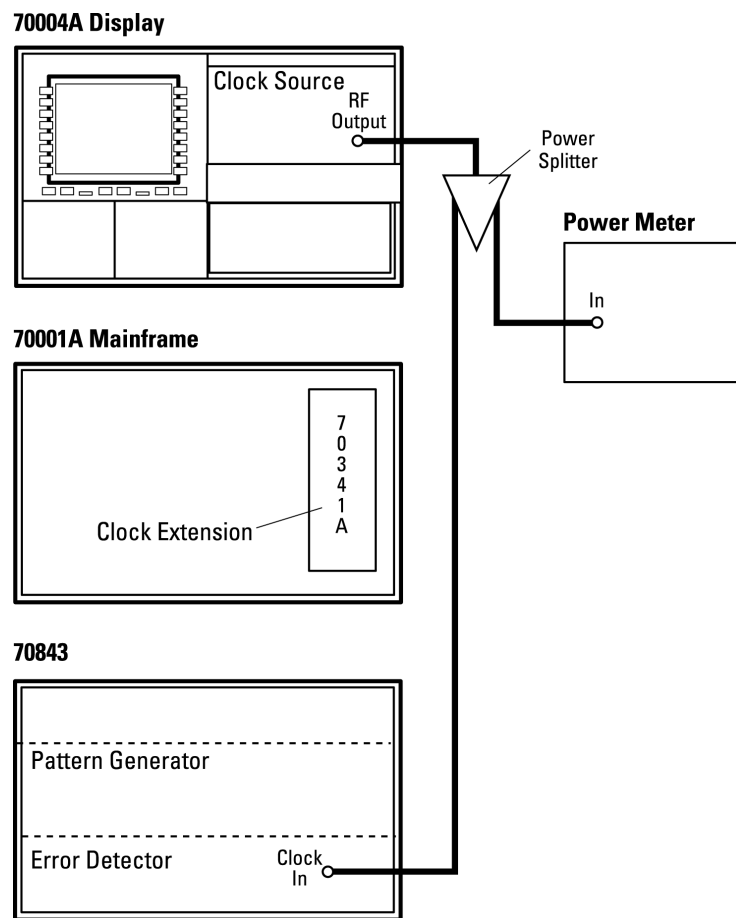

Figure 11-13

2. Set the clock source frequency to 10 GHz and output level to 0 dBm. The clock loss alarm should be off.
3. Reduce the output level of the clock source until the clock loss alarm appears on the display and the CLOCK LOSS LED is illuminated on the HP 70843 front panel. This should occur at a power level less than or equal to  $-3$  dBm.

Performance Tests  
Error Detector Performance Tests

## Pattern Sync Output

1. Connect the equipment as shown in Figure 11-14.

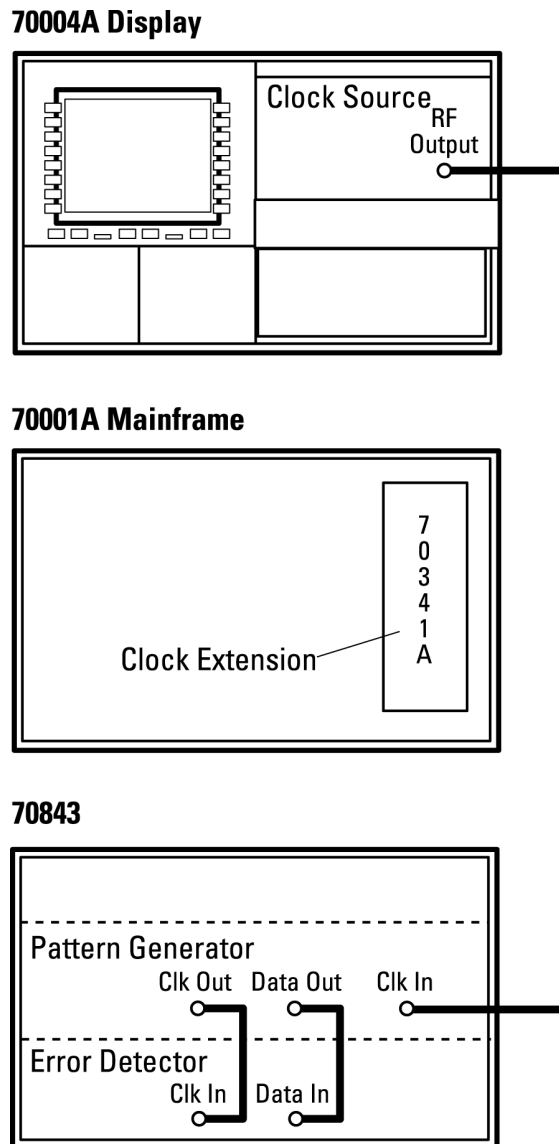

Figure 11-14

2. Press the **INST PRESET** key on the display. Select **trigger & setup** and set **ED TRIG PAT CLK** to **CLK**. Ensure the trigger pulse has equal mark-space ratio and a period of 8 clock cycles. Set the clock frequency to 16 Hz.
3. Set the **ED TRIG PAT CLK** softkey to **PAT**, **Pattern**, **PRBS**,  $2^7-1$ .
4. Verify that the trigger pulse is a mark, 32 clock periods wide (each subrate clock period on channel 3 is 4 clock periods wide) use the base and delay.



Performance Tests  
Error Detector Performance Tests

### Gating Input & Error Measurement

1. Press the **sync & audio** key. Switch the **AUDIO ON/OFF** hardkey to **OFF**.
2. Select **error add**, **ERR-ADD FIXED**.
3. Select error rates from 1E-3 to 1E-9 inclusive and verify that the correct error rate is displayed.

### Error Out

1. With the equipment set up as in Figure 11-15, select a fixed error rate of 1E-3.

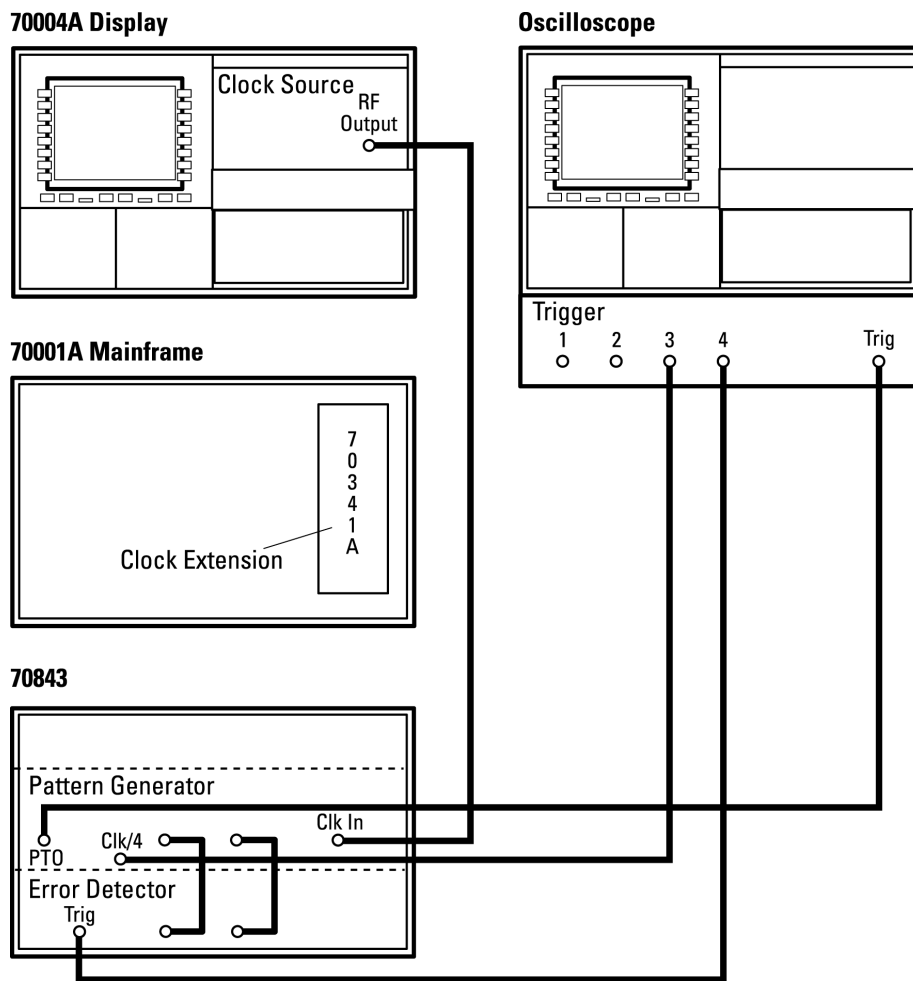

Figure 11-15

2. Press **INSTR PRESETUP**. Select **trigger & setup** and set **ERR O/P RZ200ns** to **RZ**.
3. The reading on the frequency counter should be  $1 \times 10^6$ .

**Performance Tests**  
**Error Detector Performance Tests**

## **Audible Error Output**

1. Select **sync & audio** and set **AUDIO ON OFF** to **ON** . Set the Audio output volume to level 1 (as displayed in the error detector synchronization and audio control window.) Set the sync threshold to 1E-1.
2. Set up the pattern generator to generate single errors (select **error add** , **ERR-ADD SINGLE** .)
3. Select **ERR-ADD SINGLE** and verify that the system emits a short audible tone burst.
4. Select **ERR-ADD FIXED** , **1e-9** and verify that the instrument emits similar tone bursts to the previous one but spaced approximately at one second intervals.
5. Press the **1e-8** to **1e-3** keys in sequence and verify that a continuous tone rising in pitch is emitted for each successive key press.
6. Press **sync & audio** followed by **AUDIO VOLUME** . Using the RPG control, verify that the tone volume increases and the displayed audio volume goes from 1 to 15.

## **Data 0/1 Threshold Auto/Manual Test**

**Configure the equipment as in Figure 11-15.**

1. Press **INST PRESET** followed by **input & eye** .
2. Record the value of the 0/1 Threshold setting from the display which should nominally 250 mV with no sync loss or errors.
3. Return the 0/1 Threshold AUTO/MAN setting to MAN.
4. Press the **data output** key and adjust the DATA offset level to -2.000 V and DATA amplitude to 2.000 V.
5. Press the **input & eye** key and set the **0/1 Threshold AUTO/MAN** key to **AUTO** . Record the 0/1 threshold value from the display. This should be nominally -3 V with no sync loss or errors.
6. Return the **0/1 Threshold AUTO/MAN** setting to **MAN** .
7. Press **data output** and adjust the DATA offset level to +1.5 V.
8. Press the **input & eye** key and set the **0/1 Threshold AUTO/MAN** key to **AUTO** . Record the 0/1 threshold value from the display. This should be nominally 500 mV with no sync loss or errors.
9. Return the **0/1 Threshold AUTO/MAN**, press the **0/1 Manual Threshold** key and verify that the threshold value can be adjusted within the range 1.000 V to -3.000 V (sync and data loss may occur as this operation is performed).

**Performance Tests**  
**Error Detector Performance Tests**

**Clock/Data Align**

1. Press the **data output** hardkey followed by the **DATA DELAY** key.
2. Adjust the data delay slowly via the RPG control until sync loss occurs. This will be highlighted on the HP 70004A display.
3. Press **input & eye** followed by the **CLK-DAT ALIGN** softkey.
4. Verify that the Delay value shown on the lower left of the display changes and sync is achieved after 5 seconds.

**Data Input Sensitivity**

1. Connect the equipment as shown in Figure 11-16.

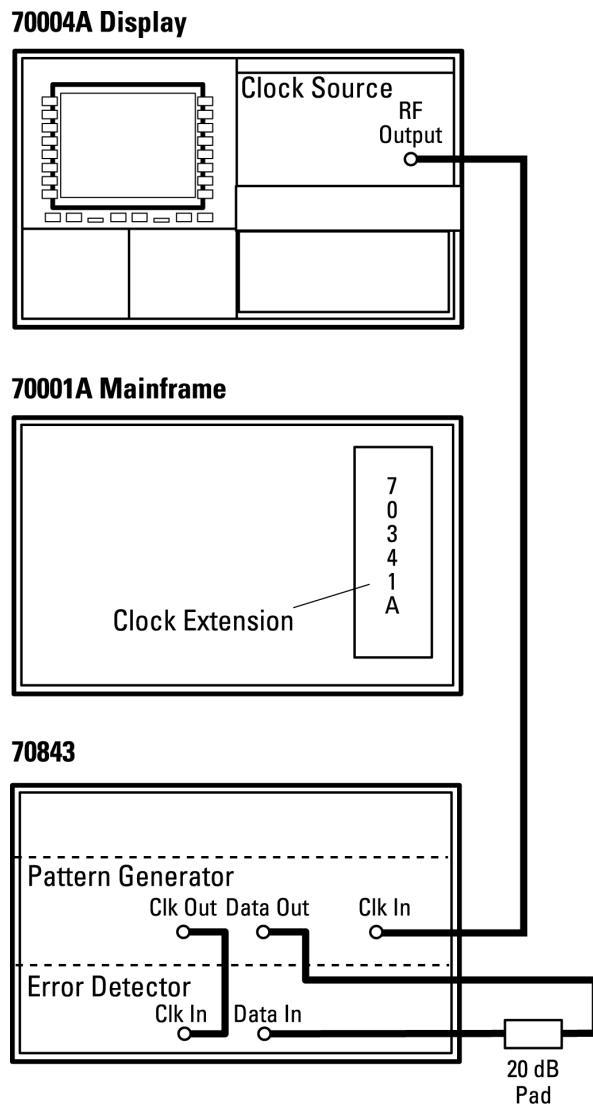

**Figure 11-16**

**Performance Tests**  
**Error Detector Performance Tests**

2. Press **INST PRESET** and set the Clock Output Sig Gen Freq to 10 GHz, the Data output amplitude to 2 Vpp with a Data Hi-level of 0V. A  $2^{23}-1$  PRBS pattern will now be output from the pattern generator to the error detector.
3. Press the **input & eye** key and set the **Eye Edge Threshold** to  $1 \times 10^{-7}$  followed by **ENTER** .
4. Press **0/1 Threshold Center**, a value of approximately  $-120$  mV will be present on the HP 70004A display.
5. Ensure that the system is in Sync and showing 0 errors before continuing. Press the **CLK DAT** align key if this is not so.
6. Press **data output** followed by **Data Amplitude** and reduce the Data amplitude slowly until errors start to occur.
7. Press **input & eye** followed by **0/1 Manual Threshold**. Adjust the 0/1 threshold towards 0V slowly. The display should now read 0 errors. Continue to adjust 0/1 Threshold until errors start to occur again.
8. Press **data output** followed by **Data Amplitude** and reduce the Data amplitude slowly until the display shows 0 errors. Continue to reduce the Data amplitude until errors begin to occur once more.
9. Steps 7 and 8 should be repeated until it is no longer possible to find an error-free zone or until the Data amplitude reads 500 mV.
10. If an error free zone can no longer be found then the value of Data Amplitude/10 is entered on the Calibration Data sheet for the input sensitivity. If the Data amplitude reaches 500 mV then the figure 50 mV is entered for the Input sensitivity.

## Pattern Verification

This test only applies to HP 71612 option UHF systems. With the equipment connected as shown in Figure 11-13, press **INST PRESET** on the HP 70004A display.

1. Set the CLOCK frequency to 100 Mb/s. Ensure that the error detector is in sync and the error count/ratio is 0 (error and sync loss flags on the display should be off).
2. Repeat 1 for all other PRBS patterns.
3. Repeat 1 and 2 for data rates of 1, 4.5, 9 and 12 Gb/s.

## Floppy Disk Read/Write

1. Insert a blank unformatted high density floppy disk into the disk drive.
2. Use the format command in the pattern generator and ensure the disk formats with no errors. (Select **pattern**, **disk utils**, **FORMAT DISK**)
3. Edit a user pattern and save it to DISK PATT 5.
4. Erase the current pattern and load DISK PATT 5, ensure that the pattern which was saved is now the current pattern.
5. Repeat steps 3 to 4 for DISK PATTS 6 through 12.
6. Change the data rate to 9, 4.5, 1 Gb/s and 100 Mb/s in turn and ensure that the error detector syncs up with no errors in all cases.

---

**NOTE** This test takes 12 hours to complete and may be performed after all other tests (including parametric testing) have been completed if necessary.

---

## Residual Error Rate Test

Configure the equipment as in Figure 11-15.

1. Press **INST PRESET** followed by **clock output** and set the output frequency to 12 GHz. This will set the HP 71612 to  $2^{31}-1$  PRBS pattern at 12 Gb/s.
2. Allow the setup to run for 12 hours and check the error rate on the display after this period. The error rate should be  $<10^{-14}$ .

## Performance Tests

### To Verify/Demonstrate the Capture Error Feature (Option UHJ instruments)

---

## To Verify/Demonstrate the Capture Error Feature (Option UHJ instruments)

The following procedure can be used to demonstrate capturing an error, or verify that the instrument is operating correctly in this mode. It also teaches you how to select an alternate pattern and add errors to one half of the alternate pattern.

For this procedure, an alternate pattern is selected and errors added to pattern B.

1. Connect the equipment as shown in Figure 11-13 on page 11-25.
2. Select **[pattern]**, **edit ram usr** then an **INTERNAL PATT** store - for this example select **INTERNAL PATT1**.
3. Set **ALTPATT ON OFF** to **ON** then select **YES**. This sets the length of the pattern in **INTERNAL PATT1** to 1.
4. Select **SETPAT LENGTH** then enter a pattern length of 4000 using the numeric keypad - press **ENTER**. If you press **toggle screen** you can view the pattern on a full screen.
5. Check that the **INSERT REPLACE** key is set to **REPLACE**.
6. Load a PRBS into each half of the alternate pattern as follows:
7. Set the cursor on bit 0 of half A (half A is the uppermost pattern) then select **load block, 2^13 prbs, NO MODIFY**.
8. Use the **[▼]** and **goto** keys to set the cursor on bit 0 of half B.
9. Select **load block, 2^13 prbs, NO MODIFY**. Add errors to pattern B by changing bits 224 and 360.
10. Select **save pattern, INTERNAL PATT1**.
11. Select **[pattern]** and set **ALTPAT AUX USR** to **USR** and **ALTPAT HALF AB** to **B**. Note that the red **Errors** flag is illuminated.
12. Select **[error location]** and press **CAPTURE ERROR**. Note that the *Bit error address* in the Error location configuration control window indicates an error in bit 224, - press **CAPTURE ERROR** again and the address changes to 560.
13. End of procedure.

**Performance Tests**  
**HP 70843 option UHF Line Final Test Data**

**HP 70843 option UHF Line Final Test Data**

Serial Number			
Options			
Test Procedure No.	A-708343-90115-1		
Tested by		Date	

**Performance Test Record**

Page No.	Test Description	Result		
		Min	Actual	Max
11-10	Clock Input Min. Level Alarm	N/A		-4dB
11-12	<b>Tracking On</b> Clock offset High Output Level Clock Amplitude Max Output Level Clock offset Low Output Level Clock Amplitude Min Output Level  $\overline{\text{Clock}}$ offset High Output Level $\overline{\text{Clock}}$ Amplitude Max Output Level $\overline{\text{Clock}}$ offset Low Output Level $\overline{\text{Clock}}$ Amplitude Min Output Level	1.35 V 1.8 V N/A 400 mV  1.35 V 1.8V N/A 400 mV		1.65 V 2.2 V -2.7 V 600 mV  1.65 V 2.2 V 2.7 V 600 mV
11-14	Data High Low Output Level Data Amplitude Max Output Level Data offset Low Output Level Data Amplitude Min Output Level  $\overline{\text{Data}}$ High Low Output Level $\overline{\text{Data}}$ Amplitude Max Output Level $\overline{\text{Data}}$ offset Low Output Level $\overline{\text{Data}}$ Amplitude Min Output Level	1.35 V 1.8 V N/A 400 mV  1.35 V 1.8V N/A 400 mV		1.65 V 2.2 V -2.7 V 600 mV  1.65 V 2.2 V -2.7 V 600 mV
11-14	<b>Tracking Off</b> Data High Low Output Level Data Amplitude Max Output Level Data offset Low Output Level Data Amplitude Min Output Level  $\overline{\text{Data}}$ High Low Output Level $\overline{\text{Data}}$ Amplitude Max Output Level $\overline{\text{Data}}$ offset Low Output Level $\overline{\text{Data}}$ Amplitude Min Output Level	1.35 V 1.8 V N/A 400 mV  1.35 V 1.8V N/A 400 mV		1.65 V 2.2 V 2.7 V 600 mV  1.65 V 2.2 V 2.7 V 600 mV
11-15	Data Delay 1.5 Gb/s Data Delay 4.5 Gb/s Data Delay 9 Gb/s Data Delay 12 Gb/s	1 ns 1 Clk per 1 Clk per 1 Clk per		N/A N/A N/A N/A

**Performance Test Record, continued**

Page No.	Test Description	Result		
		Min	Actual	Max
11-17	PG Trigger CLK/32 PG Trigger CLK/8 PG Trigger output pattern	32 Clk per 8 Clk per 32 Clk per		32 Clk per 8 Clk per 32 Clk per
11-18	Subrate Clock offset High Output Level Subrate Clock Amplitude Max Output Level Subrate Clock offset Low Output Level Subrate Clock Amplitude Min Output Level	-100 mV 900 mV -1.7 V 400 mV		100 mV 1.1 V 1.3 V 600 mV
11-20	Subrate Data0 offset High Output Level Subrate Data0 Amplitude Max Output Level Subrate Data0 offset Low Output Level Subrate Data0 Amplitude Min Output Level  Subrate Data1 offset High Output Level Subrate Data1 Amplitude Max Output Level Subrate Data1 offset Low Output Level Subrate Data1 Amplitude Min Output Level	-100 mV 900 mV -1.7 V 400 mV  -100 mV 900 mV -1.7 V 400 mV		100 mV 1.1 V 1.3 V 600 mV  100 mV 1.1 V 1.3 V 600 mV
11-20	Subrate Data2 offset High Output Level Subrate Data2 Amplitude Max Output Level Subrate Data2 offset Low Output Level Subrate Data2 Amplitude Min Output Level  Subrate Data3 offset High Output Level Subrate Data3 Amplitude Max Output Level Subrate Data3 offset Low Output Level Subrate Data3 Amplitude Min Output Level	-100 mV 900 mV -1.7 V 400 mV  -100 mV 900 mV -1.7 V 400 mV		100 mV 1.1 V 1.3 V 600 mV  100 mV 1.1 V 1.3 V 600 mV
11-22	Auxiliary Input Pattern Alternates?	N/A		N/A
11-23	Error Inject	Single error Fixed error rate 1e <sup>-9</sup> Fixed error rate 1e <sup>-8</sup> Fixed error rate 1e <sup>-7</sup> Fixed error rate 1e <sup>-6</sup> Fixed error rate 1e <sup>-5</sup> Fixed error rate 1e <sup>-4</sup> Fixed error rate 1e <sup>-3</sup>  External Error Inject 2e <sup>-9</sup> External Error Inject 2e <sup>-8</sup> External Error Inject 2e <sup>-7</sup> External Error Inject 2e <sup>-6</sup> External Error Inject 2e <sup>-5</sup> External Error Inject 2e <sup>-4</sup> External Error Inject 2e <sup>-3</sup>	10 <sup>9</sup> 10 <sup>8</sup> 10 <sup>7</sup> 10 <sup>6</sup> 10 <sup>5</sup> 10 <sup>4</sup> 10 <sup>3</sup>  44.99e 10 <sup>8</sup> 44.99e 10 <sup>7</sup> 44.99e 10 <sup>6</sup> 44.99e 10 <sup>5</sup> 44.99e 10 <sup>4</sup> 44.99e 10 <sup>3</sup> 44.99e 10 <sup>2</sup>	10 <sup>9</sup> 10 <sup>8</sup> 10 <sup>7</sup> 10 <sup>6</sup> 10 <sup>5</sup> 10 <sup>4</sup> 10 <sup>3</sup>  5.01e10 <sup>8</sup> 5.01e10 <sup>7</sup> 5.01e10 <sup>6</sup> 5.01e10 <sup>5</sup> 5.01e10 <sup>4</sup> 5.01e10 <sup>3</sup> 5.01e10 <sup>2</sup>
11-25	Error Detector Clock Input Alarm	N/A		-4 dBm



**Performance Tests**  
**HP 70843 option UHF Line Final Test Data**

**Performance Test Record, continued**

Page No.	Test Description		Result		
			Min	Actual	Max
11-26	Error Detector Pattern Trigger Output	CLK/8 CLK/32 Pattern	8clk per 32clk per 16clk per		8clk per 32clk per 16clk per
11-27	Error Measurement		N/A		N/A
11-27	Error Output	Fixed Rate $1e10^{-3}$	$1e10^3$		$1e10^3$
11-28	Audible Error Output	Single Error Beep Err=Add $1e10^{-9}$ Err=Add $1e10^{-8}$ Err=Add $1e10^{-7}$ Err=Add $1e10^{-6}$ Err=Add $1e10^{-5}$ Err=Add $1e10^{-4}$ Err=Add $1e10^{-3}$	N/A N/A N/A N/A N/A N/A N/A N/A		N/A N/A N/A N/A N/A N/A N/A N/A
11-28	Audio Volume		1		15
11-28	Data 0/1 Threshold Test	0/1 Threshold Test (-250 mV) 0/1 Threshold Test (-3 V) 0/1 Threshold Test(500 mV)	-260 mV -3.1V 400 mV		-240 mV -2.9 V 600 mV
11-29	Clock/Data Align				
11-29	Data Input Sensitivity		N/A		50 mV
11-31	Format Floppy Disk		N/A		N/A
11-31	Load, edit and save current pattern to:	DISK PATT 5 DISK PATT 6 DISK PATT 7 DISK PATT 8 DISK PATT 9 DISK PATT 10 DISK PATT 11 DISK PATT 12	N/A N/A N/A N/A N/A N/A N/A N/A		N/A N/A N/A N/A N/A N/A N/A N/A
11-31	Patt. Verif	PRBS $2^{23}-1$ @ 100 Mb/s PRBS $2^7-1$ @ 100 Mb/s PRBS $2^{10}-1$ @ 100 Mb/s PRBS $2^{15}-1$ @ 100 Mb/s PRBS $2^{31}-1$ @ 100 Mb/s	N/A N/A N/A N/A N/A		N/A N/A N/A N/A N/A

**Performance Tests**  
**HP 70843 option UHF Line Final Test Data**

---

**Performance Test Record, continued**

Page No.	Test Description		Result		
			Min	Actual	Max
11-31	Patt. Verif.	PRBS 2^23-1@1Gb/s PRBS 2^7-1@1Gb/s PRBS 2^10-1@1Gb/s PRBS 2^15-1@1Gb/s PRBS 2^31-1@1Gb/s PRBS 2^23-1@4.5Gb/s PRBS 2^7-1@4.5Gb/s PRBS 2^10-1@4.5Gb/s PRBS 2^15-1@4.5Gb/s PRBS 2^31-1@4.5Gb/s	N/A N/A N/A N/A N/A N/A N/A N/A N/A N/A		N/A N/A N/A N/A N/A N/A N/A N/A N/A N/A
11-31	Patt. Verif.	PRBS 2^23-1@9Gb/s PRBS 2^7-1@9Gb/s PRBS 2^10-1@9Gb/s PRBS 2^15-1@9Gb/s PRBS 2^31-1@9Gb/s	N/A N/A N/A N/A N/A		N/A N/A N/A N/A N/A
11-31	Patt. Verif.	PRBS 2^23-1@12Gb/s PRBS 2^7-1@12Gb/s PRBS 2^10-1@12Gb/s PRBS 2^15-1@12Gb/s PRBS 2^31-1@12Gb/s	N/A N/A N/A N/A N/A		N/A N/A N/A N/A N/A
11-31	Patt. Verif.	DISKPATT 12@12Gb/s DISKPATT 11@12Gb/s DISKPATT 10@12Gb/s DISKPATT 9@12Gb/s DISKPATT 8@12Gb/s DISKPATT 7@12Gb/s DISKPATT 6@12Gb/s DISKPATT 5@12Gb/s	N/A N/A N/A N/A N/A N/A N/A N/A		N/A N/A N/A N/A N/A N/A N/A N/A
11-31	Residual Error Rate Test		N/A		N/A
11-32	Error Location Capture		N/A		N/A

**Performance Tests  
HP 70843 Line Final Test Data**

**HP 70843 Line Final Test Data**

**Calibration Data Sheet**

<b>Page No.</b>	<b>Parameter</b>	<b>Lower/Limit</b>	<b>Upper/Limit</b>	<b>Actual</b>	<b>Pass/Fail</b>
11-4	DATA risetime 2 Vpp	N/A	30 ps		
11-4	DATA falltime 2 Vpp	N/A	30 ps		
11-6	$\overline{\text{DATA}}$ risetime 2 Vpp	N/A	30 ps		
11-6	$\overline{\text{DATA}}$ falltime 2 Vpp	N/A	30 ps		
11-8	CLOCK risetime 2 Vpp	N/A	30 ps		
11-8	CLOCK falltime 2 Vpp	N/A	30 ps		
11-9	$\overline{\text{CLOCK}}$ risetime 2 Vpp	N/A	30 ps		
11-9	$\overline{\text{CLOCK}}$ falltime 2 Vpp	N/A	30 ps		
11-5	DATA jitter pp @ 10 GHz	N/A	20 ps		
11-7	$\overline{\text{DATA}}$ jitter pp @ 10 GHz	N/A	20 ps		
11-8	Adjacent bit-length	N/A	N/A		
11-29	DATA input sensitivity @ 10 GHz	N/A	100 mV		

**Calibration Data Sheet**

<b>Functional test - Test group</b>	<b>Pass/Fail</b>
CLOCK input tests	
DATA & $\overline{\text{DATA}}$ output range, amplitude & frequency	
CLOCK & $\overline{\text{CLOCK}}$ output range, amplitude & frequency	
Pattern Generator phase shift range	
Subrate output range	
Auxiliary & Error inputs, PG trigger output	
Back-back pattern tests	
Residual error rate tests	
Error Detector phase slicing range	
Error Detector phase shift range	
Gating Input, Errors & ED Trigger output	



---

## **Error Messages**

## **Introduction**

During operation of the HP 71612 Series error performance analyzer certain configurations, events and keystrokes are invalid and produce error messages.

The *Standard Commands for Programmable Instruments* (SCPI) splits errors into those with positive error numbers and those with negative numbers.

Positive ones are specific to this instrument. They are categorized into non-permanent and permanent errors. Permanent errors signify a lasting problem with the instrument that should be investigated. Non-permanent errors are generally associated with incorrect user settings. The following pages give a complete list of errors. A fuller description is given in cases where the displayed message needs further explanation.

Negative ones are not specific to this instrument and they are defined by SCPI. As such, they are not listed here.

**Error Messages**  
**Non-Permanent Errors**

---

**Non-Permanent Errors**

---

**Non-Permanent Errors**

<b>Error No.</b>	<b>Displayed Message</b>	<b>Description</b>
101	Invalid set option	An invalid set option was detected on an HP-IB set command.
102	Invalid query option	An invalid query option was detected on an HP-IB query command.
103	Already gating	The instrument cannot be commanded to start gating while it is already gating.
104	Already not gating	The instrument cannot be commanded to end gating while it is already not gating.
105	Not while gating	This command is not permitted while the instrument is gating.
106	Clock attenuator too large	Attempt to specify a value of "Ext Atten" for the CLOCK and CLOCK OUT/ which is out of range.
107	Keyboard locked	Commands that change the instrument's configuration are not permitted while the keyboard is locked.
109	Pattern length too short for Block BER	Block BER cannot be selected if the current pattern length is less than 32.
110	Window too small	The size of the window allocated on the HP 70004A Display is inadequate; a full size window is needed.
111	Conflicts with run of zeros	The zero-substitution pattern requested is incompatible with the current setting of the run of zeros.
112	Conflicts with zsub length	The run of zeros requested is incompatible with the current setting of the zero-substitution length.
113	Conflicts with data high level	The data amplitude requested is incompatible with the current setting of the data high level.
114	Conflicts with data amplitude	The data high level requested is incompatible with the current setting of the data amplitude.
115	Not enough room on User's Page	The item cannot be added to the User's Page because there is insufficient space remaining.
116	Clock freq exceeds maximum of option	The requested frequency setting is higher than the maximum for this instrument option.
117	Not when external controller connected	Cannot select an HP-IB printer to receive the logged output when there is already an external HP-IB controller already connected. Disconnect the controller.

**Error Messages**  
**Non-Permanent Errors**

---

**Non-Permanent Errors, continued**

<b>Error No.</b>	<b>Displayed Message</b>	<b>Description</b>
118	No ext controller connected to log to	An external controller is selected to receive the logged output, but there is not one connected. Connect an external controller or select a printer to receive the data.
120	Data attenuator too large	The instrument cannot produce the defined ECL levels with the current value of attenuator.
121	Slave not present	The command can be executed only if a slaved signal generator exists
122	Allowed only in manual gating	The command can be executed only if the instrument has manual gating mode selected.
123	Do not have system clock	The date or time cannot be set in this module as it is not the holder of the system date and time. Of all the modules in the system, the one with the lowest MS-IB address is the holder of the system date and time.
124	Cannot align data while gating	A Clock to Data alignment cannot be initiated while gating.
125	Cannot center data while gating	A 0/1 Threshold centering cannot be initiated while gating.
126	Cannot align data while centering	A Clock to Data alignment cannot be initiated while gating.
127	Cannot center data while aligning	A 0/1 threshold centering cannot be initiated while gating.
128	Allowed only when 0/1 threshold is manual	The 0/1 threshold must be set to manual before the manual threshold can be set.
401	Cursor position outside range	The requested cursor position is outside the legal range.
402	Invalid pattern length	The chosen length for the pattern cannot be generated by the instrument. The length must lie within the specified resolution.
403	Pattern length out of range	The pattern length is too large for the store.
407	Label too long	The pattern label exceeds the maximum length of 14.
408	Invalid pattern store	The pattern store number does not identify a valid store.
409	Straight patterns have no half B	An operation specific to an alternate pattern has been attempted on a straight pattern.



**Error Messages**  
**Non-Permanent Errors**

---

**Non-Permanent Errors, continued**

<b>Error No.</b>	<b>Displayed Message</b>	<b>Description</b>
411	Disk pattern header invalid	An error has been detected in the information within the file holding the pattern store data. The file may be corrupted.
414	Disk pattern store invalid	The index field in the file containing the pattern store data is set to an illegal value. The file may be corrupted.
415	Disk pattern type invalid	The pattern type field in the file containing the pattern store data is set to an illegal value. The file may be corrupted.
416	Disk pattern label invalid	The pattern label in the file containing the pattern store data contains an illegal character. The file may be corrupted.
417	Internal disk error	The pattern label in the file containing the pattern store data contains an illegal character. The file may be corrupted.
419	Directory overflow	Although there may be room on the media for the file, there is no room in the directory for another file name.
420	Disk file not found	There is no file corresponding to the pattern store on the disk.
421	End of pattern file error	Operation caused the end of file to be reached. No data left whilst reading, or space left when writing to a pattern store.
422	Disk full	The disk is full. There is not enough free space for the specified size of pattern store.
424	File open on disk	Operation not allowed on open file. May arise after changing the disk whilst an operation is in progress.
425	Disk not in drive	Disk changed or not in drive. Either there is no disk in the drive, or the eject button is pressed whilst the disk is being accessed.
427	Disk write protected	Attempting to change the contents of a disk with it's write-protect tab set. Saving to a pattern store on disk, deleting a pattern store from the disk, or formatting a disk all generate this error if the disk is write-protected.
428	Disk media uninitialized	Media not initialized. The disk must be formatted before it is used to store pattern information.
429	Disk data read error	Read data error. The media is physically or magnetically damaged, and the data cannot be read.
430	Disk check read error	Check read error. An error was detected when reading the data just written. The media is probably damaged.

**Error Messages**  
**Non-Permanent Errors**

---

**Non-Permanent Errors, continued**

<b>Error No.</b>	<b>Displayed Message</b>	<b>Description</b>
431	Corrupt disk	Disk may be corrupt.
435	Unable to reload edit buffer	During power-on, the user pattern memory could not be reloaded from the appropriate pattern store (the disk last used for the UPAT selection was not inserted at power-on).
439	Not allowed in manual gating	The action requested is not allowed while manual gating mode is selected.
440	Allowed only in repetitive gating	The action requested is allowed only while repetitive gating mode is selected.
441	Allowed only for HEX entry	The action requested is allowed only while HEX data entry is selected.
442	Allowed only when user's page selected	The action requested is allowed only while the User's Page is selected.
443	Allowed only when tracking disabled	The action requested is allowed only while the output tracking is disabled.
444	No pattern generator present	The action requested is not allowed because there is no pattern generator module
445	No error detector present	The action requested is not allowed because there is no error detector module.
446	Not allowed in divided clock mode	The action requested is not allowed when the trigger mode is set to divided clock.
447	Allowed only in divided clock mode	The action requested is allowed only when the trigger mode is set to divided clock.
448	Allowed only for pure PRBS patterns	The action requested is allowed only when the pattern is a pure, non-modified PRBS.
449	Not allowed for pure PRBS patterns	The action requested is not allowed when the pattern is a pure, non-modified PRBS
450	Allowed only in block BER mode	The action requested is allowed only when the error location Block BER mode is selected.
451	Not allowed in block BER mode	The action requested is not allowed when the error location Block BER mode is selected.
452	Not allowed in burst gating mode	The action requested is not allowed when the burst gating mode is selected.
453	Allowed only for zero sub patterns	The action requested is allowed only when there is a zero sub pattern selected.
454	Allowed only for mark density patterns	The action requested is allowed only when there is a mark density pattern selected.

**Error Messages**  
**Non-Permanent Errors**

---

**Non-Permanent Errors, continued**

<b>Error No.</b>	<b>Displayed Message</b>	<b>Description</b>
455	Allowed only for fixed error add mode	The action requested is allowed only when the fixed error-add mode is selected.
456	Not allowed with ac coupling	The action requested is not allowed when the output termination is set to ac coupling.
457	Allowed only with dc 0V coupling	The action requested is allowed only when the output termination is set to dc 0V coupling.
458	Valid hard key panel not installed	The hard key panel currently installed on the HP 70004A Display does not belong to this module. Either replace the panel with the correct one for this module, or use the Display's MENU key to bring up the top level menu.
459	Allowed only for alternate user patterns	The action requested is allowed only when there is an alternate user pattern selected.
460	Allowed only when alt pat mode is ALTERNATE	The action requested is allowed only when the alternate pattern switching mode is ALTERNATE.
461	Allowed only when alt pat mode is ONCE	The action requested is allowed only when the alternate pattern switching mode is ONCE.
462	Allowed only when alt pat source is USER	The action requested is allowed only when the alternate pattern switching source is USER.
463	70311 & 70312 have no control of amplitude	Control of the amplitude of the slaved signal generator is not allowed because the HP 70311 and HP 70312 have a fixed amplitude setting of +3 dBm.
464	All 1's trigger pattern not allowed	An all 1's trigger pattern is not allowed because this conflicts with the allowed PRBS patterns.
465	Allowed only when audio is on	The action requested is allowed only when the audio output is turned on.
466	Not allowed for alternate user patterns	The action requested is not allowed when the pattern is an alternate user pattern.
470	Non-volatile instr config memory error	The non-volatile instrument configuration has been lost during power-cycle (default configuration has been used). Contact Hewlett-Packard.
471	Non-volatile results memory error	The non-volatile results have been lost during a power-cycle. Contact Hewlett-Packard.
490	DATA OUT amplifier over current error	Incorrect external connection to DATA port or Pattern Generator h/w failure.
491	DATA OUT/ amplifier over current error	Incorrect external connection to DATA OUT/ port or Pattern Generator h/w failure.

**Error Messages**  
**Non-Permanent Errors**

---

**Non-Permanent Errors, continued**

<b>Error No.</b>	<b>Displayed Message</b>	<b>Description</b>
492	CLOCK OUT amplifier over current error	Incorrect external connection to CLOCK port or Pattern Generator h/w failure.
493	CLOCK OUT/ amplifier over current error	Incorrect external connection to CLOCK OUT/ port. or Pattern Generator h/w failure.
500	Update file format error	Incorrect or defective software update disk.
503	Invalid update file size	Defective software update disk. Contact Hewlett-Packard.
504	CRC error in update file	Defective software update disk. Contact Hewlett-Packard.
505	Error reading update file	Defective software update disk. Contact Hewlett-Packard.
510	Primary demux over-current activated	Incorrect external connection to DATA IN or error detector hardware failure. Contact Hewlett-Packard.
520	Subrate amplifier over current error	Incorrect external connection to SUBRATE CLOCK OUT or to 1 or more of the PARALLEL DATA OUTPUT ports or Pattern Generator hardware failure.
521	Subrate amplifier output error	Defective instrument software or calibration data. Contact Hewlett-Packard.
531	Failed to open logging to RS232 port	Defective instrument software. Contact Hewlett-Packard.
532	Logging port must be RS232	The RS232 logging baud rate cannot be selected unless the RS232 is selected as the logging port.
533	Already have external HP-IB controller	An attempt was made to initiate logging via the IEEE-488 HP-IB port in the system controller mode while another system controller is connected to that port.
534	BERT address conflicts with HP-IB printer	Change the IEEE-488 HP-IB on the rear panel of the BERT.
540	Logging already enabled	An attempt was made to initiate logging when it was already enabled.
541	Logging already disabled	An attempt was made to turn off logging when it was already turned off.
542	Not while logging enabled	An attempt was made to modify the logging configuration while logging was enabled.
543	Failed to turn on logging	Attempt was made to initiate logging failed. Contact Hewlett-Packard.

**Error Messages**  
**Permanent Errors**

---

**Non-Permanent Errors, continued**

<b>Error No.</b>	<b>Displayed Message</b>	<b>Description</b>
544	Failed to turn off logging	Attempt was made to turn off logging failed. Contact Hewlett-Packard.
545	Log buffer overflow	Logged data has overflowed the internal buffer because the instrument has not output the data at a sufficient rate to either the printer or external controller.
546	Too many alarm changes to log	Alarm logging has caused an overflow of the internal buffer. Stabilize the EdClkLs, DataLs and SyncLs flags.
550	Gating i/p asserted. Clk-data align aborted	The GATING INPUT has been asserted causing external disabling of bit error measurements which is incompatible with a clock to data input delay eye-centering operation.
551	Gating i/p asserted. 0/1 centering aborted	The GATING INPUT has been asserted causing external disabling of bit error measurements which is incompatible with a data input 0/1 threshold eye-centering operation.
900...999		All errors in this range are a consequence of firmware errors or compatibility. Contact Hewlett-Packard.

---

**Permanent Errors**

---

**Permanent Errors**

<b>Error No.</b>	<b>Displayed Message</b>	<b>Description</b>
130...359		All errors in this range are a consequence of firmware errors or compatibility, or hardware failure. Contact Hewlett-Packard.
360	Pgen gate array 0 cooling fan fault	*
361	Pgen gate array 1 cooling fan fault	*
362	Edet gate array 0 cooling fan fault	* Turn off the instrument and contact Hewlett-Packard.
363	Edet gate array 1 cooling fan fault	*
370...398		Invalid calibration data. Default data will be used with consequential impairment of input and output performance. Contact Hewlett-Packard.



---

## **Troubleshooting**

The aim of this chapter is to help you identify faults in your system.

---

## Entry Chart

All troubleshooting starts from the Entry Chart below:

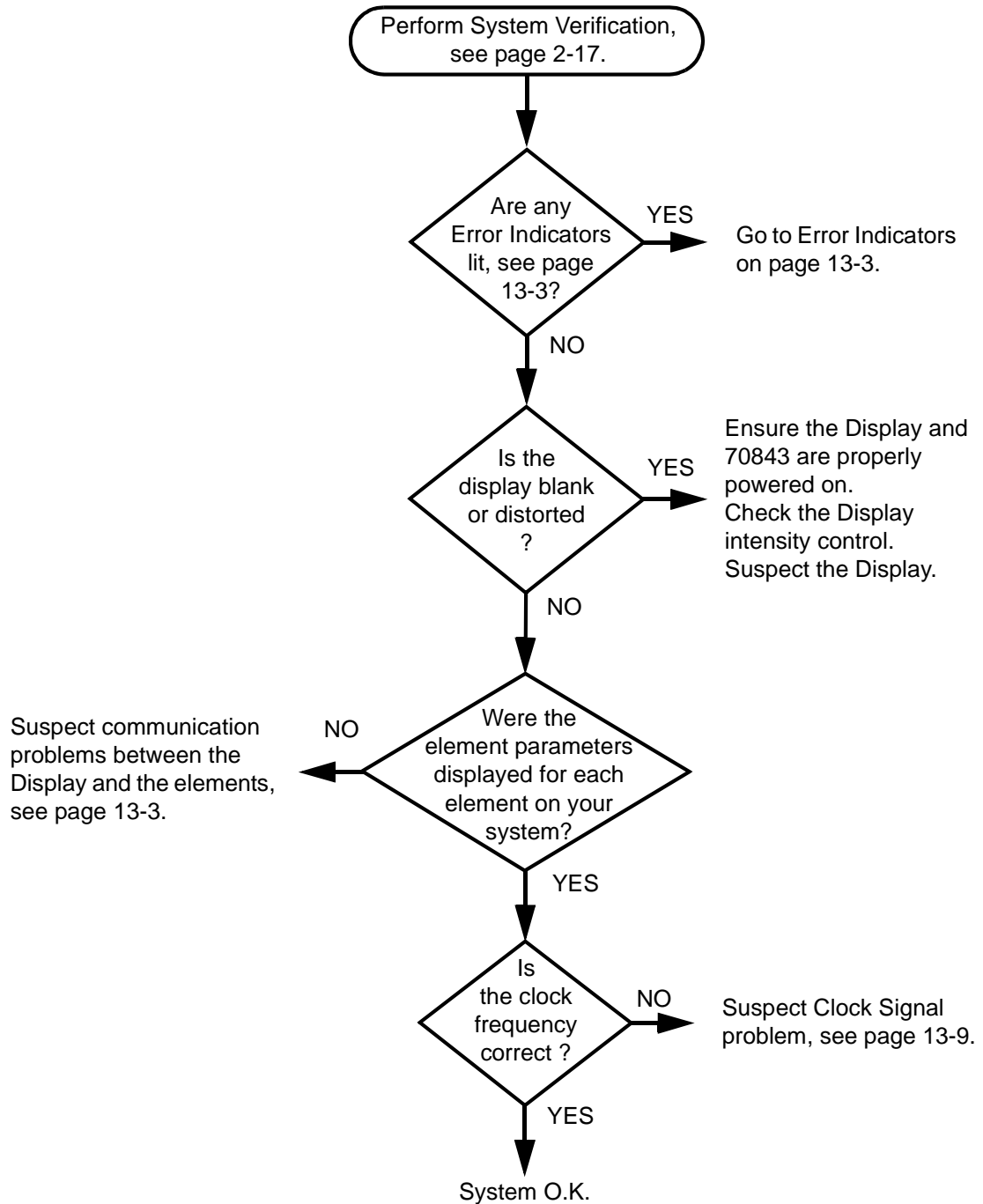



## System Indicators

Each element in the system has indicators to help with problem identification. The following indicators are fitted:

<b>Error Indicators</b>	These tell the user that there is a failure within the system.
<b>Error Messages</b>	These appear on the display and perform the same function as the <i>Error Indicators</i> .
<b>Active (ACT) Indicators</b>	These tell the user which element is currently active in the system.
<b>HP-IB Indicators</b>	These tell the user the current HP-IB status of each element.
<b>Gating Indicator</b>	This is fitted to the <i>Error Detector</i> module and indicates when a BER measurement is in progress.

**Troubleshooting  
System Indicators**

**Error Indicators**

The error indicators and associated troubleshooting information is contained in the following table. Troubleshoot the error indicators in the order given.

<b>Error Indicator</b>	<b>Location</b>	<b>Meaning</b>	<b>Page</b>
VOLT/TEMP	HP 70843	A low input ac voltage detected or an ambient temperature > 55°C.	13-5
E (flashing)	Display (CRT)	An HP-MSIB problem has been detected at power on. This may effect normal communication between elements (may effect <b>Error Reporting</b> ).	13-7
ERR (flashing)	Any element		
HP-MSIB	Display (front panel)	An HP-MSIB problem has been detected.	
FAULT	Clock Source	Element faulty - refer to <b>Clock Source</b> Service manual.	
E (steady)	Display (CRT)	An element or the display has detected an error.	13-8
ERR (steady)	Element or Clock Source	The element has an error condition.	
CLK LOSS	Pattern Generator or Error Detector	The element has not detected the incoming clock signal.	13-9
DATA LOSS	Error Detector	The element has not detected the incoming data over a 1 ms gating period.	13-9
SYNC LOSS	Error Detector	The element has been unable to synchronize to the incoming data pattern.	13-10
ERRORS	Error Detector	The element has detected <b>Bit Errors</b> in the incoming data pattern.	13-10

## Volt/Temp Troubleshooting

The VOLT/TEMP indicator on the HP 70843 is lit when one of the following conditions occur:

- A low line voltage is applied to the HP 70843.
- The temperature inside the HP 70843 is  $> 55^{\circ}\text{C}$ .

Use the following procedure to determine the cause of the fault:

1. Power down the system and disconnect the mains power cable from the HP 70843.
2. Check that the line input voltage is within specification.

---

**NOTE** If the voltage increases to within the normal operating range, the HP 70843 will restart itself.

---

If the input line voltage is correct, suspect excessive ambient temperature inside the HP 70843.

3. Check that the fan is operating correctly by checking the air flow at the fan-intake openings.

---

**NOTE** It is recommended that the fan filters be regularly cleaned, as a build up of dust on the filters will reduce the airflow into the HP 70843.

If the temperature decreases to within the normal operating range, the HP 70843 will restart itself.

---

If all the above are good then the HP 70843 is faulty.

## HP-MSIB Troubleshooting

An HP-MSIB failure exists if any of the following indicators are lit:

- E (flashing) on the display.
- ERR (flashing) on HP 70843.
- HP-MSIB lit on the Display front panel.

The flashing *E* and *ERR* only occur at power on. When these occur normal communication between the Display and other elements in the system may be prevented. The cause of this failure must be found before any predictable system operation can take place.

The possible causes of an HP-MSIB failure are as follows:

- Display, HP 70843 or Clock Source not powered on.
- Poor HP-MSIB cable connection or faulty cable.
- Faulty Display.
- Faulty HP 70843.
- Faulty Clock Source

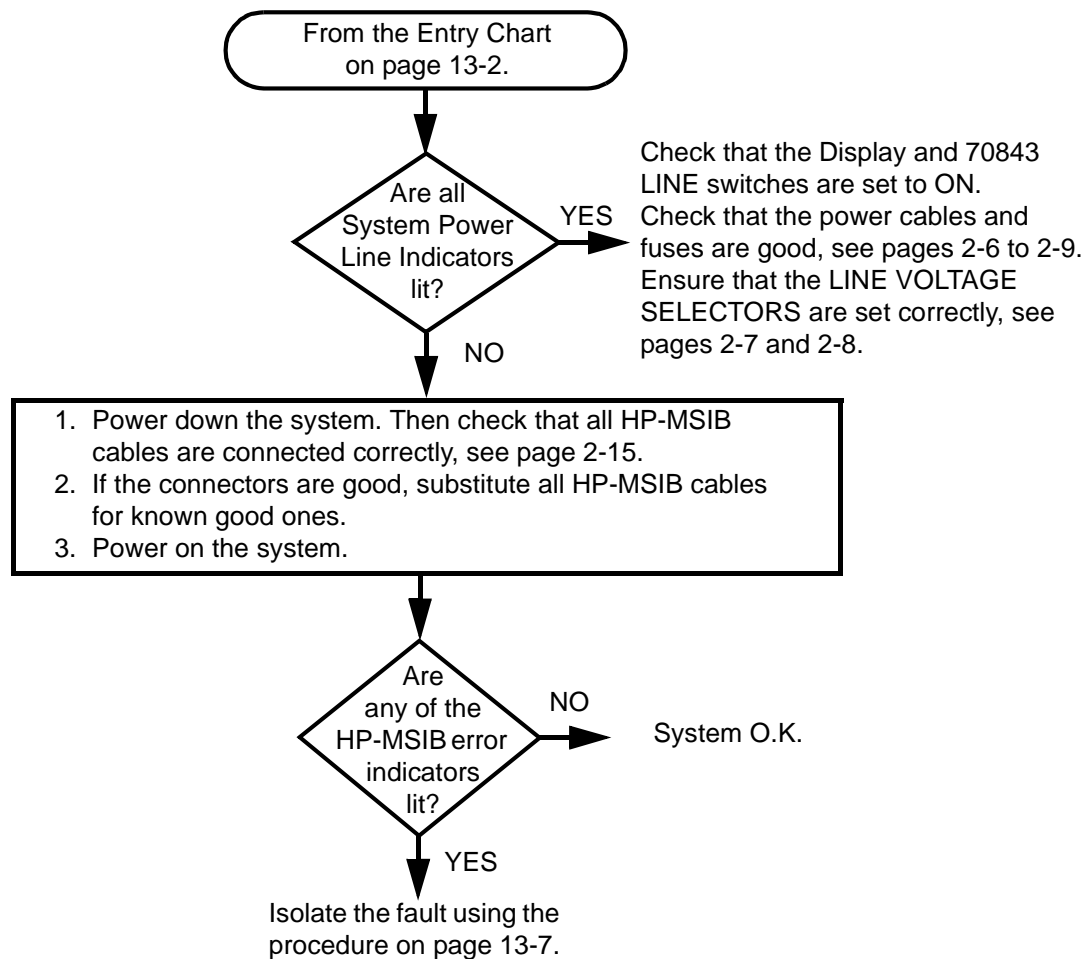

## Troubleshooting

### HP-MSIB Troubleshooting

Use the following procedure to troubleshoot all HP-MSIB error indicators:

1. Isolate all elements in your system as follows:
  - i. Power down your system.
  - ii. Disconnect all HP-MSIB cables.
  - iii. Remove the Clock Source from the Display.
2. Check the Display as follows:
  - i. Power on the Display.
  - ii. Is there an E (flashing or steady) on the display?  
*If YES, then the Display is faulty.*  
*If NO, power down the Display then go to step iii.*
  - iii. Connect a known good HP-MSIB cable between the **IN** and **OUT HP-MSIB** ports on the rear panel of the Display, then power on.
  - iv. Is there an E (flashing or steady) on the display?  
*If YES, then the Display is faulty.*  
*If NO, power down the Display, remove the HP-MSIB cable, then go to step 3*
3. Check the Clock Source as follows:
  - i. Plug a Clock Source into the Display, then power-on.
  - ii. Is there an E flashing on the Display or ERR flashing on the Clock Source?  
*If YES, then the Clock Source is faulty.*
4. Check the HP 70843 as follows:
  - i. Connect known good HP-MSIB cables between the **IN** and **OUT HP-MSIB** ports on the rear panel of the Display and HP 70843, then power on.
  - ii. Is there an E (flashing or steady) on the display, or is the **HP-MSIB** or **I/O CHECK** indicator lit?  
*If any error indicator is lit, check that the Display and HP 70843 are properly powered on and that the HP-MSIB cabling is correct. If these are good, and E is still flashing on the display then the HP 70843 is faulty.*

## MMS Error Messages

MMS error messages are available when a steady **E** is displayed or a steady **ERR** indicator is lit. MMS error messages break down into two groups, a general summary of each is given below:

<b>Instrument Specific Errors</b>	These error messages are specific to the HP 71612 Series and are positive numbers. They are divided into permanent and non-permanent fault conditions, see Chapter 12.
<b>Standard Commands for Programming Instruments (SCPI)</b>	These error messages apply to any Modular Measurement System and are negative numbers. They are divided into three groups; Command Errors, Execute Errors and Query Errors.

Error messages appear automatically at the bottom of the display or are accessed through the **Error Reporting** function on the display.

### Error Reporting

When an **E** appears on the display or an **ERR** indicator is lit and an error message is not automatically displayed, use the following procedure to access the **Error Reporting** function on the display:

1. Press the **DISPLAY** key.
2. Press the **REPORT ERRORS** softkey. If more than one element has reported errors, use the **MORE ERRORS** softkey. See Chapter 12, **Error Messages**.

When errors are reported by a master, the model number and HP-MSIB address of the element that generated the error are displayed.

---

**NOTE** After the errors have been read they are cleared from the system memory (except for permanent errors).

---

## Clock Loss Troubleshooting

If the clock frequency shown on the display is incorrect or if the **CLK LOSS** indicator is lit on either the Error Detector or Pattern Generator, suspect that one of the following is faulty:

- Clock Source module
- Display.

---

**NOTE** The **CLK LOSS** indicator will be lit if the clock signal is typically <-10 dBm.

---

## Clock Source Output

Access the Clock Source setup on the Display, check that the Clock Source Output is set to ON. Check that the frequency of the Clock source has been set within the range of the system, 1 GHz to 12 GHz for HP 71612 option UHx systems and 100 MHz to 12 GHz for the HP 71612 option UKB system. If correct, use an Oscilloscope or Power Meter to check the output level is >-10 dBm. If good, the Clock Source is good.

---

## Data Loss Troubleshooting

The **DATA LOSS** indicator is lit on the Error Detector when no data transitions have been detected over a 1 ms period. Normally, if there is a loss of input signal the **SYNCH** and **ERRORS** indicators will be lit. A loss of clock signal may also cause the **DATA LOSS** indicator to light, see **CLK LOSS Troubleshooting**.

To troubleshoot the systems first check the data being applied to the **Error Detector** and use known good cables - if still faulty then suspect the Error Detector.

---

**NOTE** The Error Detector **DATA IN** port is very sensitive and will trigger on background noise.

---

## Sync Loss and Errors Troubleshooting

If either of these indicators is lit, check that the Error Performance Analyzer verification procedure has been performed correctly. If good, suspect clock or data cabling between elements or a fault in the Pattern Generator or Error Detector.

---

## Communication Troubleshooting

If you are unable to access elements in your system through the Display - no communication between the Display and the elements - and there are no error indicators lit, use the following procedure to isolate the fault:

1. Check all elements have been set to valid HP-MSIB addresses.
  2. Isolate all elements in your system as follows:
    - i. Power down your system.
    - ii. Disconnect all HP-MSIB cables.
    - iii. Remove the Clock Source from the Display.
  3. Check that the Display can access all 31 addresses on row 0 as follows:
    - i. Power on the Display.
    - ii. Press **DISPLAY** and **Address Map**.
    - iii. Use the front panel control knob to scroll the green rectangle (on the display) along the 31 addresses on row 0.  
*If a red rectangle appears, the Display is faulty.*  
*If you can access the addresses, the Display is good. Power down the Display then go to step 4.*
  4. Check the Clock Source as follows:
    - i. Plug a Clock Source into the Display.
    - ii. Power on the Display.
    - iii. Check that the Display can access all 31 addresses on row 0, use the procedure in step 2.  
*If a red rectangle appears, the Clock Source is faulty.*  
*If you can access the addresses, the product number will be visible.*
  5. Check the HP 70843 as follows:
    - i. Connect known good HP-MSIB cables between the HP-MSIB IN and OUT ports on the rear panel of the Display and HP 70843.
    - ii. Power on the Display and HP 70843.
    - iii. Check the Display can access all 31 addresses on row 0, use the procedure in step 2.  
*If a red rectangle appears, the HP 70843 is faulty.*  
*If you can access the addresses, the HP 70843 is good.*
-



---

**Appendix A:  
Measurement Definitions**

## Measurement Definitions

Measurement definitions for the HP 71612A Series error performance analyzer are given in this appendix.

### Error Measurements

The error detector counts bit errors by comparing the incoming data bit-by-bit with the internally-generated reference pattern. Error count and ratio are calculated for three types of errors: errored ones, errored zeros and all logic errors. All measurements run during the gating periods as described with the exception of Delta Error Count and Delta Error Ratio. These measurements run continuously to facilitate user adjustments for minimizing errors.

#### Error Count

The total number of errors during the gating period.

#### Delta Error Count

The number of errors in successive decisecond intervals.

#### Error Ratio

The ratio of counted errors to the number of bits in the selected gating period.

#### Delta Error Ratio

The ratio of counted errors to the number of bits in successive decisecond intervals.

#### Errored Intervals

Time intervals during which one or more errors occurred. These intervals are errored seconds, deciseconds, centiseconds or milliseconds.

#### Error Free Intervals

Time intervals of seconds, deciseconds, centiseconds or milliseconds, during which no errors occurred.

### Error Analysis

The error analysis is based on CCITT Rec G.821 and is derived from the bit error results.

#### % Unavailability

The error ratio is calculated over 1 second timed intervals during the gating period. An unavailable period begins when the error ratio is worse than  $1 \times 10^{-3}$  for 10 consecutive seconds. These 10 seconds are considered part of the unavailable time. The unavailable

## Appendix A Measurement Definitions

period ends when the error ratio is better than  $1 \times 10^{-3}$  for 10 consecutive seconds. These 10 seconds are considered part of the available time. % Unavailability is the ratio of the unavailable seconds to the total gating period expressed as a percentage.

### **% Availability**

The ratio of the available seconds to the total gating period expressed as a percentage.

### **% Errored Seconds**

The ratio of the errored seconds in the available time to the total number of seconds in the available time, expressed as a percentage.

### **% Severely Errored Seconds**

The ratio of the total number of available seconds with an error ratio worse than  $1 \times 10^{-3}$  to the total number of available seconds, expressed as a percentage.

### **% Degraded Minutes**

Severely errored seconds are discarded from the available time and the remaining seconds are grouped into blocks of 60 seconds. Blocks which have an error ratio worse than  $1 \times 10^{-6}$  are called Degraded Minutes and % Degraded Minutes is the ratio of the total number of degraded minutes to the total number of 60 second blocks in the available time expressed as a percentage. Incomplete blocks of less than 60 seconds are treated as complete blocks of 60 seconds.

### **Power Loss Seconds**

Displayed as the number of seconds the error detector is not able to make measurements during a gating period owing to ac-power loss. The gating continues to the end of the selected period following restoration of power.

### **Sync-loss Seconds**

Displayed as the number of seconds the error detector loses pattern synchronization during a gating period.

### **Error Location Analysis (Option UHJ instruments)**

Error location is explained in Chapter 4, *Operating Features and Specifications*.



---

**Appendix B:  
Operating Notes**

---

## Setting Error Detector Sync Thresholds

### Introduction

The following paragraphs provide information on how to select the correct sync threshold for the current pattern. Failure to set the correct sync threshold may result in incorrect synchronization, which may cause errors or clock-to-data alignment failure. Sync threshold is setup using the **sync & audio** hardkey, then selecting a threshold from the available range of softkeys.

### Setting Sync Thresholds

To obtain accurate results you must choose a sync threshold which results in optimum alignment for the current pattern.

For any pattern other than a PRBS pattern, the error rate caused by non-alignment with the incoming data is dependent on the data pattern. Here the sync threshold should be chosen so that only EXACT pattern alignment results in the error detector gaining sync. For example, consider a pattern of 1000 ones and 1000 zeros as shown in the following figure. With *reference alignment 1* the patterns are totally out of phase and the error rate is 100%, but as the reference moves closer to optimum alignment the error rate drops gradually to zero. For exact alignment, the sync threshold must be set lower than the error rate caused by a 1 bit misalignment, in this case 1E03.

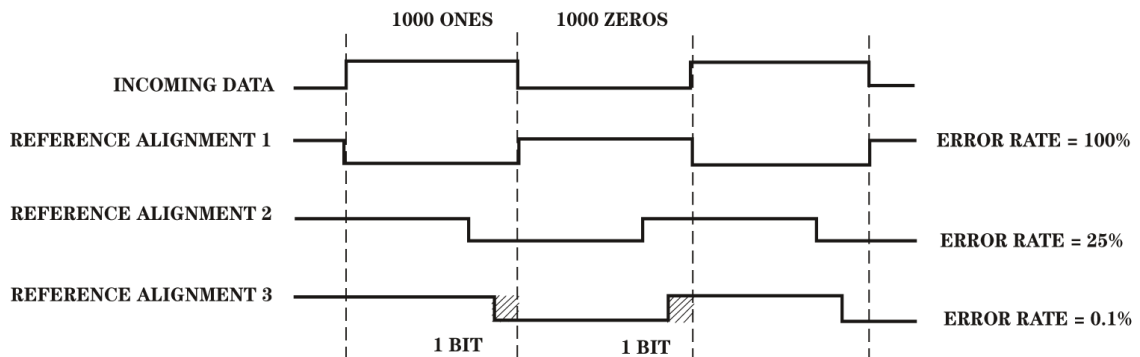

Figure B-1 Error rates due to pattern misalignment

In the general case, for an  $n$  bit pattern length the sync threshold should be set lower than  $2/n$  if optimum alignment is to be achieved.

### Clock-to-Data Alignment Failure

If you are experiencing a failure or intermittent failure when you perform clock-to-data alignment on a User Pattern, try setting the eye edge threshold to a new value, and retry

## Appendix B Pattern Generation

clock-to-data alignment. To select a new eye edge threshold press the **sync & audio** hardkey then select **EYE EDG THRSHL** and enter a new eye edge threshold using the numeric keypad.

---

### NOTE

On RAM based (USER) patterns the error detector may gain sync at a point in the pattern where the criteria for synchronization (set by the Sync Threshold) is met; but is not the correct point where the internally generated reference pattern and the data input pattern match. When the error detector gains sync incorrectly errors occur and clock-to-data alignment may fail. If this occurs reset the eye edge threshold to a lower value and recheck the error rate and clock-to-data alignment.

---

---

### NOTE

For most RAM based patterns synchronization should occur in less than 3 seconds. However synchronization times are dependent on pattern length, pattern content and clock frequency and will increase as pattern length increases or clock frequency decreases. For very long patterns (for example 8 Mb/s) times could be of a minute or more.

---

---

## Pattern Generation

### Introduction

- Patterns in the HP 71612 pattern generator or error detector are generated either from hardware registers or from patterns stored in random access memory (RAM).
- PRBS patterns  $2^7-1$ ,  $2^{10}-1$ ,  $2^{15}-1$ ,  $2^{23}-1$ ,  $2^{31}-1$  are generated from hardware registers. Patterns are generated 32-wide and so a trigger output is produced once for every 32 repetitions of the serial pattern.
- All other patterns are generated from RAM.

The RAM in the instrument is 256 bits wide, this controls how patterns are stored and in turn how some features work.

Within the instrument, patterns are replicated in RAM until they fit an exact multiple of 256 bits. Patterns which are already a multiple of 256 bits need no replication, other patterns are replicated as many as 256 times. For example, all odd-length patterns are replicated 256 times. The replication controls the way a number of instrument features operate.

- Trigger rate
- Pattern granularity
- Bit and block BER measurement sampling rate

## Pattern Editor and Substrate Data

If you select a mark density, zerosub or user pattern (all RAM patterns) using the pattern editor, the pattern present at the parallel data out ports depends on pattern length and the trigger bit position.

The following paragraphs explain how pattern length and trigger bit position effect the substrate data patterns output from the parallel data ports.

### Pattern Lengths Divisible By Four

On a pattern whose length is a multiple of four, and with the trigger bit position set to bit 0, the substrate channel correspondence is as follows:

<b>Pattern</b>		<b>x</b>	<b>x</b>	<b>x</b>	<b>x</b>	<b>x</b>	<b>x</b>	<b>x</b>	<b>x</b>	<b>x</b>
<b>Substrate Channel</b>		<b>D0</b>	<b>D1</b>	<b>D2</b>	<b>D3</b>	<b>D0</b>	<b>D1</b>	<b>D2</b>	<b>D3</b>	<b>D0</b>

The following example shows a 20-bit pattern with the pattern trigger bit position set to bit 0.

		<b>1</b>	<b>1</b>	<b>1</b>	<b>1</b>	<b>0</b>	<b>0</b>	<b>0</b>	<b>0</b>	<b>1</b>	<b>0</b>	<b>0</b>	<b>0</b>	<b>0</b>	<b>1</b>	<b>0</b>	<b>0</b>	<b>1</b>	<b>0</b>	<b>1</b>	<b>0</b>	
<b>D0</b>		<b>1</b>				<b>0</b>				<b>1</b>					<b>0</b>				<b>1</b>			
<b>D1</b>			<b>1</b>				<b>0</b>				<b>0</b>				<b>1</b>					<b>0</b>		
<b>D2</b>				<b>1</b>				<b>0</b>				<b>0</b>				<b>0</b>					<b>1</b>	
<b>D3</b>					<b>1</b>				<b>0</b>				<b>0</b>				<b>0</b>					<b>0</b>

### Pattern Lengths Not Divisible By Four

To determine the pattern present at the parallel data out ports, the pattern length must be multiplied up until it is a multiple of 4 (some patterns as much as 256 times) and then every fourth bit assigned to D0 to D3. All odd-length patterns are replicated 256 times.

### Substrate Output Pattern Change with Trigger Bit Position

Note that changing the trigger bit position changes the substrate channel correspondence and hence the pattern output from the parallel data out ports. For example, if the trigger position is set to bit 1 then the output is as follows:

<b>Pattern</b>		<b>x</b>	<b>x</b>	<b>x</b>	<b>x</b>	<b>x</b>	<b>x</b>	<b>x</b>	<b>x</b>	<b>x</b>
<b>Substrate Channel</b>		<b>D3</b>	<b>D0</b>	<b>D1</b>	<b>D2</b>	<b>D3</b>	<b>D0</b>	<b>D1</b>	<b>D2</b>	<b>D3</b>



## Symbols

#COPIES TO LOAD, softkey 8-10  
% Availability A-3  
% Degraded Minutes A-3  
% Errored Seconds A-3  
% Severely Errored Seconds A-3  
% Unavailability A-2

## Numerics

0/1 MAN THRSBLD, softkey 7-30  
0/1 Manual Threshold, softkey 11-28,  
11-30  
0/1 THR AUTO, softkey 2-17  
0/1 THR AUTOMAN, softkey 5-9, 7-30  
0/1 THR CENTER, softkey 2-17, 4-18, 5-9,  
7-31  
0/1 Threshold AUTO/MAN, softkey 11-28  
0/1 Threshold Center, softkey 11-30  
0/1 Threshold Centering 4-18  
0/1 THRSBLD, softkey 7-25  
1, hardkey 7-8  
1/2, softkey 8-9  
1/4, softkey 8-9  
1/8, 1/4, 1/2, softkey 7-5  
1/8, softkey 8-9  
1e-1 to 1e-8, softkey 7-32  
1e-3, softkey 11-28  
1e-8, softkey 11-28  
1e-9, softkey 11-24, 11-28  
2<sup>10</sup> MARKDEN, softkey 7-5  
2<sup>10</sup> PRBS, softkey 8-15  
2<sup>10</sup> ZEROSUB, softkey 7-4  
2<sup>10</sup>, softkey 8-9, 8-10  
2<sup>10</sup>-1 PRBS, softkey 7-4  
2<sup>11</sup> MARKDEN, softkey 7-5  
2<sup>11</sup> ZEROSUB, softkey 7-4  
2<sup>11</sup>, softkey 8-9, 8-10  
2<sup>13</sup> MARKDEN, softkey 7-5  
2<sup>13</sup> prbs, softkey 5-11, 11-32  
2<sup>13</sup> ZEROSUB, softkey 7-4  
2<sup>13</sup>, softkey 8-9, 8-10  
2<sup>15</sup>-1 PRBS, softkey 7-4

2<sup>23</sup>-1 PRBS, softkey 7-4  
2<sup>31</sup>-1 PRBS, softkey 7-4  
2<sup>7</sup> MARKDEN, softkey 7-5, 11-17  
2<sup>7</sup> ZEROSUB, softkey 7-4  
2<sup>7</sup>, softkey 8-9, 8-10  
2<sup>7</sup>-1 PRBS, softkey 7-4  
2<sup>7</sup>-1, softkey 11-26  
3/4, 7/8, softkey 7-5  
3/4, softkey 8-9  
7/8, softkey 8-9  
9, hardkey 7-8

## A

A, softkey 7-8  
A-B, softkey 7-17  
ABORT ALIGN, softkey 7-31  
Accessories 2-14  
Accessories Supplied 1-2, 1-8  
Accessories, recommended 1-8  
Accessories, Static-safe 1-12  
Active (ACT) Indicators 13-3  
Additional System Options 3-3  
Address Map, softkey 2-12, 13-10  
Adjacent bit-length test 11-8  
ALT PAT ALT ONCE, softkey 7-10, 8-13  
ALT PAT AUX USR, softkey 7-10, 8-13  
ALT PAT HALF AB, softkey 7-10  
ALT PAT ON OFF, softkey 5-11, 7-9  
ALT PAT ON, softkey 7-9  
ALT PAT ONCE B, softkey 7-10  
ALT PAT, softkey 7-9  
ALT, softkey 4-11, 7-10  
Alternate Pattern Control 7-9  
Alternate Patterns 4-4, 4-10, 8-12  
ALTPAT ALTONCE, softkey 4-11  
ALTPAT AUX USR, softkey 4-11, 5-11,  
11-32  
ALTPAT HALF AB, softkey 5-11, 11-32  
ALTPATT ON OFF, softkey 8-13, 11-32  
ALTPATT, softkey 8-14  
Audible Error Output 11-28  
Audible Output 4-24  
AUDIO ON OFF, softkey 7-32, 11-28

## Index - Operating Manual

- AUDIO ON/OFF, hardkey 11-27
- AUDIO SYNC LS, softkey 7-32
- AUDIO SYNCLS, softkey 4-25, 7-25
- AUDIO VOLUME, softkey 7-32, 11-28
- AUTO, softkey 5-9, 7-30, 11-28
- Auto-alignment 4-17-4-18
- Automatic 0/1 Threshold Center 4-18
- Automatic Clock-to-Data Alignment 4-17
- AUX, softkey 4-11, 7-10, 8-13
- Auxiliary Input 4-10
- Auxiliary Input (Alternate word switchover) 11-22
- AVAILBL (%), softkey 7-29
  
- B**
- B, softkey 5-11, 11-32
- Basic Editor Operation 8-2
- Bench Operation 2-13
- BIG DELTA C, softkey 7-29
- BIG DELTA R, softkey 7-29
- BIG ELAPSED, softkey 7-29
- BIG ERR CNT, softkey 7-29
- BIG ERR RAT, softkey 7-29
- BIG results USER'S PAGE menu 7-29
- BIG results, softkey 7-27
- BINARY HEX, softkey 7-8
- Bit BER 4-20
- BIT COUNT, softkey 7-26
- BIT ERR ADDRESS, softkey 7-25, 7-27, 7-35
- BIT ERR CNT, softkey 7-28
- BIT ERR RAT, softkey 7-28
- Block BER 4-21
- BLOCK BER, softkey 7-35
- BLOCK LENGTH, softkey 7-25, 7-35
- block load, softkey 8-17
- block save, softkey 8-17
- BLOCK START, softkey 7-25, 7-35
- blue softkeys/window 5-3, 7-2
- Build User Page Big Results Menu Map 6-22
- Build User Page Clock Output Menu Map 6-17
- Build User Page Data Output Menu Map 6-17
- Build User Page Error Add Substrate Data/Clock Menu Map 6-18
- Build User Page Eye Results Menu Map 6-22
- Build User Page G.821 Results Menu Map 6-21
- Build User Page Gating and Error Location Menu Map 6-19
- Build User Page Input and Sync Menu Map 6-18
- Build User Page Interval Results Menu Map 6-21
- Build User Page Logging Menu Map 6-19
- Build User Page Main Results Menu Map 6-20
- Build User Page Menu Map 6-16
- Build User Page Other Results Menu Map 6-20
- Build User Page Pattern & Trigger Menu Map 6-16
- Build User-Page Softkey Menu 7-23
- build usr-pge, softkey 4-25, 4-26, 7-20, 7-23
- Burst gating 4-23
- BURST GATING, softkey 7-34
  
- C**
- C/TRACK, softkey 11-11, 11-12
- C/TRCK ON OFF, softkey 7-14, 11-12
- Cabinet Cleaning 1-13
- Calibration Data Sheet 11-37
- Calibration Interval 4-2
- cancel label, softkey 7-8
- cancel load, softkey 8-9
- CAPTURE ERROR, softkey 4-21, 5-11, 7-35, 11-32
- Carrying the HP 70843 1-12
- CENTER DEL RAT, softkey 7-29
- CENTER FREQ, softkey 7-29
- CENTER THRSHL, softkey 7-29
- Choosing a Pattern 8-4

## Index - Operating Manual

- CLEAR LABEL, softkey 7-8
  - CLEAR USR-PGE, softkey 7-20, 7-23
  - CLK DAT, hardkey 11-30
  - CLK I/P TERM, softkey 7-25
  - CLK O/P AMPLTD, softkey 7-24
  - CLK O/P HI-LEVL, softkey 7-24
  - CLK O/P TERM, softkey 7-24
  - CLK TRM 0V -2V, softkey 7-31
  - CLK, softkey 11-11, 11-26
  - CLK-DAT ALIGN, softkey 2-17, 5-9, 7-31, 11-29
  - Clock (Inverted) Falltime 11-9
  - Clock (Inverted) Out Amplitude and Frequency 11-11
  - Clock (Inverted) Risetime 11-9
  - CLOCK AMPLTD, softkey 7-13
  - Clock ampltd, softkey 11-12
  - Clock and Inverted Clock Outputs 4-8
  - CLOCK ECL, softkey 7-13
  - Clock Falltime 11-8
  - clock Hi-level, softkey 11-12
  - CLOCK HI-LEVL, softkey 7-13
  - Clock Input 4-5
  - Clock Input (error detector) 4-13
  - Clock Input Level Alarm 11-25
  - Clock Input Minimum Level Alarm 11-10
  - Clock Loss Troubleshooting 13-9
  - Clock Out Amplitude and Frequency 11-11
  - Clock Output Menu 7-13
  - Clock Output Menu Map 6-9
  - clock output, hardkey 4-8, 7-13, 11-4, 11-11, 11-12, 11-31
  - clock output, softkey 7-13, 11-12
  - Clock Outputs - Amplitude/High-Level 4-7, 4-8
  - Clock Risetime 11-8
  - Clock Source Output 13-9
  - CLOCK/ AMPLTD, softkey 7-13
  - CLOCK/ HI-LEVL, softkey 7-13
  - Clock/Data Align 4-17, 11-29, B-2
  - Clock-to-Data Alignment Failure B-2
  - Communication Troubleshooting 13-10
  - configuration key 7-2
  - Configurations 3-2
  - Cooling Considerations 2-5
  - CURRENT PATT, softkey 8-5
  - CURRENT PATTERN, softkey 7-6, 8-3, 8-16
- D**
- D/TRACK, softkey 11-13, 11-14
  - D/TRCK ON OFF, softkey 7-12
  - DAT I/P DELAY, softkey 4-17, 7-25, 7-30
  - DAT I/P POLRITY, softkey 7-25
  - DAT I/P TERM, softkey 7-25
  - DAT O/P AMPLTD, softkey 7-24
  - DAT O/P CONTROL, softkey 7-24
  - DAT O/P DELAY, softkey 7-24
  - DAT O/P HI-LEVL, softkey 7-24
  - DAT O/P POLRITY, softkey 7-24
  - DAT O/P TERM, softkey 7-24
  - DAT POL NORMINV, softkey 7-12, 7-30
  - DAT TRM 0V -2V, softkey 7-31
  - Data & Clock Output USER'S PAGE menus 7-24
  - Data (Inverted) Falltime 11-6
  - Data (Inverted) Jitter 11-7
  - Data (Inverted) Out Amplitude 11-13
  - Data (Inverted) Risetime 11-6
  - Data 0/1 Threshold Auto/Manual Test 11-28
  - Data Amplitude, softkey 11-30
  - DATA AMPLTD, softkey 7-11
  - Data ampltd, softkey 11-14
  - Data and Inverted Data Outputs 4-6
  - Data Delay 4-6, 11-15
  - DATA DELAY, softkey 7-12, 11-15, 11-29
  - DATA ECL, softkey 7-12
  - Data Falltime 11-4
  - Data Hi-level, softkey 11-14
  - DATA HI-LEVL, softkey 7-12
  - Data I/P Delay, softkey 7-30
  - Data Input 4-14
  - Data Input 0/1 Threshold 4-18
  - Data Input Delay 4-14, 11-29

## Index - Operating Manual

- Data Input Sensitivity 4-14, 11-29
- Data Jitter 11-5
- Data Logging 10-1–10-8
- Data Loss Troubleshooting 13-9
- DATA ON OFF, softkey 7-12
- Data Output Inhibit (Gating mode) 4-11
- Data Output Menu 7-11
- Data Output Menu Map 6-8
- data output, hardkey 4-6, 7-3, 7-11, 11-4, 11-13, 11-14, 11-15, 11-28, 11-29, 11-30
- data output, softkey 7-11
- Data Outputs - Amplitude/High-Level 4-6, 4-7
- Data Risetime 11-4
- DATA X-OVER, softkey 7-12, 7-13, 7-24
- DATA/ AMPLTD, softkey 7-11
- DATA/ HI-LEVL, softkey 7-12
- DATA/ ON OFF, softkey 7-12
- DATA/ TRACK, softkey 7-24
- DATA/ X-OVER, softkey 7-13
- Define, Edit and Store User Defined Patterns 8-2
- DEGRAD MINS(%), softkey 7-29
- Delete a Block of Data 8-12
- DELETE BIT, softkey 7-7, 8-7
- DELETE BLOCK, softkey 8-12
- delete diskpat, softkey 7-9, 8-16
- DELETE, softkey 7-8
- DELTA BIT CNT, softkey 7-28
- DELTA BIT RAT, softkey 7-28
- DELTA COUNT, softkey 7-27
- Delta Error Count A-2
- Delta Error Ratio A-2
- DELTA RATIO, softkey 7-27
- Demonstrate Capture Error 5-11
- Disk Format of String 8-19
- Disk Format of Unsigned Integer 8-19
- Disk Operation 8-16
- Disk Organization 8-17
- DISK PATT 5 to 12, softkey 8-8
- DISK PATT, softkey 7-6, 8-5, 8-6, 8-10, 8-11, 8-12, 8-13, 8-15
- Disk User Menu Map 6-6
- disk Utils 7-9
- Disk Utils Menu Map 6-6
- disk utils, softkey 7-9, 8-16, 11-31
- Disk-Based File Catalog 8-4
- diskUsr pattern, softkey 7-5, 8-9, 8-10, 8-15
- Display (HP 70004A) Line Voltage Selector 2-7
- Display Cleaning 1-13
- Display Fixed Label Keys 5-3
- Display Functions 5-4
- Display knob 5-3
- DISPLAY, hardkey 2-12, 2-17, 5-3, 5-4, 5-7, 13-8, 13-10
- Divided Clock Mode 4-10, 4-15
- Documentation Overview 3-3
  
- E**
- e, softkey 5-9, 7-31, 7-37, 10-5
- ED CLK FREQ, softkey 7-26
- ED ERR OUTPUT, softkey 7-24
- ED TRIG MODE, softkey 7-24
- ED TRIG PAT CLK, softkey 7-17, 11-26
- Edit Disk User Menu Map 6-7
- edit diskUsr, softkey 7-6, 8-6, 8-8, 8-13
- Edit Ram User Menu Map 6-7
- edit ram usr, softkey 5-11, 7-6, 8-5, 8-6, 8-8, 8-9, 8-11, 8-13, 8-16, 11-32
- Edit User Menu Map 6-8
- Edit User Pattern Menu 7-6
- Edit User Patterns 8-6
- edit-ramUsr, softkey 7-8
- ELAPSED GATING, softkey 7-26
- End of Measurement Period Logging 10-6
- ENTER CHAR, softkey 7-8
- ENTER, softkey 2-12, 5-9, 5-11, 7-31, 7-37, 8-7, 8-9, 8-10, 8-14, 10-5, 11-30, 11-32
- Entry Chart, Troubleshooting 13-2
- ERR CNT 0 to 1, softkey 7-27
- ERR CNT 1 to 0, softkey 7-27
- ERR FRE CENTI S, softkey 7-28

## Index - Operating Manual

- ERR FRE DECI S, softkey 7-28
  - ERR FRE MILL S, softkey 7-28
  - ERR FRE SECS, softkey 7-28
  - ERR O/P RZ200ns, softkey 7-17, 11-27
  - ERR RAT 0 to 1, softkey 7-27
  - ERR RAT 1 to 0, softkey 7-27
  - ERR-ADD EXTRNAL, softkey 7-14
  - ERR-ADD FIXED, softkey 5-10, 7-15, 11-24, 11-27, 11-28
  - ERR-ADD OFF, softkey 7-15
  - ERR-ADD SINGLE, softkey 7-14, 11-23, 11-28
  - Err-add Subrate USER'S PAGE menu 7-24
  - Error Add 4-8
  - Error Add Menu 7-14
  - Error Add Menu Map 6-9
  - error add, hardkey 4-8, 5-9, 7-14, 11-23, 11-27, 11-28
  - ERROR ADD, softkey 7-25
  - error add, softkey 7-14
  - Error Analysis 4-19, A-2
  - ERROR CENTI S, softkey 7-28
  - Error Count A-2
  - ERROR COUNT, softkey 7-27
  - ERROR DECI S, softkey 7-28
  - Error Detector 4-13
  - Error Detector Errors Output 7-17
  - Error Detector Performance Tests 11-25
  - Error Detector Trigger Output 7-17
  - Error Free Intervals A-2
  - Error Indicators 13-3, 13-4
  - Error Inject (internal and external) 11-23
  - Error Inject Input 4-12
  - error locat'n, hardkey 7-35
  - error locat'n, softkey 7-35
  - Error Location Analysis 4-20–4-21, 5-11, 7-35, A-3
  - Error location capture 4-20
  - Error Location Menu Map 6-15
  - error location, hardkey 4-21, 5-11, 11-32
  - Error Measurements A-2
  - Error Messages 12-1–12-9, 13-3, 13-8
  - ERROR MILLI S, softkey 7-28
  - Error Out 11-27
  - Error Performance Analyzer System Verification 2-17
  - Error Ratio A-2
  - ERROR RATIO, softkey 7-27
  - Error Reporting 13-8
  - ERROR SECS, softkey 7-28
  - Errored Intervals A-2
  - ERRORED SECS(%), softkey 7-29
  - Errors Output 4-15, 7-17
  - ERRORS, softkey 7-27
  - ESD Precautions 1-11
  - exit, softkey 7-5, 7-11, 7-27, 7-28, 7-29, 10-5, 10-6
  - Exiting the Editor By Mistake 8-5
  - EXT AC COUPLE, softkey 7-11, 7-13, 7-15
  - EXT CLK ATTEN, softkey 7-13
  - EXT DAT ATTEN, softkey 7-12
  - EXT DC TERM 0V, softkey 7-11, 7-13, 7-15
  - EXT DC TERM -2V, softkey 7-11, 7-13, 7-15
  - extrnl term, softkey 7-11
  - EYE EDG THRSHLD, softkey 4-17, 4-18, 5-9, 7-31, B-3
  - Eye Edge Threshold, softkey 11-30
  - EYE HEIGHT, softkey 7-29
  - Eye Results 4-17, 4-18, 7-22
  - Eye results USER'S PAGE menu 7-29
  - EYE RESULTS, softkey 4-17, 5-8, 7-31
  - EYE STATUS, softkey 7-29
  - EYE THRSHLD, softkey 7-25, 7-29
- F**
- F, softkey 7-8
  - FINISH ENTRY, softkey 7-8
  - First Measurement 5-7
  - Floppy Disk Read/Write 11-31
  - FORMAT DISK, softkey 11-31
  - format disk, softkey 7-9, 8-16
  - FORMAT YES, softkey 8-16
  - FREQ STEP, softkey 7-14

## Index - Operating Manual

Frequency Measurement 4-20  
Fuse Ratings 2-9

### G

G.821 Results 7-22  
G.821 results USER'S PAGE menu 7-29  
GATE BY BITS, softkey 7-34  
GATE BY ERRS, softkey 7-34  
GATE BY TIME, softkey 5-9, 7-34  
GATING DUR MOD, softkey 7-25  
Gating Err-loc USER'S PAGE menu 7-25  
Gating Indicator 13-3  
Gating Input 4-16  
Gating Input & Error Measurement 11-27  
Gating Menu 7-33  
Gating Menu Map 6-14  
Gating modes 4-22  
GATING OFF, softkey 10-7  
GATING ON, softkey 10-7  
Gating Period Definition 4-23  
GATING PERIOD, softkey 5-9, 7-25, 7-34  
GATING REPORT, softkey 7-25  
GATING RPT MOD, softkey 7-25  
gating, hardkey 4-22, 5-9, 7-33  
gating, softkey 7-33  
General 1-3  
Generate an Alternate Pattern 8-13  
goto bit, softkey 7-7, 8-7, 8-9, 8-11, 8-14, 8-15  
goto, softkey 5-11, 11-32  
green softkeys/window 5-3, 7-2  
green/yellow window 5-3, 7-2  
grey softkeys/window 5-3, 7-2

### H

Header String 8-19  
Header String Length 8-18  
hex entry, softkey 7-8  
HP 70843 Instrument Options 3-3  
HP 70843 Options 1-7  
HP 71612 Options 1-6

HP-IB (IEEE-488) to Centronics Printer  
Interface Converter 10-2  
HP-IB Address Switches 2-12  
HP-IB ADDRSET, softkey 2-12  
HP-IB Indicators 13-3  
HP-MSIB Address Switches 2-10–2-12  
HP-MSIB Troubleshooting 13-6

### I

Initial Inspection 2-3  
Initial Switch On 5-7  
Input & Eye Menu 7-30  
Input & Eye Menu Map 6-12  
input & eye, hardkey 2-17, 4-14, 4-17, 4-18, 5-8, 7-30, 7-31, 11-28, 11-29, 11-30  
input & eye, softkey 7-30  
Input & Sync USER'S PAGE menu 7-25  
INSERT REPLACE, softkey 5-11, 7-7, 11-32  
INSERT, softkey 7-7  
INSERT/REPLACE, softkey 8-7, 8-9  
INST PRESET, hardkey 2-17, 5-8, 9-2, 11-4, 11-10, 11-11, 11-17, 11-26, 11-28, 11-30, 11-31  
Installation procedure 2-15  
Installing an HP 70340A Clock Source Module into a Display 2-19  
Installing an HP 70341A Clock Source Module into a Mainframe 2-20  
Installing/Removing 2-19  
Installing/Removing Modules 2-2  
INSTR PRESETUP, softkey 11-27  
Instruction for cleaning 2-4  
Instrument (HP 70843) Line Voltage Selector 2-7  
Instrument Functions 5-5  
Instrument Hardkeys 5-3  
Instrument Softkeys 5-3  
Interface 4-10, 4-11, 4-12, 4-16  
Internal Disk Drive 4-5  
Internal Format of Pattern/Buffer file 8-18  
INTERNAL PATT, softkey 5-11

## Index - Operating Manual

- INTERNL PATT 1 to 4, softkey 8-8
- INTERNL PATT 4, softkey 8-9
- INTERNL PATT, softkey 7-6, 8-5, 8-6, 8-10, 8-11, 8-12, 8-13, 8-15, 11-32
- INTERNL PATT1, softkey 5-11, 8-6, 8-7, 11-32
- Interval results USER'S page menu 7-28
- Intervl Results 7-21
- Introducing Errors into the System 5-9
- Inverted Clock Falltime 11-9
- Inverted Clock Out Amplitude and Frequency 11-11
- Inverted Clock Risetime 11-9
- Inverted Data Falltime 11-6
- Inverted Data Jitter 11-7
- Inverted Data Out Amplitude 11-13
- Inverted Data Risetime 11-6
  
- K**
- Key Notation 5-2
- KEYBRD LOCK, softkey 7-18
  
- L**
- Lifting the HP 70843 1-12, 2-5
- Lifting/Carrying the HP 70843 1-12
- Line Final Test Data, HP 70843 11-37
- Line Final Test Data, HP 70843 option UHF 11-33
- Line Fuses 2-9
- Line Voltage Selection 2-7
- Load a Block of Data (PRBS) 8-9
- Load a Pattern Store Into the Editor 8-8
- Load a PRBS or User Pattern into the Editor 8-9
- Load a User Pattern Into the Editor 8-10
- load block, softkey 5-11, 7-7, 8-9, 8-10, 8-15, 11-32
- LOG ALARMS\*, softkey 7-36
- LOG ALARMS, softkey 7-26, 10-7
- LOG END ALWAYS, softkey 7-37
- LOG END ERRS>0\*, softkey 7-37
- LOG END ERRS>0, softkey 10-6
- LOG END RAT>THR\*, softkey 7-38
- Log On Demand 10-7
- LOG ON DEMAND, softkey 7-37, 10-7, 10-8
- LOG ON ERR SEC, softkey 7-37
- LOG ON RAT>THR\*, softkey 7-37
- LOG ON RAT>THR, softkey 10-5
- LOG PRD FULL, softkey 7-37
- LOG PRD FULLUSR\*, softkey 7-36
- LOG PRD FULLUSR, softkey 7-26, 7-37, 7-38, 10-6
- LOG PRD USR, softkey 7-37, 10-6
- Log Results at the End of the Measurement Period 10-6
- Log Results During Gating 10-5
- Log Results to an HP-IB External Printer 10-4
- LOG TO EXT CTL, softkey 7-36, 10-4
- LOG TO HPIB, softkey 7-36, 10-4, 10-5, 10-6
- Logging Alarms 10-7
- LOGGING DEVICE, softkey 7-25
- Logging During Gating 10-5
- Logging Functions, selecting 10-3
- Logging Menu 7-36
- Logging Menu Map 6-15
- LOGGING OFF ON, softkey 5-3, 7-36, 10-4, 10-5, 10-6
- LOGGING OFF, softkey 10-7
- LOGGING ON, softkey 10-7
- Logging Squelch 10-7
- LOGGING STATUS, softkey 7-25
- LOGGING THRSOLD, softkey 7-37
- Logging to External Printer 4-25
- Logging USER'S PAGE menu 7-25
- logging, hardkey 10-3, 10-4, 10-5, 10-6, 10-7
- logging, softkey 7-36, 10-3
- LONGEST RUNZERO, softkey 7-4, 7-5
  
- M**
- Main Results Display 7-20
- Main results USER'S PAGE menu 7-26

## Index - Operating Manual

MAIN RESULTS, softkey 5-10  
Mainframe Line Voltage Selector 2-8  
Making Your First Measurement 5-7  
MAN, softkey 7-30, 11-28  
MANUAL, softkey 7-33  
MARK DEN, softkey 11-17  
MARK DENSITY, softkey 8-9  
mark density, softkey 7-5, 8-9, 8-15  
Markdensity Menu Map 6-5  
Measurement Definitions A-2  
Measurement Period 4-22  
Measurement Period Features 4-22  
Measurements 4-18  
Menu Map when MENU Selected 6-2  
Menu Map when pattern Selected 6-3  
Menu Map when result pages Selected 6-3  
MENU, hardkey 2-17, 5-3, 5-5, 6-2, 7-2,  
7-3, 7-4, 7-9, 7-11, 7-13, 7-14, 7-15,  
7-16, 7-18, 7-20, 7-30, 7-32, 7-33, 7-35,  
7-36, 8-5  
MENU, softkey 10-3  
Misc Menu 7-18  
misc, softkey 1-13, 5-5, 7-2, 7-3, 7-18  
Miscellaneous Menu Map 6-12  
MMS Error Messages 13-8  
MORE ERRORS, softkey 13-8  
MSIB Address Switches 2-10–2-12  
MSIB Troubleshooting 13-6  
Multi-State Functions 5-3

### N

navigation key 7-2  
NEXT INSTR, softkey 5-7  
NEXT SCREEN, softkey 7-7, 8-7  
NO MODIFY, softkey 5-11, 8-9, 8-10,  
8-15, 11-32  
Noise Declaration 2-6  
Non-Permanent Errors 12-3  
Numeric Keypad 5-3

### O

OFF, hardkey 11-27

OFF, softkey 10-4, 10-5, 10-6, 10-7, 11-12  
OG PRD FULL, softkey 10-6  
ON, softkey 5-11, 8-13, 8-14, 10-4, 10-5,  
10-6, 11-28, 11-32  
ONCE, softkey 4-11, 7-10  
Operating and Storage Environment 2-4  
Operating Requirements 2-4  
Operating Temperature 4-2  
Options 1-2, 1-6  
Other Results Display 7-21  
Other results USER'S PAGE menu 7-27  
OTHER RESULTS, softkey 4-21  
Output Results via HP-IB to a Controller  
10-4

### P

Packaging Requirements 1-9  
Parallel Data/4 Outputs 11-20  
Parameter Control Keys 5-3  
Parametric Testing 11-3  
PAT, softkey 7-17, 11-17, 11-26  
Path Selection 7-3  
Pattern & Trigger USER'S PAGE menu  
7-24  
Pattern Contents 8-20  
Pattern Data Format 8-19  
Pattern Editor and Substrate Data B-4  
Pattern Generation B-3  
Pattern Generator 4-3  
Pattern Generator Tests 11-10  
Pattern Generator Trigger Output 7-16,  
11-17  
Pattern Index 8-20  
Pattern Label String Length 8-20  
Pattern Length 8-20  
Pattern Lengths Divisible By Four B-4  
Pattern Lengths Not Divisible By Four B-4  
Pattern Mode 4-10, 4-15  
Pattern Softkey Menus 7-4  
Pattern Stores 8-3  
Pattern Sync Output 11-26  
Pattern Synchronization 4-24  
Pattern Trigger Output (error detector) 4-14



## Index - Operating Manual

Pattern Verification 11-31  
pattern, hardkey 4-11, 5-11, 6-3, 7-3, 7-4,  
7-5, 7-6, 7-9, 8-5, 8-6, 8-8, 8-9, 8-11,  
8-13, 8-15, 8-16, 9-11, 11-31, 11-32  
Pattern, softkey 11-17, 11-26  
pattern, softkey 7-4, 7-9, 7-24  
Patterns 4-3  
Perform a data eye measurement 5-8  
Performance Test Record 11-33  
Performance Tests 11-1–11-37  
Permanent Errors 12-9  
PG CLK FREQ, softkey 7-26  
PG TRIG /8 /32, softkey 7-17  
PG TRIG A-B PAT, softkey 7-17  
PG TRIG BIT, softkey 7-16, 7-17  
PG TRIG MODE, softkey 7-24  
PG TRIG PAT CLK, softkey 7-16, 11-11,  
11-17  
PG TRIG PATTERN, softkey 7-17  
PG TRIGGER, softkey 7-24  
Physical Specifications 2-4  
Power Cables 2-6  
POWER LOSS s, softkey 7-28  
Power Loss Seconds A-3  
Power Requirements 2-5  
Power-loss Seconds 4-19  
PRBS Menu Map 6-4  
PRBS Test Patterns 4-3  
PRBS, softkey 11-26  
prbs, softkey 7-4  
Precautions 1-2, 1-11  
Preparation for Use 2-2, 2-3  
Preparing an Instrument for Shipping 1-10  
PRESET 0 Settings 9-3  
Preset 1 Configuration 9-8  
PRESET 1 Settings 9-8  
Preset 1, softkey 5-8, 9-2  
Preset 2 Configuration 9-10  
PRESET 2 Settings 9-10  
Preset 2, softkey 5-8, 9-2  
PRESET Instrument Configurations 9-2  
PREV SCREEN, softkey 7-7, 8-7, 8-15  
Primary Softkeys 7-3

Printer Address 10-3  
Printer Interface Cables 10-3  
Printers, recommended 10-2  
Procedure, First Measurement 5-7  
Procedure, installation 2-15

## R

Rack Mount Installation 2-13  
Ram User Menu Map 6-5  
ram Usr pattern, softkey 7-5, 8-9, 8-10,  
8-13, 9-11  
ram Usr, softkey 8-15  
ram, softkey 8-10  
RAM-Based File Catalog 8-4  
Rear Panel Switches 4-12  
recall setup, softkey 5-8, 7-18, 9-2  
Recommended Accessory List 1-8  
Recommended Printers 10-2  
REPEAT, softkey 7-33  
REPLACE, softkey 5-11, 7-7, 11-32  
REPORT ERRORS, softkey 13-8  
REPORT PREVCUR, softkey 7-34  
Residual Error Rate Test 11-31  
Result Logging 4-20  
Result Pages Menu 7-20  
result pages, hardkey 4-17, 4-21, 4-25,  
4-26, 5-8, 5-10, 6-3, 7-20, 7-23, 7-31  
result pages, softkey 7-20  
Results Storage 10-8  
Returning Instruments for Service 1-2, 1-9  
Revision Code 8-19  
RUN GATING, hardkey 2-17, 4-16, 4-22,  
5-9, 5-10  
RUN GATING, softkey 7-33  
Running out of Disk Space 8-16  
RZ, softkey 11-27

## S

S/R CLK AMPLTD, softkey 7-24  
S/R CLK HI-LEVL, softkey 7-25  
S/R CLK TERM, softkey 7-25  
S/R DAT AMPLTD, softkey 7-15, 7-24

## Index - Operating Manual

- S/R DAT ampltd, softkey 11-21
- S/R DAT ECL, softkey 7-15, 7-16
- S/R DAT Hi-level, softkey 11-21
- S/R DAT HI-LEVL, softkey 7-15, 7-16, 7-24
- S/R DAT TERM, softkey 7-24
- Safety Considerations 1-2
- Safety Information 1-2
- Safety Symbols 1-4
- Save a Block of Data 8-11
- Save a Pattern 8-8
- Save and Recall Instrument Setup 7-18
- save pattern, softkey 5-11, 7-7, 8-5, 8-8, 8-10, 8-15, 8-16, 11-32
- save setup, softkey 7-18
- save to ram, softkey 8-12
- save, softkey 7-8
- savedel block, softkey 7-8, 8-11
- savedel, softkey 7-8
- SCPI (Standard Commands for Programmable Instruments) 12-2
- SECONDS, softkey 5-9
- Select a Measurement Gating Period 5-9
- Select Alternate Pattern Control 8-13
- Selecting Logging Functions 10-3
- SELF TEST, softkey 7-20
- Selftest at Power-on 2-2, 2-18
- Serial Number Information 1-2, 1-9
- set clock, softkey 7-18
- SET PAT LABEL, softkey 7-8
- SET PAT LENGTH, softkey 7-8, 8-7, 8-14
- Set Up and Edit Your Own User Pattern 8-6-8-15
- Set Up the Display 5-4
- Set Up Your Own Display of Results or Status Information 4-25
- set zerosub, softkey 8-9, 8-15
- SETPAT LENGTH, softkey 5-11, 11-32
- Setting Error Detector Sync Thresholds B-2
- Setting Sync Thresholds B-2
- SEV ERR SECS(%), softkey 7-29
- SIG GEN AMPLTD, softkey 7-14
- SIG GEN FREQ, softkey 7-14
- SIG O/P ON OFF, softkey 7-14
- SINGLE, softkey 5-9, 7-33
- SMA connectors, torque setting 2-16
- Softkey Labelling 7-2
- Softkey Menus 7-2
- Softkeys and Windows Color Coding 5-3
- Softkeys Color Coding 7-2
- Softkeys requiring numeric entry 7-2
- SQUELCH OFF ON, softkey 7-36
- SQUELCH STATUS, softkey 7-26
- Standard Commands for Programmable Instruments (SCPI) 12-2
- Start a Measurement 5-9
- START SYNC, softkey 7-32
- Statement of Compliance 2-4
- Static-safe Accessories 1-12
- Static-safe Workstation 1-11
- Status Indicators 4-12
- STOP GATING, hardkey 4-16, 4-22
- STOP GATING, softkey 7-33
- Subrate Clock & Data Output Amplitude/Offset 11-21
- Subrate Clock Softkeys 7-15
- Subrate Data Softkeys 7-15
- Subrate Output Pattern Change with Trigger Bit Position B-4
- Subrate Outputs 4-9, 7-15
- Subrate Outputs Menu Map 6-10
- subrate outputs, hardkey 7-15, 11-18, 11-21
- subrate outputs, softkey 7-15
- Sync & Audio Menu 7-32
- Sync & Audio Menu Map 6-13
- sync & audio, hardkey 4-25, 7-32, 11-27, 11-28, B-2, B-3
- sync & audio, softkey 7-32
- SYNC AUTO/MAN, softkey 5-3
- SYNC AUTOMAN, softkey 7-32
- Sync Gain Loss Criteria 4-24
- Sync Loss and Errors Troubleshooting 13-10
- SYNC LOSS s, softkey 7-26
- SYNC MODE, softkey 7-25

Sync Threshold 4-24, 7-32, B-2  
SYNC THRSBLD, softkey 7-25  
Synchronization Modes 4-24  
Synchronization Times 4-24  
Sync-loss Seconds 4-20, A-3  
System Indicators 13-3  
System Installation 2-2, 2-14  
System Options 3-2  
System Turn-On 5-6  
System Verification 2-2, 2-17

## T

Test Equipment Required 11-2  
Testing 11-1–11-37, 13-1–13-10  
The Editor 8-3  
TIME CENTER, softkey 7-29  
To Fit an Instrument Hardkey Panel 2-3  
To Squelch or not to Squelch 10-7  
toggle disk usr, softkey 7-5  
toggle ram Usr, softkey 7-5  
toggle screen, softkey 5-11, 7-7, 8-6, 11-32  
toggle, softkey 7-6, 8-4, 8-8  
Torque setting, SMA connectors 2-16  
Trigger & Setup  
    Menu Map 6-11  
    Softkey Menu 7-16  
trigger & setup, hardkey 5-8, 7-16, 9-2,  
    11-4, 11-11, 11-26, 11-27  
trigger & setup, softkey 7-16  
trigger 1 sec\*, softkey 7-37  
TRIGGER 1 SEC, softkey 7-26  
trigger 1 sec, softkey 10-5  
Trigger Bit 8-20  
TRIGGER END PRD, softkey 7-26  
trigger end prd, softkey 7-37, 10-6  
Trigger Output 4-9, 7-16, 7-17  
TRIGGER THRSBLD\*, softkey 7-37  
TRIGGER THRSBLD, softkey 7-26, 10-5  
Troubleshooting 13-1–13-10  
Troubleshooting Entry Chart 13-2  
Type of Pattern 8-20

## U

Unable to write to disk 8-17  
UNAVAIL (%), softkey 7-29  
Update Control Processor Firmware 1-13  
update frmware, softkey 1-13, 7-19  
Update Measurement Processor Firmware  
    1-14  
Update the HP 70843 Firmware 1-13  
UPDATE YES, softkey 1-14  
UPDATE, softkey 1-13  
Updating Firmware 1-2  
UpdCntlAppl, softkey 1-13, 7-19  
UpdMeasAppl, softkey 1-14, 7-19  
Upgrade Options 1-8  
User Pattern Creation 8-6–8-15  
User Pattern Default Settings 9-11  
User Pattern Memory 4-4, 8-5  
User Patterns 8-1–8-20  
User's Page 7-22  
USER, hardkey 1-13, 7-2, 7-3  
USER'S PAGE, softkey 4-25, 4-26, 7-23  
User-programmable test patterns 4-4, 8-1–  
    8-20, B-3  
Using the HP 70004A Display 5-2  
USR, softkey 5-11, 7-10, 8-13, 10-6, 11-32

## V

Verify Capture Error 5-11  
Verify/Demonstrate the Capture Error  
    Feature 11-32  
Viewing Results 5-9  
Volt/Temp Troubleshooting 13-5  
VOLTAGE CENTER, softkey 7-29

## W

Warm-up 4-2  
When Measurement Results can be Logged  
    10-4

## Y

yellow softkeys 5-3, 7-2  
YES, softkey 5-11, 8-13, 11-32

## Index - Operating Manual

### Z

zero sub, softkey 7-4, 8-9

Zero Substitution/Variable Mark Density  
4-3

Zerosub Menu Map 6-4

**HP 71612 Series of Gb/s Testers**  
**Programming Manual**





## 1 Remote Operation

Introduction 1-2

**System Configuration 1-2**

**Interface Types 1-3**

**Hewlett-Packard Interface Bus (HP-IB) 1-3**

What is the HP-IB? 1-3

**Connecting the HP 71612 Series to the HP-IB 1-4**

Cabling Arrangements 1-4

**Using HP-IB 1-4**

Operating Distances 1-5

Instrument Mode at Power On 1-5

Address Configuration 1-5

Local and Remote Modes 1-6

Using Local and Remote Commands 1-6

HP-IB Required Commands 1-6

Device Clear (CLEAR) 1-7

Serial Poll (SPOLL) 1-7

Remote Enable (REMOTE) 1-7

Local Lockout (LOCAL LOCKOUT) 1-7

Local (LOCAL) 1-7

Sending Commands Over HP-IB 1-8

Using Non-HP Controllers 1-8

Invalid Commands 1-8

Reading Data 1-8

Message Format 1-9

String 1-9

Numeric 1-9

Integer 1-10

A Number with Embedded Decimal Point 1-10

A Number with Embedded Decimal Point and Exponent 1-10

Boolean Parameters 1-10

Block Data 1-10

## 2 Programming the HP 71612 Series

Introduction 2-2

**The HP 71612 Series Command Language 2-2**

SCPI IEEE 488.2 Common Commands 2-2

IEEE Mandatory Commands 2-3

IEEE Optional Commands 2-3

SCPI Instrument Control Commands 2-3

**Important Points about SCPI 2-4**

- Instrument Model 2-4
- Layered Command Structure 2-4
- Command Syntax 2-5
- Optional Commands 2-5
- Sending Commands 2-5
- Command Separators 2-5

**SCPI Command Structure 2-5**

- Command Structure Example 2-6

**Behavior at Power On 2-7**

**Device/Controller Synchronization Techniques 2-8**

- Overlapped Commands 2-8
- Sequential Commands 2-9
- Operation Complete Messages 2-9
- Overview of Control Sequence between Configuration Changes and the Commencement of Bit Error Measurements 2-9

**Handling Coupled Parameters 2-11**

**References 2-13**

**3 Interrogating the Instrument Status**

- Introduction 3-2

**HP 71612 Series Status Reporting 3-2**

- Internal Registers 3-2

**Generalized Status Register Group Model 3-3**

**HP 71612 Register Model 3-4**

**Status Byte Register Group 3-5**

- Serial Polling 3-6
- Status Byte Service Request Enable Register 3-6

**Standard Event Status Register Group 3-8**

- Standard Event Enable Register 3-9

**Clock Loss Register Group 3-10**

**Failure Status Register Group 3-11**

**Questionable Data Status Register Group 3-12**

- Interrogating Register Groups 3-13
- Interrogating the Condition and Event Registers 3-13
- Transition Filter 3-13
- Questionable Data Event Enable Register 3-14

**Operation Status Register Group 3-15**

- Interrogating the Condition and Event Registers 3-16
- Operation Status Transition Filter 3-16
- Operation Event Enable Register 3-16



**Interrupt Programming and Using the Service Request 3-17**

Generating a Service Request from the Operating Status Register 3-17

**4 Transferring USER Patterns over HP-IB**

Introduction 4-2

**Pattern Upload/Download Example 4-2**

Some General Hints 4-4

Visual Basic 4-5

Labview 4-5

**5 System Command Reference Section**

**Pattern Configuration 5-2**

[SOURCE[1]:]PATTERN[:SElect] <character data> 5-2

[SOURCE[1]:]PATTERN:ZSUBstitut[:ZRUN] <numeric value> 5-3

[SOURCE[1]:]PATTERN:MDENsity [:DENsity] <numeric value> 5-3

[SOURCE[1]:]PATTERN:UPATtern<n> [:LENGth] <numeric value> 5-3

[SOURCE[1]:]PATTERN:UPATtern<n>:LABel <string> 5-4

[SOURCE[1]:]PATTERN:UPATtern<n>:USE STRaight|APATtern 5-4

[SOURCE[1]:]PATTERN:UPATtern <n>:DATA [A|B,] <block\_data> 5-5

[SOURCE[1]:]PATTERN:UPATtern<n>:IDATa [A|B,] <start\_bit>,  
<length\_in\_bits>,<block\_data> 5-6

[SOURCE[1]:]PATTERN:UPATtern<n>:LMODified? <string> 5-6

Example 1 - Use of the :DATA command 5-7

Example 2: Use of the :IDATa command 5-9

[SOURCE[1]:]PATTERN:FORMat[:DATA] PACKed,<numeric value> 5-10

**Control of User Pattern A to B Changeover in the Generator 5-11**

[SOURCE[1]:]PATTERN:APCHange:SOURce EXTernal|INTernal 5-11

[SOURCE[1]:]PATTERN:APCHange:MODE ALTernate|ONEShot 5-11

[SOURCE[1]:]PATTERN:APCHange:SElect AHALf|BHALf 5-11

[SOURCE[1]:]PATTERN:APCHange:BHALf ONCE: 5-11

**Error Addition in the Pattern Generator 5-12**

[SOURCE[1]:]PATTERN:EADDITION ONCE|<boolean> 5-12

[SOURCE[1]:]PATTERN:EADDITION:SOURce EXTernal|FIXed 5-12

[SOURCE[1]:]PATTERN:EADDITION:RATE <numeric value>: 5-12

**User Pattern Disk Operations 5-13**

MMEMory:INITialize 5-13

MMEMory:DELeTe <file name> 5-13

MMEMory:CATalog? <NR3>,<NR3> { ,<file entry> } 5-13

MMEMory:MPResent? <boolean> 5-13

MMEMory:CPDisk <NR1> 5-14

## Contents - Programming Manual

MMEMory:ICPDisk <NR1>,AHALf BHALf,<NR1>,<NR1>	5-14
<b>Pattern Generator DATA OUT</b>	<b>5-15</b>
[SOURce[1]:]VOLTage[:LEVel][:IMMEDIATE][:AMPLitude] <numeric value>	5-15
[SOURce[1]:]VOLTage[:LEVel][:IMMEDIATE]:HIGH <numeric value>	5-15
[SOURce[1]:]VOLTage:ATTenuation <numeric value>	5-15
[SOURce[1]:]VOLTage:ECL	5-15
OUTPut1[:STATe] <boolean>	5-15
OUTPut1:COUPling AC DC	5-16
OUTPut1:POLarity NORMAl INVerted	5-16
OUTPut1:DELay <numeric value>	5-16
OUTPut1:TERMination <numeric value>	5-16
<b>Pattern Generator DATA OUT (inverted)</b>	<b>5-17</b>
SOURce10:VOLTage[:LEVel][:IMMEDIATE][AMPLitude] <numeric value>	5-17
SOURce10:VOLTage [:LEVel][:IMMEDIATE]:HIGH <numeric value>	5-17
SOURce10:VOLTage:TRACK <boolean>	5-17
OUTput10 [:STATE] <boolean>	5-17
<b>Pattern Generator CLOCK OUT</b>	<b>5-18</b>
SOURce2:FREQuency[:CWI:FIXed]? <numeric value>	5-18
SOURce2:VOLTage [:LEVel][:IMMEDIATE][:AMPLitude] <numeric value>	5-18
SOURce2:VOLTage[LEVel][:IMMEDIATE]:HIGH <numeric value>	5-18
SOURce2:VOLTage:ATTenuation <numeric value>	5-18
SOURce2VOLTage:ECL	5-18
OUTPut2:TERMination <numeric value>	5-19
OUTPut2:COUPling AC DC	5-19
<b>Pattern Generator CLOCK OUT (inverted)</b>	<b>5-19</b>
SOURce11:VOLTage[:LEVel][:IMMEDIATE][:AMPLitude] <numeric value>	5-19
SOURce11:VOLTage[:LEVel][:IMMEDIATE]:HIGH <numeric value>	5-19
SOURce11:VOLTage:TRACK <boolean>	5-19
<b>Pattern Generator PARALLEL DATA OUTPUTS</b>	<b>5-20</b>
SOURce4:VOLTage[:LEVel][:IMMEDIATE][:AMPLitude] <numeric value>	5-20
SOURce4:VOLTage[:LEVel] [:IMMEDIATE]:HIGH <numeric value>	5-20
SOURce4:VOLTage:ECL	5-20
OUTPut4:TERMination <numeric value>	5-20
OUTPut4:COUPling AC DC	5-20
<b>Pattern Generator SUBRATE CLOCK OUT</b>	<b>5-21</b>
SOURce5:VOLTage[:LEVel][:IMMEDIATE][:AMPLitude] <numeric value>	5-21
SOURce5:VOLTage[:LEVel][:IMMEDIATE]:HIGH <numeric value>	5-21
SOURce5:VOLTage:ECL	5-21
OUTPut5:TERMination <numeric value>	5-21

OUTPut5:COUPling AC DC	5-21
<b>Pattern Generator TRIGGER OUTPUT</b>	<b>5-22</b>
SOURCE3:TRIGger[:MODE] PATTern DCLock	5-22
SOURCE3:TRIGger:DCDRatio <NR1>	5-22
SOURCE3:TRIGger:CTDRatio? <NR3>	5-22
SOURCE3:TRIGger:PRBS<n> <NRf>{,<NRf>}	5-22
SOURCE3:TRIGger:ZSUB<n> <numeric value>	5-23
SOURCE3:TRIGger:MDEN<n> <numeric value>	5-23
SOURCE3:TRIGger:UPAT<n> <numeric value>	5-23
SOURCE3:TRIGger:APATtern<n> ABCHange SOPattern	5-23
<b>Pattern Generator CLOCK IN</b>	<b>5-24</b>
SENSe6:FREQuency [:CW]:FIXed]?	5-24
SENSe6:BANDswitch?	5-24
<b>Slaved MMS Clock Source</b>	<b>5-25</b>
SOURCE9:IDN? <string>	5-25
SOURCE9:FREQuency	5-25
SOURCE9:FREQuency:STEP <numeric value>	5-25
SOURCE9:POWer [:LEVel][:IMMediate][:AMPLitude] <numeric value>	5-25
SOURCE9:OUTPut <boolean>	5-25
<b>Error Detector DATA IN</b>	<b>5-26</b>
SENSe[1]:VOLTage:ZOTHreshold <numeric value>	5-26
SENSe[1]:VOLTage:ZOTHreshold:AUTO <boolean>	5-26
SENSe[1]:EYE:TCENter ONCE <boolean>	5-26
SENSe[1]:EYE:ACENter ONCE <boolean>	5-27
SENSe[1]:EYE:WIDTh? <NR3>	5-27
SENSe[1]:EYE:HEIGHt? <NR3>	5-28
SENSe[1]:EYE:THReshold <numeric value>	5-28
INPut1:POLarity NORMAl INVerted	5-28
INPut1:DELay <numeric value>	5-28
INPut1:TERMination <numeric value>	5-28
<b>Error Detector CLOCK IN</b>	<b>5-29</b>
SENSe2:FREQuency?	5-29
SENSe2:BANDswitch?	5-29
INPut2:TERMination <numeric value>	5-29
<b>Error Detector TRIGGER OUTPUT</b>	<b>5-30</b>
SOURCE7:TRIGger[:MODE] PATTern DCLock	5-30
<b>Error Detector ERRORS OUTPUT</b>	<b>5-30</b>
OUTPut8:PLENgtH RZ STRetched	5-30
<b>Error Detector Pattern Synchronization</b>	<b>5-31</b>
SENSe[1]:SYNchronisat ONCE <boolean>	5-31
SENSe[1]:SYNChronisat:THReshold <numeric value>	5-31
<b>Error Detector Measurement Gating</b>	<b>5-32</b>
SENSe[1]:GATE ON	5-32

## Contents - Programming Manual

SENSe[1]:GATE:BURSt <boolean>	5-32
SENSe[1]:GATE:MODE MANual SINGle REPetitive	5-32
SENSe[1]:GATE:MANNer TIME ERRors BITS	5-33
SENSe[1]:GATE:PERiod	5-33
SENSe[1]:GATE:PERiod[:TIME] <numeric value>	5-33
SENSe[1]:GATE:PERiod:ERRors <numeric value>	5-33
SENSe[1]:GATE:PERiod:BITS <numeric value>	5-33
<b>Error Detector Error Location</b>	<b>5-34</b>
SENSe[1]:ELOCation ONCE	5-34
SENSe[1]:ELOCation?	5-34
SENSe[1]:ELOCation:BEAdress <numeric value>	5-34
SENSe[1]:BLOCK <boolean>	5-35
SENSe[1]:BLOCK:BSTart <numeric value>	5-35
SENSe[1]:BLOCK:BLENght <numeric value>	5-35
<b>Error Detector Measurement Functions</b>	<b>5-36</b>
FETCH[:SENSe[1]]:ECOut	5-36
FETCH[:SENSe[1]]:ERATio	5-37
FETCH[:SENSe[1]]:EINTerval	5-37
FETCH[:SENSe[1]]:EFINTerval	5-38
FETCH[:SENSe[1]]:LOSS:POWer? <NR3>	5-38
FETCH[:SENSe[1]]:LOSS:SYNChronisat? <NR3>	5-38
FETCH[:SENSe[1]]:G821	5-38
FETCH[:SENSe[1]]:GATE	5-38
FETCH[:SENSe[1]]:GATE:ELAPsed? <NR3>	5-39
FETCH[:SENSe[1]]:LTEXT?	5-39
FETCH:SENSe2:FREQuency? <NR3>	5-39
FETCH:SENSe2:BCOut?	5-39
<b>Result and Configuration Window Selection and Composition</b>	<b>5-40</b>
DISPlay: WINDOW	5-40
DISPlay:WINDow[:RESults] <parameter>	5-40
DISPlay:WINDow:CONFig <parameter>	5-40
DISPlay:REPort PREVious CURRent	5-41
DISPlay:UPAGe[:DEFine] <parameter>	5-41
DISPlay:UPAGe:CLEar	5-44
<b>Error Detector Result and Configuration Logging</b>	<b>5-45</b>
SENSe[1]:LOGGing ONCE <boolean>	5-45
SENSe[1]:LOGGing:SQUelch <boolean>	5-45
SENSe[1]:LOGGing:ALARms <boolean>	5-45
SENSe[1]:LOGGing:THReshold <numeric parm>	5-46
SENSe[1]:LOGGing:DURing[:EVENT] NEVer ESECond ERGThrshld	5-46
SENSe[1]:LOGGing:END[EVENT]NEVer ALWays NZECount  TERGthrshld	5-46
SENSe[1]:LOGGing:END:REPort FULL UREP	5-46

## Contents - Programming Manual

### System Level Status and Control 5-47

- Audio Output on Bit Errors 5-47
- SYSTem:BEEPer[:IMMediate] [<freq> [,<time> [,<vol>]]] 5-47
- SYSTem:BEEPer:STATe <boolean> 5-47
- SYSTem:BEEPer:VOLume <numeric value> 5-47
- SYSTem:ERRor? 5-47
- SYSTem:KLOCK <boolean> 5-48
- SYSTem:PRESet|:PRESet<n> 5-48
- SYSTem:VERSion? 5-48
- SYSTem:DATE <year>,<month>,<day> 5-48
- SYSTem:TIME <hour>,<minute>,<second> 5-48
- SYSTem:FREVision[:CPRocessor][:APPLication]? 5-49
- SYSTem:FREVision[:CPRocessor]BOOT? 5-49
- SYSTem:FREVision[:MPRocessor][:APPLication]? 5-49
- SYSTem:FREVision[:MPRocessor]BOOT? 5-49
- SYSTem:FUPDate CAPPLication|MAPPLication 5-49

### Instrument Status 5-50

- STATus:OPERation:[EVENT|CONDition|ENABLE|PTRansition|NTRansition] 5-50
- STATus:QUEStionable:[EVENT|CONDition|ENABLE|PTRansition|NTRansition] 5-50
- STATus:CLOSs Register:[EVENT|CONDition|ENABLE|PTRansition|NTRansition] 5-51
- STATus:FAILure:EVENT 5-51
- STATus:PRESet 5-51

### IEEE Common Commands and Queries 5-52

- IEEE Mandatory Commands 5-52
- IEEE Optional Commands 5-52
  - Response to Identification Common Query \*IDN? 5-52
  - Effect of Common Command \*RST 5-53
  - Scope of the Common Command \*TST? 5-53
  - Response to Identification Common Query \*OPT? 5-53
  - Effect of the Common Command \*RCL 5-53

## 6 TMSL Command Definition Quick Reference Guide

Introduction 6-2

### The Pattern Generator 6-3

#### Port 1: the pattern generator data output port 6-3

- SOURce1: The Data Source 6-3
- OUTPut1: The Data Output 6-4

## Contents - Programming Manual

<b>Port 2: the pattern generator clock output port</b>	<b>6-5</b>
SOURce2: The Clock Source	6-5
OUTPut2: The Clock Output	6-5
<b>Port 3: the pattern generator trigger output port</b>	<b>6-6</b>
SOURce3: The Trigger Source	6-6
<b>Port 4: the pattern generator subrate data output port</b>	<b>6-7</b>
SOURce4: The Subrate Data Source	6-7
OUTPut4: The Subrate Data Output	6-7
<b>Port 5: the pattern generator subrate clock output port</b>	<b>6-8</b>
SOURce5: The Subrate Clock Source	6-8
OUTPut5: The Subrate Clock Output	6-8
<b>Port 6: the pattern generator clock input port</b>	<b>6-8</b>
SENSe6: The Clock Sense	6-8
<b>Port 10: the pattern generator data (inverted) output port</b>	<b>6-9</b>
SOURce10: The Data (inverted) Source	6-9
OUTPut10: The Data (inverted) Output	6-9
<b>Port 11: the pattern generator clock (inverted) output port</b>	<b>6-9</b>
SOURce11: The Clock Source	6-9
<b>The Error Detector</b>	<b>6-10</b>
<b>Port 1: the error detector data input port</b>	<b>6-10</b>
SENSe1: The Data Sense	6-10
INPut1: The Data Input	6-12
<b>Port 2: the error detector clock input port</b>	<b>6-13</b>
SENSe2: The Clock Sense	6-13
INPut2: The Clock Input	6-13
<b>Port 7: the error detector trigger output port</b>	<b>6-13</b>
SOURce7: The Trigger Source	6-13
<b>Port 8: the error detector error output port</b>	<b>6-13</b>
OUTPut8: The Errors Output	6-13
<b>The error detector measurement subsystem</b>	<b>6-14</b>
<b>Common Commands</b>	<b>6-16</b>
The DISPlay subsystem	6-16
The MMEMory subsystem	6-19
The SYSTem subsystem	6-19
The STATus subsystem	6-20
<b>Port 9: the slaved MMS signal generator clock output port</b>	<b>6-22</b>
SOURce9: The Clock Source	6-22
<b>IEEE Common Commands</b>	<b>6-23</b>
Mandatory Commands	6-23
Optional Commands	6-23

## **7 SCPI Conformance Information**

- Introduction 7-2
- SCPI Version 7-2**
- SCPI Confirmed Commands 7-2**
- SCPI Approved Commands 7-7**
- Non-SCPI Commands 7-7**

## **8 SCPI Messages**

- Introduction 8-2
- No Error 8-2**
- Command Errors [-199, -100] 8-3**
- Execution Errors [-299, -200] 8-8**
- Query Errors [-499, -400] 8-14**

## **9 Program Examples**

- Introduction 9-2
- Clock Stabilization 9-2
- RMB-UX Basic Language Example of the Use of BANDswitch? 9-3
- Testing and Gaining Pattern Synchronization 9-7**
- Performing Clock To Data Delay Alignment 9-8**

## **10 Sales and Service Offices**





---

## Remote Operation

## Remote Operation System Configuration

### Introduction

This section contains the information required to operate the instrument remotely using a suitable Controller. The aspects of remote operation covered are as follows:

- System Configuration.
- Interface Types.
- Hewlett-Packard Interface Bus.
- Connecting the HP 71612 Series to the HP-IB.
- Using HP-IB.

---

### System Configuration

The HP 71612 Option UHF error performance analyzer system is factory preset to the following configuration:

Model No.	Description	MS-IB Address
HP 70843 UHF	12 GHz Error Performance Analyzer	0,18

Changing the address is simply a matter of changing the setting of a small DIP switch inside the module. Full details of this operation are in Chapter 2 *Installation* of the Operating Manual.

For more information about master operation, slave operation and MS-IB addressing refer to Chapter 2 *Programming the HP 71612 Series* of this manual.

---

**NOTE** The examples given in the following text assume that the instrument is controlled by an interface with select code 7 and an HP-IB address of 18.

---

## Interface Types

There are two communications interfaces used in the HP 71612 Series. The MS-IB (Measurement System Interface Bus) and the HP-IB (Hewlett-Packard Interface Bus).

**MS-IB** The Measurement System Interface Bus is the interface used for internal communication between system modules on the Modular Measurement System (MMS).

**HP-IB** The Hewlett-Packard Interface Bus is the interface used for communication between a controller and external devices such as the HP 71612 Series. The HP-IB conforms to IEEE standard 488-1978, ANSII standard MC 1.1 and IEC Recommendation 625-1.

---

**NOTE** If you are using the HP-IB or MS-IB interfaces for the first time read this section first. More information about configuring the HP 71612 Series is contained in the Installation chapter

---

---

## Hewlett-Packard Interface Bus (HP-IB)

### What is the HP-IB?

The Hewlett-Packard Interface Bus (HP-IB) is Hewlett-Packard's implementation of IEEE standard 488-1978, ANSII standard MC 1.1 and IEC Recommendation 625-1.

The HP-IB Interface is easy to use. It allows flexibility in both communicating and controlling data between a controller and the HP 71612. It is also one of the easiest methods of constructing automatic test systems.

Devices on the bus fall into one of two categories, controller or non-controller. For example, the simplest system (two non-controllers) where one instrument is configured to send data continuously - known as TALKING and the other instrument (such as a printer) is configured to receive data continuously - known as LISTENING. Most devices can perform both roles, TALK or LISTEN, but not simultaneously. Usually a controller controls which instrument TALKS and which instrument LISTENS. The HP 71612 Series can TALK and LISTEN when instructed to do so by a suitable controller. In addition it can operate without a controller when logging results or screen dumping to an external printer.

## **Remote Operation**

### **Connecting the HP 71612 Series to the HP-IB**

The controller may also manage other instruments connected in the same bus configuration, addressing only one instrument, to carry out the data transfer or TALK function.

Further information on HP-IB standards and concepts is available in the following publications:

- IEEE Interface Standard 488-1978.
- ANSIL Interface Standard MC 1.1.
- Improving Measurements in Engineering and Manufacturing (HP P/N 5952-0078).
- Condensed Description of the Hewlett-Packard Interface Bus (HP P/N 59401-90030).

---

## **Connecting the HP 71612 Series to the HP-IB**

### **Cabling Arrangements**

Connect an HP-IB cable from the Controller to the HP 70843 error performance analyzer.

---

## **Using HP-IB**

You should consider the following when connecting the instrument for operation over the HP-IB.

- Operating Distances.
- Instrument Mode at Power On.
- Address Configuration.
- Local and Remote Modes.
- Using Local and Remote Commands.
- HP-IB Required Commands.
- Sending Commands Over the HP-IB.
- Using Non-HP Controllers.
- Invalid Commands.
- Reading Data.
- Message Format.

## Remote Operation Using HP-IB

### Operating Distances

Up to 15 instruments can be connected on a local bus system, but it is important to ensure that the maximum HP-IB cable length between instruments is less than 2 meters. In addition the total cabling should not exceed 20 meters.

Some useful cable part numbers are listed in Table 1-1.

**Table 1-1**

**Part Numbers of HP-IB Cables**

Description	HP Part Number
1 m	HP 10833A
2 m	HP 10833B
4 m	HP 10833C
0.5 m	HP 10833D

For distances up to 1250 m a suitable bus extender such as an HP 37204A can be used. Two bus extenders are required, one at the local bus and one at the remote bus. For distances beyond 1250 m, two HP 37204A bus extenders with suitable modems must be employed.

### Instrument Mode at Power On

At power on the HP 71612 Series will wake up in the same mode as it was powered down in. Normally, at power on, the HP 71612 Series is ready for either front panel operation or remote operation.

---

**CAUTION**

No HP-IB activity should take place within 20 seconds of system power up, as this will effect the system power up routine and may result in system hang up.

---

### Address Configuration

When configuring a HP-IB based system it is essential that each device on the HP-IB has a unique address. The device address can be in the range of 1 to 30. For a controller to communicate with a device over the HP-IB it must send the commands to the appropriate HP-IB device address.

## Remote Operation Using HP-IB

### Local and Remote Modes

The HP 71612 Series can be operated in one of two modes: local or remote.

In local operation, all the front controls are responsive and control the instrument.

In remote operation the softkeys which configure the system are inoperative, with exception of the display softkeys, and the instrument is controlled by the HP-IB controller. The front panel display reflects the remote programming commands received.

### Using Local and Remote Commands

At power on the instrument is in local mode and is sent into remote mode by one of two methods.

The first method uses a dedicated command and with HP Basic this is the REMOTE command followed by the instrument address, that is REMOTE 718.

The second method is by sending any command string to the instrument. The instrument will recognize the command string, set itself to the remote mode and then act on that command.

There are three ways to return the instrument back to local mode. The first method is to use the HP Basic command LOCAL plus the instrument address, that is LOCAL 718. The second method is to press the front panel LCL key. The third method is to cycle power to the instrument.

---

**NOTE**

The instrument behaves differently in LOCAL mode if a LOCAL command is asserted on the interface bus by the controller. For example, to assert a local condition at interface 7, the command is simply LOCAL 7. When this condition is present sending a command string to the instrument will not cause it to enter the remote state. It will however act on the command string but remain in the local state.

To cancel the LOCAL 7 state you must use the REMOTE 7 command.

---

### HP-IB Required Commands

The Required Commands perform the most basic remote functions over HP-IB and are common to all HP-IB controllable instruments. The commands are as follows:

- DEVICE CLEAR
- SERIAL POLL
- REMOTE ENABLE
- LOCAL LOCKOUT
- GO TO LOCAL

## Remote Operation Using HP-IB

### Device Clear (CLEAR)

This command initializes the instrument HP-IB hardware.

The command format using HP 200/300 Series Basic is, for example:

```
CLEAR 718
```

### Serial Poll (SPOLL)

A serial poll will retrieve the value of the primary status byte. This byte contains useful information about the current state of the instrument. For example:

```
SPOLL(718)
```

### Remote Enable (REMOTE)

The Remote command instructs the instrument to enter the REMOTE state and be ready to accept instructions via HP-IB.

When the HP 71612 receives this command it illuminates the front panel REMOTE LED, for example:

```
REMOTE 718
```

### Local Lockout (LOCAL LOCKOUT)

It is recommended that the Local Lockout command is sent after the Remote. This disables the front panel local key preventing the return to local mode and thus any interference to the instrument settings.

It should always be preceded by the REMOTE command, for example:

```
LOCAL LOCKOUT 7 (configures all the instruments on the bus to the Local Lockout condition.)
```

---

**NOTE**

If the instrument has been set to the LOCAL LOCKOUT condition, then the front panel LOCAL key is disabled. The instrument can only be returned to LOCAL operation by the controller sending the LOCAL command or by cycling power to the instrument.

---

### Local (LOCAL)

The Local command returns the instrument from Remote operation to local front panel control, for example:

```
LOCAL 7 or LOCAL 718
```

## Remote Operation Using HP-IB

### Sending Commands Over HP-IB

To send commands over the HP-IB involves sending the command string via the interface select code to the device address. HP Computers use the Basic instruction OUTPUT to send command strings. The structure of a command line is as follows:

OUTPUT interface select code + device address; “command string”

---

**NOTE** The semi-colon symbol is the command separator and must be included. The command string must be enclosed in inverted commas

---

Using an HP 300 Series Controller with its HP-IB interface set at select code 7 and a device at address 18, a typical command line to reset the instrument would appear as follows:

OUTPUT 718;“\*RST”

### Using Non-HP Controllers

With non-HP controllers it may be necessary to send a suitable command terminator after the data message, the terminator can be:

- ASCII newline (identical to the line feed character, LF).
- ASCII carriage return + 1 line feed, i.e. CR/LF.

In most HP controllers the CR/LF is sent automatically when HP Basic OUTPUT statements are used.

### Invalid Commands

A command will be rejected if:

- It contains a syntax error.
- It cannot be identified.
- It has too few or too many parameters.
- A parameter is out of range.
- It is out of context.

### Reading Data

It is possible to interrogate the individual settings and status of a device using query commands. Retrieving data is a two stage operation.

The query command is sent from the controller using the OUTPUT statement and the data is read from the device using the ENTER statement. A typical example, using the SCPI



## Remote Operation Using HP-IB

IEEE 488.2 Common Command “\*IDN?” querying the identity of a device, is given as follows:

```
OUTPUT 718;“*IDN?”  
ENTER 718;Identity$  
PRINT Identity $
```

Typically this would display the identity string:

```
“HEWLETT-PACKARD,70843A,3331U00101,A.01.01”.
```

---

### NOTE

When sending strings to the instrument either the double quote (“) or the single quote may be used (‘), the former being more suited to PASCAL programs which make use of single quote, the latter being more suited to use in BASIC programs, which uses double quote as a delimiter. In this manual the double quote has been used throughout.

---

## Message Format

The HP 71612 Series has the capability of returning data in the following formats:

- STRING
- NUMERIC
- BOOLEAN
- BLOCK DATA

### String

The following example returns an ASCII string representing the instrument serial number, enclosed in quotes. This should be entered into a string variable.

Example:

```
10 OUTPUT 718;“*IDN?”  
20 ENTER 718;Serial$  
30 PRINT Serial$  
40 END
```

Possible Result = “HEWLETT-PACKARD,70843A,3331U00101,A.01.01”

### Numeric

Returns one of three numeric formats and can be entered into a string or numeric variable. The three formats are:

- An integer.
- A number with embedded decimal point.
- A number with embedded decimal point and exponent.

## Remote Operation Using HP-IB

### Integer

Example:

```
10 OUTPUT 718;“*STB?”  
20 ENTER 718;Status_byte$  
30 PRINT Status_byte$  
40 END
```

Requests the contents of the status byte. Possible Result = +64

### A Number with Embedded Decimal Point

Example:

```
10 OUTPUT 718;“:SENSe1:VOLTAGE:ZOTHRESHOLD?”  
20 ENTER 718;Level$  
30 PRINT Level$  
40 END
```

Requests the current voltage threshold that the system is operating at.

### A Number with Embedded Decimal Point and Exponent

Example:

```
10 OUTPUT 718;“FETCH:ECOUNT?”  
20 ENTER 718;Error_count  
30 PRINT Error_count  
40 END
```

Requests the frequency at which the system is operating.

Possible Result = +9.91000000E+012

### Boolean Parameters

Boolean parameters are used to indicate whether a condition is true or false. A numeric value is returned where 1 = true and 0 = false.

### Block Data

Block data is used when large quantities of related data is being returned. Blocks are returned as definite length blocks.

---

**Programming the HP 71612  
Series**

## **Introduction**

This section gives information on how to begin programming the HP 71612 Series.

The section covers the following topics:

- The HP 71612 Series Command Language.
- Command Types.
- Important Points about SCPI.
- SCPI Command Structure.
- Master and Slave Operation.
- Configuration Required for Remote Operation.

---

## **The HP 71612 Series Command Language**

The HP 71612 Series conforms to the standard language for remote control of instruments. Standard Commands for Programmable Instruments (SCPI) is the universal programming language for instrument control.

SCPI can be subdivided into two distinct command sets.

- Common Commands
- Instrument Control Commands

### **SCPI IEEE 488.2 Common Commands**

This is a common command set which conforms to IEEE 488.2 and which contains general housekeeping commands.

The common commands are always headed by an asterisk. A typical example is the reset command:

```
OUTPUT 718;“*RST”
```

The IEEE 488.2 command set also contains query commands. Query commands always end with a question mark. A typical example is the command querying the identity of a device at address 718.

```
OUTPUT 718;“*IDN?”  
ENTER 718;Identity$
```

A full list of commands can be found in chapter 5, *System Command Reference Section*.

**Programming the HP 71612 Series**  
**The HP 71612 Series Command Language**

## **IEEE Mandatory Commands**

The following IEEE 488.2 mandatory commands are implemented:

*CLS	Clear Status Command.
*ESE	Standard Event Status Enable Command.
*ESE?	Standard Event Status Enable Query.
*ESR?	Standard Event Status Register Query.
*IDN?	Identification Query.
*OPC	Operation Complete Command.
*OPC?	Operation Complete Query.
*RST	Reset Command.
*SRE	Service Request Enable Command.
*SRE?	Service Request Enable Query.
*STB?	Read Status Byte Query.
*TST?	Self-Test Query.
*WAI	Wait-to-Continue Command.

## **IEEE Optional Commands**

The following optional commands are implemented:

*OPT?	Option Identification Query.
*PSC	Power On Status Clear Command.
*PSC?	Power On Status Clear Query.
*RCL	Recall device setup.
*SAV	Save device setup.

## **SCPI Instrument Control Commands**

SCPI is the command language used to setup and control the HP 71612 Series hardware. It is a powerful command set designed for electronic test and measurement hardware.

SCPI is an extension of IEEE 488.2 and is a standard set of programming commands for all Hewlett-Packard test and measurement instrumentation. This section will explain the implementation of SCPI in the HP 71612 Series. For further information on SCPI refer to the Beginner's Guide to †TMSL, part number H2325-90001.

† TMSL (Test and Measurement System Language) is Hewlett-Packard's original implementation of SCPI.

## Programming the HP 71612 Series

### Important Points about SCPI

---

**NOTE**

The response of the instrument to the \*RST, \*RCL or SYSTEM:PRESET commands may be up to 3 seconds. Any HP-IB program using these commands should have a time-out of greater than 3 seconds.

---

---

## Important Points about SCPI

There are a number of key areas to consider when using SCPI for the first time.

These are as follows:

- Instrument Model.
- Layered Command Structure.
- Command Syntax.
- Optional Commands.
- Sending Commands.
- Command Separators.

### Instrument Model

SCPI guidelines require that the HP 71612 Series conforms to an instrument model. This ensures that when using SCPI, functional compatibility is achieved between instruments which perform the same tasks. For example, if two different instruments have a programmable clock frequency setting then both instruments would use the same SCPI commands to set their frequency. The instrument model is made up of a number of subsystems. Each subsystem is associated with a particular module in the modular measurement system (MMS).

The sub-system defines a group of functions within a module and has a unique identifier under SCPI which is called the Root Keyword.

For more detail on the instrument model refer to chapter 5, *System Command Reference Section*.

### Layered Command Structure

The SCPI command structure is best explained by equating it with the HP 71612 Series instrument model. The top layer in SCPI identifies a sub-system within the modular measurement system (MMS). The next layer down is a command relating to that module or instrument within the MMS. The bottom layer is any parameter that is associated with that given command.

---

## Command Syntax

Commands may be up to twelve characters long but a shortform version is also available which has a preferred length of four characters. In this document the longform and shortform versions are shown as a single word with the shortform being shown in upper-case letters. For example, the longform node command **SOURCE** has the shortform **SOUR**. Using the shortform saves time when entering a program, however using the longform makes a program more descriptive and easy to understand.

In the Command Reference chapter any command used to set the value of any configurable parameter also has a query form. For brevity, the query form of each command is not shown in the text. Where a command ending in a question mark does appear, it is a query only command.

## Optional Commands

Some layers in the SCPI command structure are optional. A typical example is where a command is unique to one module. In this case the top layer (that is, the Root Keyword) of the command structure may be omitted.

## Sending Commands

Commands are sent over the HP-IB in the same way that HP-IB and IEEE 488.2 common commands are sent. HP controllers use the HP BASIC instruction OUTPUT to send commands strings. The only difference with SCPI is the structure of the command string.

## Command Separators

The SCPI command structure is hierarchical and is governed by a number of symbols. For example, a change in the command hierarchy is indicated by a colon, similar level commands are separated by a semi-colon and parameters are separated by a comma. This is explained in more detail in the following section, SCPI Command Structure.

---

## SCPI Command Structure

As previously stated the SCPI command set has a hierarchical layered structure.

The structure is as follows:

Root Keyword + Command Keyword + Parameter(s)

**Programming the HP 71612 Series  
SCPI Command Structure**

Root Keyword	<p>The Root Keyword is the top layer in the command structure. It identifies a subsystem within a module, which is contained in the modular measurement system.</p> <p>Refer to the table Definition of Input/Output Ports on page 5-1 in the Quick Reference Guide chapter. Each of the pattern generator and error detector port names identifies a SCPI subsystem in the HP 71612 Series where the port name is used as the Root Keyword for all commands effecting that subsystem.</p> <p>There are 4 SCPI subsystems not associated with input/output ports;</p> <table> <tr> <td>FETCh/PFETCh</td> <td>the Measurement Subsystem</td> </tr> <tr> <td>DISPlay</td> <td>the Display Subsystem</td> </tr> <tr> <td>SYSTem</td> <td>the System Subsystem</td> </tr> <tr> <td>STATus</td> <td>the Status Subsystem</td> </tr> </table> <p>Some root keywords may be optional if the destination of the command is implicit in the Command Keyword.</p>	FETCh/PFETCh	the Measurement Subsystem	DISPlay	the Display Subsystem	SYSTem	the System Subsystem	STATus	the Status Subsystem
FETCh/PFETCh	the Measurement Subsystem								
DISPlay	the Display Subsystem								
SYSTem	the System Subsystem								
STATus	the Status Subsystem								
Command Keyword	<p>The layer below the Root Keyword is the Command Keyword. It describes the feature on the system which is to be changed. It will always be present in any command string and may have additional associated commands.</p>								
Parameter	<p>The command parameters are the lowest layer in the SCPI command structure. They may be required by the Command Keyword and are numeric, string, boolean or block data.</p>								

Taking one command as an example we can examine this structure further.

**Command Structure Example**

In the following example we will examine a section of the pattern generator pattern selection command for the HP 70843 Option UHG pattern generator and HP 70843 Option UHF error performance analyzer systems.

The pattern command can be illustrated as follows:

<b>Root Keyword</b>	<b>Command Keyword</b>	<b>Parameter(s)</b>
[SOURce[1]:]	PATtern	
	[:SElect]	PRBS(n) ZSUBstitut(n) MDENsity(n) UPATtern(n)
	[:SElect]?	PRBS(n) ZSUB(n) MDEN(n) UPAT(n)



## Programming the HP 71612 Series Behavior at Power On

[SOURce [1]:]	This is the top layer of the command structure and identifies the pattern generator source sub-system.
PATtern	This is the next layer and is the equivalent of setting the front panel pattern selection field.
PRBS(n), ZSUB(n)	These are the parameters required by the PATtern command keyword.

---

### NOTE

Any optional commands are enclosed in square brackets [ ] and any optional characters are shown in lower case.

A colon indicates a change of level in the command hierarchy. Commands at the same level in the hierarchy may be included in the same command line, if separated by a semi colon.

The bar symbol (I) indicates mutually exclusive commands.

To translate this into a command line you simply follow the same convention, however the command line can be typed in several different ways. This depends on whether longform or shortform is used. The following example gives three possible forms of the command line all of which are perfectly acceptable.

In longform:

```
OUTPUT 718;“SOURCE1:PATTERN:SELECT PRBS7”
```

In shortform:

```
OUTPUT 718;“SOUR1:PATT:SEL PRBS7”
```

With optional commands removed:

```
OUTPUT 718;“PATTERN PRBS7”
```

It can be seen from the examples that longform is the most descriptive form of programming commands in SCPI and will be used for the examples given in this manual.

---

## Behavior at Power On

At power-on, the state of the registers and filters will be:

In normal operation, the enable state of the registers and transition filters will be preserved through a power fail.

## Programming the HP 71612 Series Device/Controller Synchronization Techniques

On virgin power-on, all registers and filters are disabled except: 1) the PON, CME and EXE bits of the Standard Event Status Register and its summary bit in the Status Byte, 2) all the assigned bits of the FAILURE register and its summary bit in the Status Byte. In this way, a user will not be swamped by SRQs. An SRQ will only be generated if the instrument receives invalid commands or queries, or a major hardware failure occurs. The transition filters will be set to allow all conditions and events to pass.

The event registers and the error queue are cleared at each and every power-up.

---

## Device/Controller Synchronization Techniques

### Overlapped Commands

As defined within IEEE Std 488.2-1987 the following commands are overlapped:

```
GATe[:STATe] ON for SINGLE TIMED repetitive periods in the Error Detector.  
EYE: TCENter|EYE:TCENtre ONCE|ON  
EYE ACENter|EYE:ACENtre ONCE|ON  
ELOCation
```

An example of a polled implementation of a clock to data delay alignment is included at the rear of this manual.

An alternative method might involve the configuration of the status reporting structure to cause an SRQ interrupt on one or both transitions of the required bit within the operational status register.

For the overlapped commands listed above, however, a simple and convenient method for holding off the controller until the overlapped operation has completed involves the use of the \*WAI command as shown below in the extract from a Basic Language program where having configured a single gating period of 10 seconds the querying of the bit count result is held off until the gating period has elapsed.

```
INTEGER GatePeriod  
REAL BitCount  
ASSIGN @Bert TO 718  
GatePeriod=10 ! seconds  
OUTPUT @Bert; "SENSE 1 : GATE: MODE SING"  
OUTPUT @Bert; "SENSE1 : GATE : MANNER TIME"  
OUTPUT @Bert;"SENSE1:GATE:PER:TIME "&VAL$(GatePeriod)  
OUTPUT @Bert;"SENSE1:GATE:STATE ON" ! run gating  
OUTPUT @Bert; "*WAI"  
OUTPUT @Bert; "FETCH:SENSE2:BCOUNT?"  
ENTER @DBert ;BitCount
```

## Sequential Commands

Although all commands not listed above as overlapped are sequential, some configuration changes will take a significant time to complete. While querying a pattern disk catalog with MNEM:CAT? is essentially self pacing, the completion of operations like SOURCE1;PATT:UPATn for the selection of disk based user patterns may be conveniently sensed by following such a command with a \*IDN? which, although executing more or less instantaneously, will not begin execution until all preceding commands have been completed. Thus when the instrument returns its identification string it will have completed the configuration of the user pattern.

---

**NOTE**

Many configuration changes will affect the error detector pattern synchronization status and a few of these will incur additional settling time and potentially the need to re-center the detector's clock to data alignment and/or 0/1 threshold level. Refer to the section entitled Overview of Control Sequence between Configuration Changes and the Commencement of Bit Error Measurements, below.

---

## Operation Complete Messages

The following functional criteria are met when an Operation Complete message is generated:

- A SINGLE TIMED gating period has expired.
- The automatic eye time-centering operation has expired.
- The automatic eye amplitude-centering operation has expired.
- An error location capture has occurred.

## Overview of Control Sequence between Configuration Changes and the Commencement of Bit Error Measurements

Whenever the instrument setup is changed, there is a settling time of the hardware and its controlling firmware that can last seconds, or even minutes for some patterns. When the instrument is under remote control it is important to hold off following commands until conditions have settled.

For instance, it would be wrong to start gating whilst the instrument is still settling because there would be a large spurious error count recorded. Similarly, querying the delta error count relating to the unit under test, or instructing an oscilloscope to monitor waveforms should be held off until stability is achieved.

It would not be reliable to use wait statements in the HP-IB control program.

## Programming the HP 71612 Series Device/Controller Synchronization Techniques

A recommended program control flow for the user to achieve this synchronization is given below. It can be used with any combination of BERT modules, and the signal generator source can be either slaved to the pattern generator or independent. It should be regarded as a guideline only.

---

**NOTE** More detailed examples are included in the form of Basic Language Programs in the Program Examples appendix at the rear of this manual. These include details of how to program:

- the detection of clock stabilization following a frequency change,
- how to perform a clock to data delay alignment and
- how to test and gain pattern synchronization.

---

Although the sequence below is shown for a combined pattern generator and error detector system, the steps to omit for generator or detector only systems are self evident. When operating at a single frequency the clock stabilization and clock to data delay alignment steps may also be omitted.

1. Set error detector to manual sync mode.
2. Setup signal generator.
3. Setup pattern generator.
4. Setup error detector.
5. If the clock source is not slaved to the error performance analyzer, then hold off further commands until the pattern generator input clock frequency has stabilized, and the unit is in the correct frequency band. For further details see SENSE6:FREQ? and SENSE6:BAND? generator commands and SENSE2:FREQ? and SENSE2:BAND? detector commands and also examples of there use in the detailed example at the rear of this manual.
6. For reliable bit error measurements following any frequency change it is important to configure the detector to sample the incoming data pattern at the center of the eye i.e. midway between pattern bit transitions. Where the required delay has not previously been established, a clock to data alignment should will find this optimum clock to data delay setting and leave the detector configured this way in addition to measuring the eye-width. For further details see the SENSE1:EYE detector commands and also examples of there use in the detailed example at the rear of this manual. When a successful alignment is performed the synchronisation step below may be omitted otherwise the cause of the alignment failure must be ascertained before continuing.
7. Synchronize the error detector to the incoming pattern. For further details see the SENSE1:SYNC and STAT:QUES:COND? detector commands and also examples of there use in the detailed example at the rear of this manual.
8. If sync is gained then proceed with the testing. If sync has not been achieved then the cause must be established and understood before going any further.

---

**NOTE** Accessing large patterns can take several minutes. Control programs must be prepared for I/O time-outs of this order.

---

## Handling Coupled Parameters

The groups of commands used to configure the electrical levels at the pattern generator's DATA OUT,  $\overline{\text{DATA OUT}}$ , CLOCK OUT,  $\overline{\text{CLOCK OUT}}$ , PARALLEL DATA OUTPUTS and SUBRATE CLOCK OUTPUT have a coupling which makes their use *order sensitive*.

The restrictions on the parameter values that these commands can take and the order in which the commands need to be issued are as follows:

1. Whenever either the external attenuation or termination voltage is configured the output amplitude for that port is set to its minimum value and the high-level is set to  $V_t/2$ . It is therefore almost always a requirement to configure the amplitude and high-level after changing either the attenuation or termination.
2. For DATA OUT,  $\overline{\text{DATA OUT}}$ , CLOCK OUT and  $\overline{\text{CLOCK OUT}}$  whilst the attenuation is set to 0 dB, if the termination voltage is set to 0 Volts, then the maximum value of high-level is  $\pm 1.5$  Volt. If the termination voltage is set to  $-2$  Volts, then the maximum value of the high-level is  $+0.0$  Volts. (For the PARALLEL DATA OUTPUTS and SUBRATE CLOCK OUTPUT the maximum high-level is  $+0.0$  Volts for either termination.)
3. Values of high-level below  $-2$  Volts are restricted according to the value of amplitude. This is shown in the accompanying Figure.
4. If new values of amplitude and high-level are issued, then care needs to be exercised as described below. These are best described with the aid of a diagram.

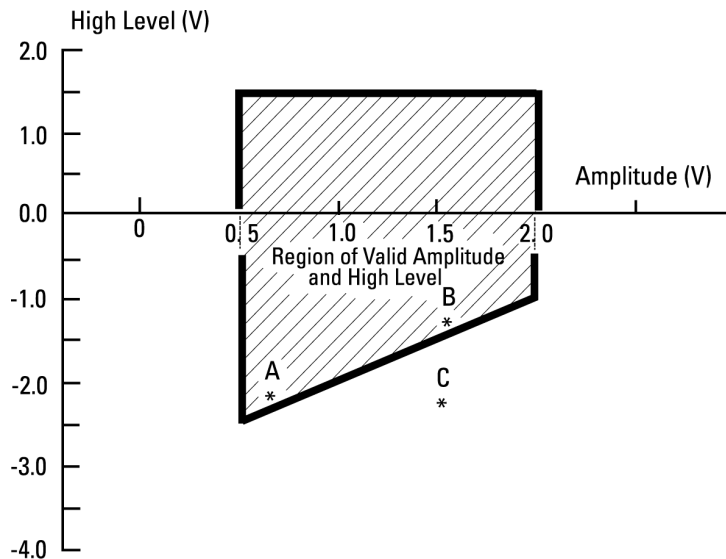
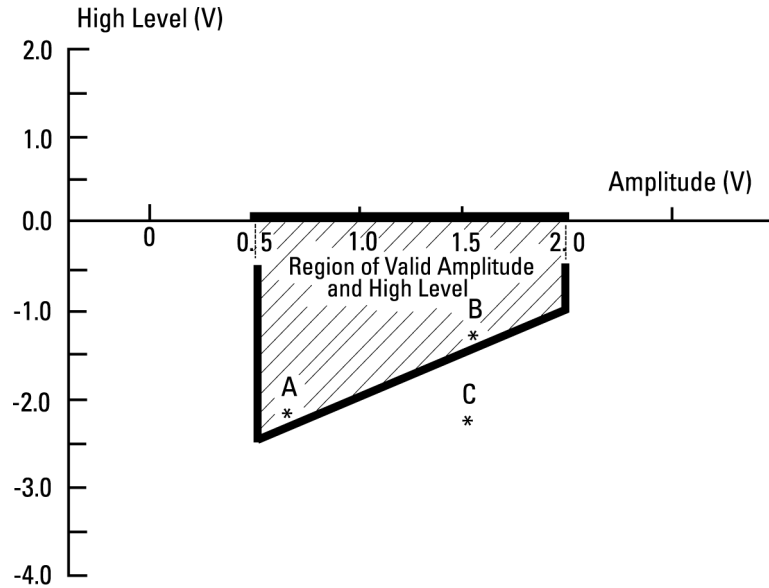

Figure 2-1 Clock/Data Amplitude and High-Level Relationship with 0V Termination

## Programming the HP 71612 Series Handling Coupled Parameters



**Figure 2-2 Clock/Data Amplitude and High-Level Relationship with  $-2V$  Termination**

The Figures shows the region of valid amplitude and high-level. To move from the point A to the point B, for example, requires some care. This arises because, if the amplitude is first moved, followed by the new value of data high-level, then the intermediate state will be at point C and this would generate an error message.

There are two methods of overcoming this problem:

1. The order of issuing the amplitude and high-level may be used to prevent the bottom sloping line being crossed. The algorithm would be:
  - If the new amplitude is greater than the old amplitude, then send the new high-level first, followed by the new amplitude.
  - If the new amplitude is smaller than the old amplitude, then send the amplitude first, followed by the high-level.
2. A dummy move of the high-level to a value between 0V and  $-2.0$  V is followed by the new value of amplitude, followed by the new value of high-level.

## References

1. *HP 70000 MMS Communication Protocol Design Guide* (1988-11) - explains the addressing of MMS modules and the communications links between them.
2. ANSI/IEEE Std 488.1-1987 - *IEEE Standard Digital Interface for Programmable Instrumentation* - defines the electrical behaviour of the HP-IB interface.
3. ANSI/IEEE Std 488.2-1987 - *IEEE Standard Codes, Formats, Protocols, and Common Commands for use with ANSI/IEEE Std 488.1-1987* - defines the allowable syntax of the messages that may be sent over the HP-IB that may be sent over the HP-IB interface.
4. *Standard Commands for Programmable Instruments, SCPI, Syntax and Style - Revision 1.0* - describes the underlying concepts and style guidelines of SCPI.
5. *Standard Commands for Programmable Instruments, SCPI Manual - Version 1990.0* - defines the grammar and vocabulary of SCPI commands.
6. CCITT G.821 (Red Book) - *Error Performance of an International Digital Connection forming part of an Integrated Services Digital Network*
7. CCITT O.151 - *Specification for Instrumentation to Measure Error Performance on Digital Systems*





---

**Interrogating the  
Instrument Status**

# Interrogating the Instrument Status

## HP 71612 Series Status Reporting

### Introduction

This section explains how to use the powerful status reporting features which are contained in the HP 71612 Series.

It explains the structure of the internal registers with examples on how to interrogate them. It also explains the concept of interrupt programming using the Service Request.

The section covers the following topics:

- HP 71612 Series Status Reporting
- Status Register Group Model
- HP 71612 Register Model
- Description of the Status Registers
- Interrupt Programming and using the Service Request

---

### HP 71612 Series Status Reporting

The HP 71612 Series has powerful status and reporting features which give important information about events and conditions within the instrument, for example flag the end of a measurement or perhaps indicate a command error. To access this information requires interrogating a set of registers using Standard Commands for Programmable Instruments (SCPI).

### Internal Registers

The registers contained in the HP 71612 Series are as follows:

Internal Registers
Status Byte
Standard Event Status
Questionable Data Status
Operation Status
Failure Status
Clock Loss

The internal registers are read using a combination of SCPI common commands and SCPI status commands. The method of reading each register is explained in the following sections.

## Generalized Status Register Group Model

SCPI guidelines specifies a register group model which is the building block of the SCPI status reporting system. The SCPI generalized status register group model is shown in Figure 3-1.

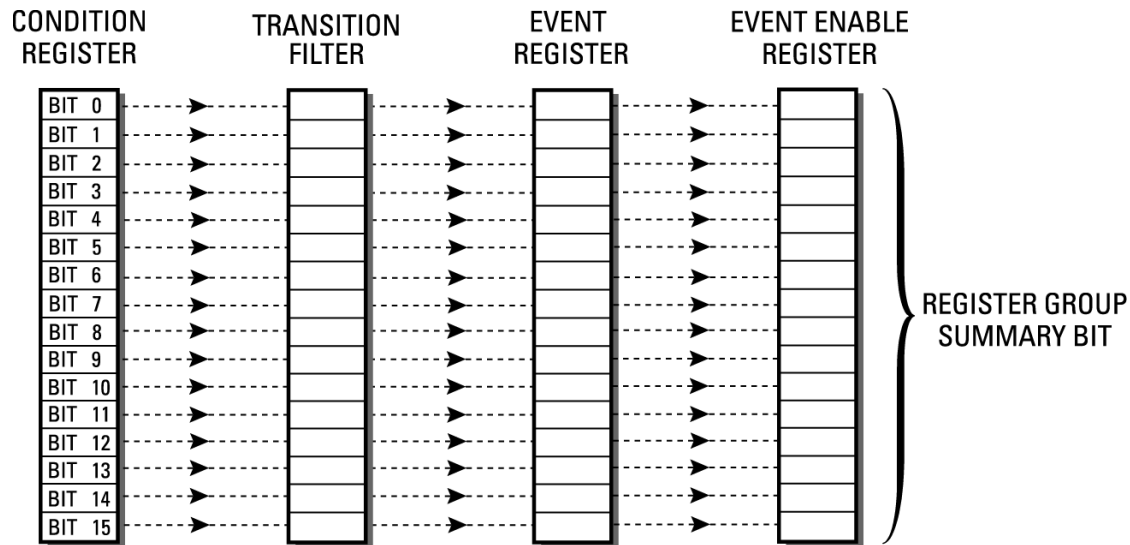

**Figure 3-1 Generalized Status Register Group**

- |                    |   |
|--------------------|---|
| Condition Register | This register monitors the hardware and firmware status of the instrument. There is no latching of conditions in this register, it is updated in real time. |
| Transition Filter  | As the name implies it determines whether positive or negative transitions (true or false) in the Condition register sets the Event register.               |
| Event Register     | This register latches the transient states that occur in the Condition register as specified by the Transition Filter.                                      |
| Enable Register    | The Enable Register acts as a mask on the Event register. It determines which bits in the Event register set the summary bit in the Status Byte.            |

This reporting structure is the basis of generating interrupts that is, service requests, and is explained more fully in the section titled Interrupt Programming and Using the Service Request on page 3-17.

**Interrogating the Instrument Status  
HP 71612 Register Model**

## HP 71612 Register Model

The register model is shown in Figure 3-2.

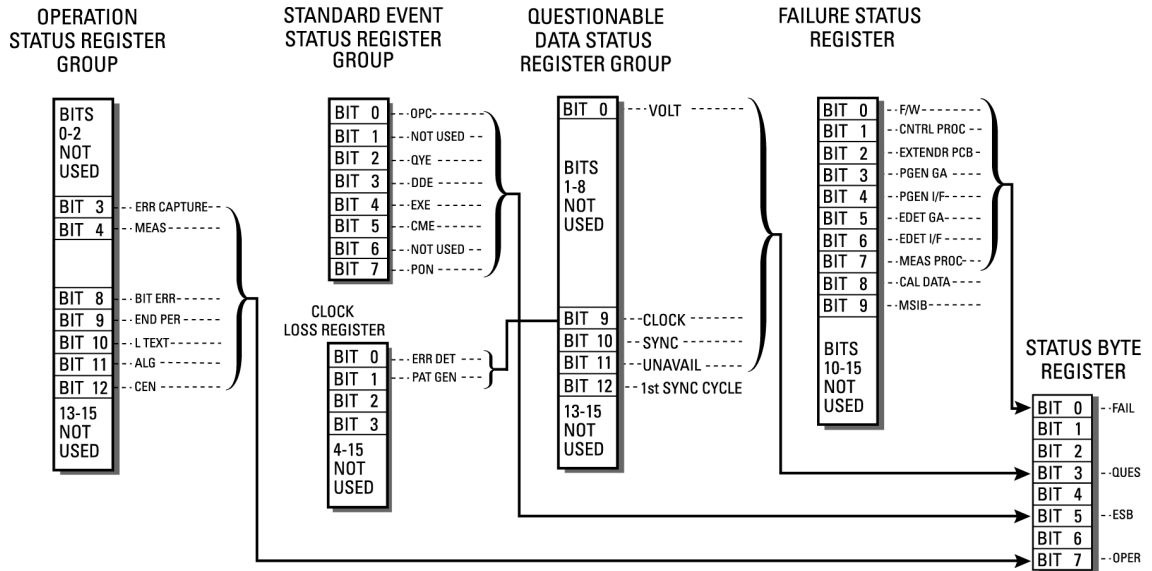

**Figure 3-2 Error Performance Analyzer Register Model**

A full description of the different register groups is given in the following sections.

**Interrogating the Instrument Status**  
**Status Byte Register Group**

## Status Byte Register Group

The Status Byte is the summary register to which the other registers report. Each reporting register is assigned a bit in the status byte register which it can use to summarize its status.

**Table 3-1**                      **Status Byte Register**

Bit #	Mnemonic	Description	Bit Value
0	FAIL	Failure Status register summary bit.	1
1	-	This bit is not used	
2	-	This bit is not used.	
3	QUES	Questionable Data Status register summary bit.	8
4	MAV	Output queue summary bit.	16
5	ESB	Standard Event register summary bit.	32
6	RQS or MSS	SRQ or master status summary bit.	64
7	OPER	Operation Status register summary bit.	128

- FAIL Summary Bit**                      Bit 0, indicates there are bits set in the Failure Status register. This in turn indicates there has been a major hardware failure in the instrument.
- QUES Summary Bit**                      Bit 3, indicates that a bit has been set in the Questionable Data Status register. The bits in the Questionable Data Status register indicate when a signal is of questionable quality.
- MAV Summary Bit**                      Bit 4, is the message available summary bit. This bit remains set until all the output messages are read from the instrument. The instrument stores its messages in an output queue. These messages are read by addressing the instrument to talk and reading the data. The availability of this data is summarized by the MAV bit.
- ESB Summary Bit**                      Bit 5, indicates that a bit in the Standard Event register has been set.
- RQS or MSS Summary bit**                      Bit 6 of the Status Register has two definitions depending of the method used to access the register. If the value of the register is read using the serial poll bit 6 is referred to as the RQS (request service bit) as this is the means used to inform the active controller that the instrument has set the service request control line (SRQ) i.e. interrupted the controller.  
 If the register is read using the \*STB? common query command, then bit 6 is referred to as the master summary bit or MSS bit. It is this bit which indicates the instrument has requested service. The

## Interrogating the Instrument Status Status Byte Register Group

MSS bit is not cleared when the register is read using the \*STB? command. It always reflects the current status of all the instrument's status registers.

OPER Summary bit    Operation Status register summary bit

### Serial Polling

The Status Byte register can be interrogated by serial polling the instrument.

The command for serial polling is SPOLL, as shown in the example program lines below:

```
10 Status_value = SPOLL(718)
20 PRINT Status_value
```

The binary weighted decimal value returned in the variable Status\_value is the value of the Status Byte. The Status Byte gives a summary of the state of the reporting registers.

Another way of reading the value of the Status Byte is by using the \*STB? common query command:

```
10 OUTPUT 718;“*STB?”
20 ENTER 718;Status_value
```

In this case the value returned by the variable Status\_value is exactly the same as the value returned by carrying out a Serial Poll.

### Status Byte Service Request Enable Register

The Service Request Enable register is an 8-bit register which acts as a mask on the Status Byte. The Service Request Enable register is programmed using the SCPI common command \*SRE. When the register is programmed with any given value this determines when the instrument will issue a service request. For a service request to be issued the summary bit in the Status Byte must match the bit in the Service Request Enable Register. See Figure 3-3.

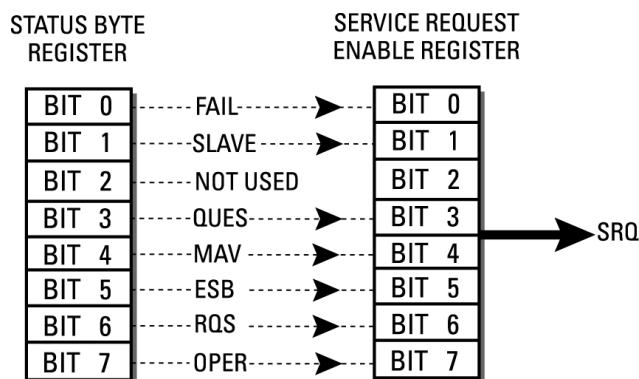

**Figure 3-3      Status Byte Register**

## Interrogating the Instrument Status Status Byte Register Group

For example if bit 3 is set in the Service Request Enable register then the instrument will issue a service request when the corresponding bit is set in the Status Byte, that is bit 3, the Questionable Status register summary bit. See the following example:

```
OUTPUT 718;“*SRE 16”
```

This sets bit 3 of the Service Request Enable register.

---

**NOTE**

For a more detailed description on service request programming and example programs, refer to the section titled Interrupt Programming and Using the Service Request on page 3-17.

---

**Interrogating the Instrument Status**  
**Standard Event Status Register Group**

## Standard Event Status Register Group

The Standard Event Status register group is a 16-bit register group which gives general purpose information about the instrument. It is unique in that it is the only reporting register group programmed using SCPI common commands while the other reporting registers are programmed using the SCPI Status command set.

**NOTE** This register conforms, in part, to the generalized status register model. It comprises of an Event and Enable register, but no Condition register or Transition Filter. Therefore all positive (true) states occurring in this register are latched.

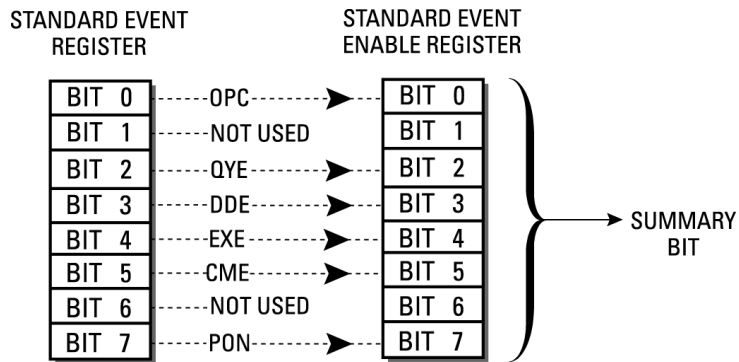

**Figure 3-4 Standard Event Status Register**

The bits in the Standard Event Status register group are defined as follows:

**Table 3-2 Standard Event Status Register**

Bit #	Mnemonic	Description	Bit Value
0	OPC	Operation Complete bit.	1
1	-	Not used	
2	QYE	Query Error bit.	4
3	DDE	Device Dependent Error bit.	8
4	EXE	Execution Error bit.	16
5	CME	Command Error bit.	32
6	URQ	Not used	64
7	PON	Power On bit.	128
8-15	-	These bits are not used	



## Interrogating the Instrument Status

### Standard Event Status Register Group

Operation Complete Bit	The operation complete bit, bit 0, is set in response to the *OPC command if the instrument has completed all its pending operations.
Request Control Bit	This bit is not used in this instrument.
Query Error Bit	The query error bit, bit 2, indicates there is a problem with the output data queue. Either there has been an attempt to read the queue when it is empty or the output data has been lost.
Device Dependent Error Bit	The device dependent error bit, bit 3, is set when an error of some kind has occurred in the instrument.
Execution Error Bit	The execution error bit, bit 4, is set when a command (HP-IB instrument specific) cannot be executed due to an out of range parameter or some instrument condition existing that prevents the execution. For example, the instrument is already set to the wrong range.
Command Error Bit	The command error bit, bit 5, is set whenever the instrument detects an error in the format or content of the program message (usually a bad header, missing argument, or wrong data type etc.).
Power On Bit	The power on bit, bit 7, is set each time the instrument is powered from off to on.

The Standard Event register can be interrogated using the \*ESR? common query command. It is an event register which is cleared after it is read.

```
OUTPUT 718;“*ESR?”  
ENTER 718;Event_reg$  
PRINT Event_reg$
```

Requests the contents of the Standard Event register. The Standard Event Register may also be cleared without having to interrogate it. This is done by using the “\*CLS” command.

### Standard Event Enable Register

The Standard Event Enable register is a 16 bit register which acts as a mask on the Standard Event Status register. It allows one or more event bits in the Standard Event register to set the ESB summary bit, bit 5, in the Status Byte.

For example, if bit 0 is set in the Standard Event Enable register, then, when the OPC bit in the Standard Event register goes true, the ESB summary bit is set in the Status Byte.

The Standard Event Enable register is set using the “\*ESE” command. The following gives an example of setting bit 0, 1 and 2 in the Standard Event Enable register.

```
OUTPUT 718; “*ESE 7”
```

Interrogating the Instrument Status  
Clock Loss Register Group

---

**Clock Loss Register Group**

**Table 3-3**

**Clock Loss Register**

Bit #	Description	Bit Value
0	ERR DET Clock Loss	1
1	PAT GEN Clock Loss	2

**Bit 0:** ERR DET Clock Loss: TRUE when the error detector has detected a clock loss condition.

**Bit 1:** PAT GEN Clock Loss: TRUE when the pattern generator has detected a clock loss condition.

**Interrogating the Instrument Status**  
**Failure Status Register Group**

---

## Failure Status Register Group

The Failure Status register is a 16-bit event register, however in the HP 71612 Series only 10 bits are used. The bits in this register are set to indicate a major hardware element of the instrument has failed.

**Table 3-4** Failure Status Register

Bit #	Description	Bit Value
0	ROM failure.	1
1	RAM failure.	2
2	Non Volatile memory corrupt.	4
3	unused	8
4	PIT failure.	16
5	Pgen interface board	32
6	Edet interface board	64
7	MSIB failure.	128
8	EPR0M failure.	256
9	Pgen Gate Array.	512
10	Edet Gate Array.	1024
11-15	These bits are not used.	

---

**NOTE**

There is no Condition or Enable registers for the Failure Status register. Any failures in the instrument are latched and indicated by this register. The FAIL bit (bit 0) in the Status Byte register is automatically set whenever any bit in the Failure Status register is set. Failures of this type are not recoverable.

---

**Interrogating the Instrument Status**  
**Questionable Data Status Register Group**

## Questionable Data Status Register Group

The Questionable Data Status group is a 16-bit register group. The bits in this register set indicate that a signal is of questionable quality.

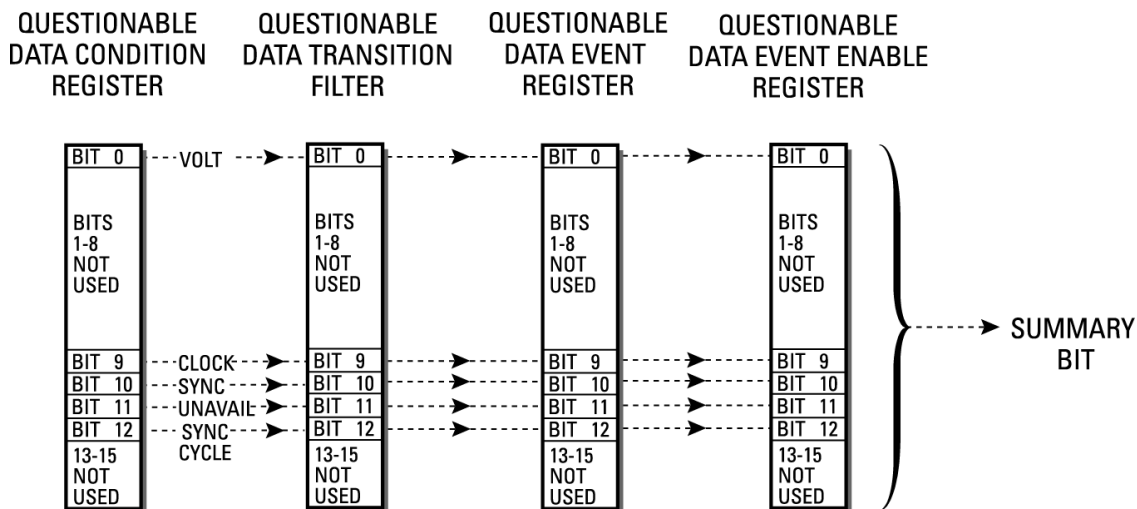

**Figure 3-5 Questionable Data Status Register Group**

The Questionable Data Status register group conforms to the SCPI Status Register model and is defined as follows:

**Table 3-5 Questionable Data Status register group**

Bit #	Mnemonic	Description	Bit Value
0	VOLTage	Indicates data loss	1
1-8	These bits are not used		
9	CLOCK	Clock loss	512
10	SYNC	Sync Loss	1024
11	UNAV	Signal is unavailable	2048
12	Inst. dependent	1st SYNC CYCLE	4096
13-15	These bits are not used		

## Interrogating the Instrument Status Questionable Data Status Register Group

**Bit 12:** 1st SYNC CYCLE: This bit is TRUE when synchronization is lost and when the synchronization search algorithm is in its first cycle through all possible synchronization positions. It becomes FALSE when synchronization is gained, or after all possible synchronization positions have been tried once and the algorithm is about to repeat itself, whichever occurs first.

### Interrogating Register Groups

The Questionable Data Status register group is interrogated using SCPI status commands. The command format consists of:

“Command identifier: Register group identifier: Register title”

### Interrogating the Condition and Event Registers

The Condition and Event registers are interrogated using the :CONDITION? and :EVENT commands. See the following example:

Condition Register Query OUTPUT 718;“STATUS:QUESTIONABLE:CONDITION?”

ENTER 718;Question\_con\_reg

PRINT Question\_con\_reg

Event Register Query OUTPUT 718;“STATUS:QUESTIONABLE:EVENT?”

ENTER 718;Question\_evt\_reg

PRINT Question\_evt\_reg

### Transition Filter

The Transition Filter state is set using the “:PTRANSITION” and “:NTRANSITION” commands. The Transition Filter can be set to pass either positive transitions, negative transitions or both.

---

#### NOTE

The transition filter passes positive transitions by default. To turn this off for the Questionable Data Transition Filter use:

OUTPUT 718;“STATUS:QUESTIONABLE:PTRANSITION 0”

---

**Interrogating the Instrument Status**  
**Questionable Data Status Register Group**

The default setting of the Transition Filter is to pass positive transitions only. To also pass a negative transition on bit 9, that is detect clock gain, from the Condition register to the Event register the command is as follows:

OUTPUT 718;“STATUS:QUESTIONABLE:NTRANSITION 512”

To reset the Transition Filter to pass only positive transitions at bit 9, the command is as follows:

OUTPUT 718;“STATUS:QUESTIONABLE:NTRANSITION 0”

**Questionable Data Event Enable Register**

The Questionable Data Event Enable register acts as a mask on the Questionable Data Event register. It is enabled by sending the command “:ENABLE”. The following example allows one or more event bits in the Questionable Data Event register to set the QUES summary bit in the status byte.

OUTPUT 718;“STATUS:QUESTIONABLE:ENABLE 512”

This enables bit 9, Clock Loss. Whenever a clock loss condition occurs in the condition register the QUES summary bit (bit 3) is set in the Status Byte register.

**Interrogating the Instrument Status  
Operation Status Register Group**

## Operation Status Register Group

The Operation Status register is a 16-bit register group of which only 7 bits are used. This register group conforms to the SCPI register model and gives information about the current operation the instrument is performing. The Operation Status register group is defined as follows:

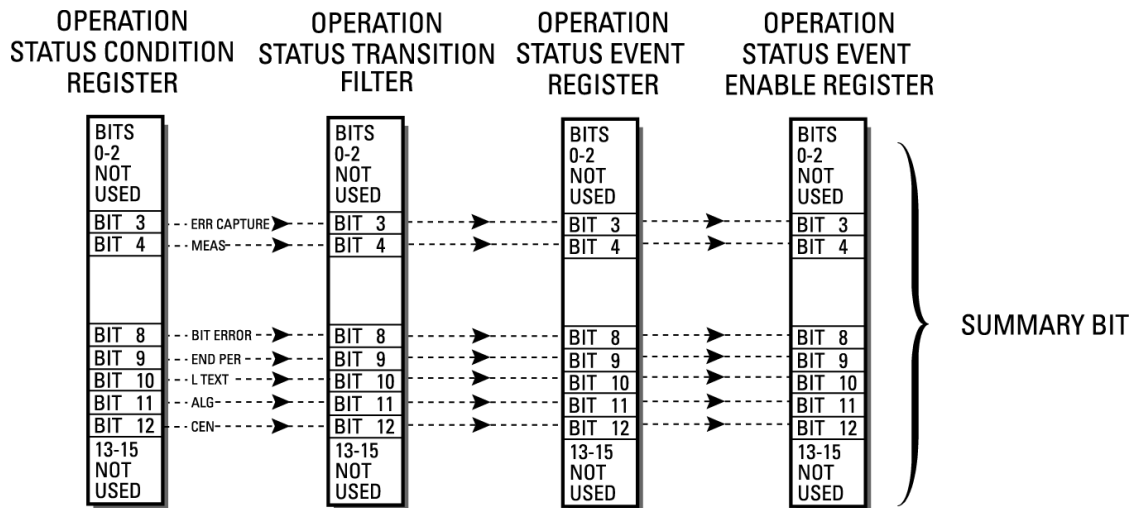

**Figure 3-6 Operation Status Register Group**

The bits in the Operation Status register group are defined as follows:

**Table 3-6 Operation Status Register**

Bit #	Mnemonic	Description	Bit Value
0-2	These bits are not used		
3	ERR CAPTURE	Capturing error location	8
4	MEAS	Measuring (Gating)	16
5-7	These bits are not used		
8	ERR	Bit Error has occurred	256
9	END	End of repetitive measurement period	512
10	LOG	Instrument is logging	1024
11	ALIG	Aligning Clock and Data	2048
12	CENT	Centering Clock and Data	4096
13-15	These bits are not used		

## Interrogating the Instrument Status Operation Status Register Group

### Interrogating the Condition and Event Registers

The Operation Status register group set is interrogated/programmed by the same method as the Questionable Data Status register group, except the register group identifier is changed. The following example gives the commands for interrogating the Condition and Event registers.

Condition Register Query   OUTPUT 718;“STATUS:OPERATION:CONDITION?”

Event Register Query       OUTPUT 718;“STATUS:OPERATION:EVENT?”

### Operation Status Transition Filter

The Operation Status register group Transition Filter value is set in the same way as the Questionable Data Status register group that is, the “PTRANSITION” and “NTRANSITION” commands.

A typical example would be as follows:

OUTPUT 718;“STATUS:OPERATION:PTRANSITION 8”

This sets the Transition Filter to pass a positive transition from the Condition register at bit 3.

---

**NOTE**

The transition filter passes positive transitions by default. To turn this off for the Operation Status Transition Filter use:

OUTPUT 718;“STATUS:OPERATION:PTRANSITION 0”

---

### Operation Event Enable Register

The Operation Event Enable register is enabled by sending the SCPI command shown in the example below. This allows one or more event bits in the Operation Status register to set the OPER summary bit in the Status Byte register.

OUTPUT 718;“STATUS:OPERATION:ENABLE 512”

If bit 9 is set in the Operation Event Enable register and the END PERIOD bit in the Operation Event register goes true, then the OPER bit is set in the Status Byte.



## **Interrupt Programming and Using the Service Request**

The method of interrogating the reporting registers is to read the register using SCPI status commands. This method is perfectly adequate for most applications, however should you wish to detect when a particular event occurs, this would require the register to be continually polled. This problem is solved using interrupts.

Interrupts allow the instrument to interrupt the controller when a particular register has changed. The controller can then suspend its present task, service the instrument and then return to its initial task. It is more convenient and more efficient to get the instrument to issue a service request (SRQ) when an event or condition occurs, rather than continually poll the instrument.

The basic steps involved in generating a service request (SRQ) are as follows:

- Decide which particular event in a given status register you wish to trigger the service request.
- Set the Transition Filter to pass the chosen transition of that event.
- Set the Enable register from that register group to pass that event to set the summary bit in the Status Byte register.
- Set the Status Byte Enable register to generate an SRQ on the chosen summary bit being set.

The process is best explained by looking at an actual example. The following example generates an SRQ from an event in the Operating Status group.

### **Generating a Service Request from the Operating Status Register**

The following example causes the error detector to generate a service request at the end of a measurement period using bit 4 of the Operation Status. See Figure 3-7 on page 3-18.

**Interrogating the Instrument Status**  
**Interrupt Programming and Using the Service Request**

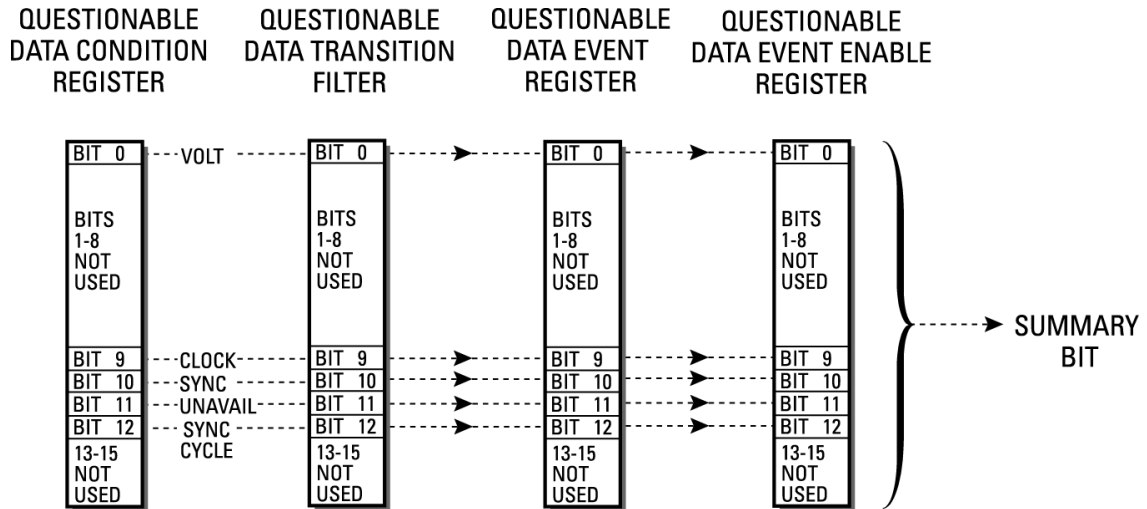

**Figure 3-7 Service Request Illustration**

**NOTE** The SRQ enable bit, bit 6, of the Status Byte is the master status summary bit and will automatically be set on the occurrence of a service request.

The basic steps involved in setting the instrument to generate this service request are as follows:

- Step 1 Set the Transition Filter to pass the chosen condition, either when it is true (positive) or when it is false (negative). The default value of the Transition Filter is that all positive (true) conditions are passed.
- Step 2 Program the Operation Enable Event register to allow bit 4 in the Event register to set the summary bit in the Status Byte register.
- Step 3 Program the Service Request Enable register to generate a service request when the Operation Status summary bit (OPER) is set in the Status Byte register.

Translating these three steps into SCPI command lines it appears as follows:

Using an INTERRUPT to determine when the Error Detector has completed an operation (a DATA/CLOCK alignment in this example):

```
10 CLS
20 Err-det=718
30 Escape=0
40 OUTPUT Err_det"STATUS:OPERATION:PTRANSITION 0"
```

**Interrogating the Instrument Status**  
**Interrupt Programming and Using the Service Request**

```
50 OUTPUT Err_det"STATUS:OPERATION:NTRANSITION 6144"  
60 OUTPUT Err_det"STATUS:OPERATION:ENABLE 6144"  
70 OUTPUT Err_det"*SRE 128"  
80 ENTER Err-det"SENSE1:EYE:TCENter ON"  
90 ON INTR 7 CALL Servroutine( Escape )  
100 ENABLE INTR 7,2  
110 REPEAT  
120 PRINT "Data/Clock Aligning"  
130 UNTIL Serv=1  
140 PRINT "Data/Clock Aligned"  
150 END  
160 SUB Servroutine( Serv )  
170 Serv=1  
180 PRINT "Interrupt received"  
190 SUBEND
```

Note that it is necessary to explicitly turn positive transitions OFF when you are setting up the SRQ conditions (line 40). Lines 50 and 60 cause the STB bit 7 to be set only if bits 11 or 12 are set in the OPERATION register. When both these bits go low, the Data/Clock alignment is completed and an SRQ is generated.

Use the interrupt occurrence to proceed to the next part of the program.

The time that bit 7 stays high for in the SRE register depends on how long the TCENter command takes to execute and depends on initial parameter values (phase delay and data rate for example). For a  $2^{23}-1$  PRBS @ 3 Gb/s, 0.5 volts pp, the time is about 10 seconds for TCEN on the unit tested.



---

**Transferring USER  
Patterns over HP-IB**

## Transferring USER Patterns over HP-IB Pattern Upload/Download Example

### Introduction

This section explains some of the subtleties of transferring USER Patterns over HP-IB to and from the HP 70843. A BASIC program example is used to illustrate these and hints and tips are given for using other programming languages.

The program example is for separate HP 70843 Pattern Generators and Error Detectors (Options UHG and UHH) but can be adapted for the HP 70843 Error Performance Analyzer (Option UHF).

---

### Pattern Upload/Download Example

This program reads the User Pattern Label (line 100) from the Pattern Generator, then the pattern length (line 110). It then uploads the pattern data into an Array (line 120) after removing the Header information. The program then re-constructs the Header (line 130) and sends it to the Error Detector before downloading the pattern data from the array (line 140).

```
10 REAL Upatbitlen,Maxupatbits,Upatbytelen,Byteno,Rowbyteno
20 INTEGER Bitsperbyte,Rowno,Ed,Pg
30 DIM Upatlabel$(14),Header$(10)
40 CLEAR SCREEN
50 Ed=717
60 Pg=718
70 Bitsperbyte=8
80 INTEGER Upat(720,720)
90 !
100 GOSUB Readupatlabel
110 GOSUB Readupatlength
120 GOSUB Uloadupat
130 GOSUB Makeblockhdr
140 GOSUB Dloadupat
150 STOP
160 Readupatlabel:!
170 OUTPUT Pg;"SOURCE1:PATT:UPAT0:LABEL?"
180 !WAIT 2
190 ENTER Pg;Upatlabel$
200 DISP Upatlabel$
210 WAIT 1
220 RETURN
```

## Transferring USER Patterns over HP-IB Pattern Upload/Download Example

```
230  !
240 Readupatlength: !
250     OUTPUT Pg;"SOURCE1:PATT:UPAT0:LENGTH?"
260     ENTER Pg;Upatbitlen
270     DISP Upatbitlen
280     WAIT 1
290     RETURN
300  !
310 Uloadupat: !
320 OUTPUT Pg;"SOURCE1:PATT:FORMAT PACK, "&VAL$(Bitsperbyte)
330 OUTPUT Pg;"SOURCE1:PATT:UPAT0:DATA?"
340 ENTER Pg USING "#,A,D";Line$,Nooflendigits
350     Upatbytelen=0
360     FOR Lendig=1 TO Nooflendigits
370         ENTER Pg USING "#,D";Num
380         Upatbytelen=10*Upatbytelen+Num
390     NEXT Lendig
400     DISP "no of upat data block bytes = ";Upatbytelen
410     Rowno=0
420     Rowbyteno=0
430     FOR Byteno=0 TO Upatbytelen-1
440         ENTER Pg USING "#,B";Upat(Rowno,Rowbyteno)
450         IF (Rowbyteno>=SQRT(Upatbytelen)) THEN
460             Rowno=Rowno+1
470             Rowbyteno=0
480         DISP "Uploaded";INT(100*(Rowno/SQRT(Upatbytelen))); " % of pattern"
490         ELSE
500             Rowbyteno=Rowbyteno+1
510         END IF
520     NEXT Byteno
530     DISP "Uploaded Pattern"
540     RETURN
550 Makeblockhdr: !
560 Header$="#"&VAL$(LEN(VAL$(Upatbytelen))&VAL$(Upatbytelen)
570     RETURN
580 Dloadupat: !
590 OUTPUT Ed;"SENSE1:PATT:UPAT0:LABEL "&Upatlabel$
600 OUTPUT Ed;"SENSE1:PATT:UPAT0:USE STR"
610 OUTPUT Ed;"SENSE1:PATT:UPAT0:LENGTH "&VAL$(Upatbitlen)
620 OUTPUT Ed;"SENSE1:PATT:FORMAT PACK, "&VAL$(Bitsperbyte)
```

## Transferring USER Patterns over HP-IB Pattern Upload/Download Example

```
630 OUTPUT Ed USING "#,K";"SENSE1:PATT:UPAT0:DATA "&Header$
640     Rowno=0
650     Rowbyteno=0
660     FOR Byteno=0 TO Upatbytelen-1
670         OUTPUT Ed USING "#,B";Upat(Rowno,Rowbyteno)
680         IF (Rowbyteno>=SQRT(Upatbytelen)) THEN
690             Rowno=Rowno+1
700             Rowbyteno=0
710             DISP "Downloaded";INT(100*(Rowno/SQRT(Upatbytelen)));"% of pattern"
720             ELSE
730                 Rowbyteno=Rowbyteno+1
740             END IF
750     NEXT Byteno
760     DISP "Pattern Downloaded to Error Detector"
770     RETURN
780     END
```

### Some General Hints

1. See pages 5-3 to 5-10 of this Programming Manual (71600-90011). These explain the commands and data formatting used for transferring patterns to and from the Pattern Generator and Error Detector.
2. Pattern DATA is stored in binary *NOT* ASCII in the Pattern Generator and Error Detector.
3. The uploaded (and downloaded) pattern includes a Header string as follows:  
#ABBBDDDD..., where:  
# is the ASCII character which defines the start of the Header.  
A is an integer (in the range 1 to 9) whose value is the number of B characters.  
BBB is the value of the pattern length in bits.  
DDD... is the BINARY data of the pattern.  
So an uploaded (downloaded) pattern 32768 bits long would look like:  
#532768DDDDDD...
4. When uploading patterns from UPAT0 (the edit buffer in the PG or ED), the data should be read into an Array. See lines 440 to 470 in the IBASIC example, specifically line 440.

---

#### NOTE

A two-dimensional array is used in this example, this makes displaying the data easier. Also in some programming languages/computers it may be necessary to use more than one dimension due to pattern size (up to 8 Mbits or 1Mbytes) due to memory limitations.

---

5. PACK 8 format saves memory and is quicker to load/save.



## Transferring USER Patterns over HP-IB Pattern Upload/Download Example

6. Notice the way the header string is ENTERed during pattern Upload in lines 330 to 390 of the example. The ENTER USING “#,D” construct reads only the first two characters in the pattern string (# and A, see 3 above) and the program assigns the “A” to a pattern length variable (line 380).  
The FOR NEXT loop in lines 460 to 490 then ENTERs the pattern length digits and converts them to a value for pattern length.
7. The BINARY Pattern DATA is loaded into the Upat ( ) array in lines 410 to 530.
8. The header string must be constructed before downloading a pattern (line 550 of the example). This is sent in line 630.
9. Pattern DATA is sent in the FOR NEXT loop in lines 640 to 760. The OUTPUT USING “#,B” construct in line 670 allows data to be sent to the Error Detector (or Pattern Generator) one byte at a time.

Here are tips for other coding languages:

### Visual Basic

Here is an excerpt from a Visual Basic Program:

```
For j = 1 To 32768
Word$ = Word$ + Chr$(btX(j))
Next j

Call Send(det%, "PATT:FORM PACK,1" & Chr$(10)) Call Send(det%, "PATT:UPAT0 32768"
& Chr$(10))

Call Send(det%, "PATT:UPAT0:DATA #532768" & Word$ & Chr$(10))
```

This example is with Visual Basic 4 where the binary is obtained by using Chr&(0) or Chr\$(1) function.

### Labview

This can be used for both data FORMAT packing types (1 bit per byte and 8 bits per byte).

The trick for Labview is to use the “Flatten to String” command.

1. Make the command and Header string.
2. For packed data (8 bits per byte), create an array (Integer8 type) formatted as binary or hex (8 binary digits or 2 hex digits per array position).
3. For unpacked data (1 bit per byte), create an array of binary 1s and 0s.
4. Use “Flatten to String” repeatedly and concatenate each of these to form a train of bytes. Concatenate this with the header created in step 1 above.



---

**System Command  
Reference Section**

## Pattern Configuration

In an instrument containing pattern generator and error detector modules the pattern configuration in the generator and detector is coupled and hence need only be configured once using either the SOURCE1:PATT or SENSE1:PATT commands. In generator only instruments the SOURCE1:PATT form must always be used while in detector only instruments the SENSE1:PATT form is mandatory.

This coupling of the pattern configuration includes configuration of alternating user patterns although the detector will always use pattern B as the reference for comparison to the incoming data.

The coupling does not apply in 2 functional groups; control of the generator's switching between pattern A and pattern B of an alternating user pattern (configured with the SOURCE1:PATT:APCH commands) and control of the generator's error addition functions (via the SOURCE1:PATT:EADD commands).

In all other cases, within the provisos of the preceding paragraphs, the SOURCE1 and SENSE1 root keywords may be used interchangeably when controlling the instrument's pattern configuration.

### [SOURCE[1]:]PATTERN[:SElect] <character data>

This node defines the type of pattern being generated. The <character data> is one of:

PRBS<n>            <n> = 7,10,15,23 or 31  
ZSUBstitut<n><n> <n> = 7,10,11, or 13  
MDENSITY<n>      <n> = 7,10,11, or 13  
UPATtern<n>      <n> 0,1,2,3,4,5,6,7,8,9,10,11, or 12

ZSUBstitut is a contraction of the phrase: *Zero SUBstitution* and is used for defining patterns in which a block of bits is replaced by a block of zeros.

MDENSITY is a contraction of the phrase: *Mark DENSITY* and is used for defining a pattern in which the density of marks may be set by the user.

UPATtern<n> is a contraction of the phrase: *User PATtern* and is used to define the contents of a pattern store. The value <n> must be in the range 0 through 12.

The commands under this node affect the storage of information as defined as follows:

<n> = 0            Current pattern  
<n> = 1 thru 4    Non-volatile RAM storage  
<n> = 5 thru 12   Disk storage

**System Command Reference Section**  
**Pattern Configuration**

Note that if a user pattern is selected and the [:SELECT]? command is used, then the response is "UPAT". The particular value of <n>, indicating the NV-RAM or disk store from which the pattern originated, is not present.

The \*RST selection is PRBS23.

**[SOURCE[1]:]PATTERN:ZSUBstitut[:ZRUN] <numeric value>**

This is a contraction of the phrase: *Zero RUN*, and is the length, in bits, of the longest run of zeros in the pattern. The zeros that are added for the Zero Substitution function replace the bits that immediately follow this longest run of zeros and the length of the overall block of zeros is the value set by the ZRUN command. The range of values is:

<b>MINimum</b>	<i>The length of the longest run of zeros in the unmodified pattern. (eg for a pattern this value is 7.)</i>
<b>MAXimum</b>	<i>The length of the pattern minus one.</i>

The \*RST selection is 13.

**[SOURCE[1]:]PATTERN:MDENSITY [:DENSITY] <numeric value>**

Sets the density of marks in the output pattern. The mark density may be varied in eighths, from one to seven eighths, (but excluding three eighths and five eighths).

The \*RST selection is four eighths.

**[SOURCE[1]:]PATTERN:UPATTERN<n> [:LENGTH] <numeric value>**

This command sets the length of the pattern that is to be generated. When an alternate user-defined pattern is selected, the :LENGTH refers to each half of the pattern. The pattern length has the following constraints:

1. 1 bit to 32 kbits in 1-bit steps,
2. 32 kbits to 64 kbits in 2-bit steps,
3. 64 kbits to 128 kbits in 4-bit steps,
4. 128 kbits to 256 kbits in 8-bit steps,
5. 256 kbits to 512 kbits in 16-bit steps,
6. 512 kbits to 1 Mbits in 32-bit steps,
7. 1 Mbit to 2 Mbits in 64-bit steps,
8. 2 Mbits to 4 Mbits in 128-bit steps,
9. 4 Mbits to 8 Mbits in 256-bit steps

The \*RST command leaves this selection unchanged.

---

**NOTE**                      Accessing large patterns can take several minutes. Control programs must be prepared for I/O time outs of this order.

---

**System Command Reference Section**  
**Pattern Configuration**

**[SOURCE[1]:]PATTERN:UPATTERN<n>:LABEL <string>**

Defines a character string of up to 14 characters that is associated with the pattern. This is to make it easy for the user to comprehend the purpose of the particular pattern without having to refer to a lookup table.

The character data values of MINimum, MAXimum and DEFault are not defined for the label.

The **\*RST** command leaves this selection unchanged.

**[SOURCE[1]:]PATTERN:UPATTERN<n>:USE STRAIGHT|APATTERN**

Defines the use of a user-defined pattern. When STRAIGHT is selected the whole of the pattern is repeatedly output. When APATTERN is selected the pattern is considered to be composed of two halves. The “:APCHANGE” command controls how these two halves are output.

The “USE” command also resets the length of selected pattern store to one.

For user-patterns used in the *STRAIGHT* mode, the recommended sequence of issuing commands is:

SOURCE1:PATTERN:UPATTERN<n>:USE	STRAIGHT
SOURCE1:PATTERN:UPATTERN<n>[:LENGTH]	<numeric value>
SOURCE1:PATTERN:UPATTERN<n>:DATA	<block data>
SOURCE3:TRIGGER:UPATTERN<n>	<numeric value>

For user-patterns used in the APATTERN mode, the recommended sequence of issuing commands is:

SOURCE1:PATTERN:UPATTERN<n>:USE	APATTERN
SOURCE1:PATTERN:UPATTERN<n>[:LENGTH]	<numeric value>
SOURCE1:PATTERN:UPATTERN<n>:DATA	A,<block data>
SOURCE1:PATTERN:UPATTERN<n>:DATA	B,<block data>
SOURCE3:TRIGGER:UPATTERN<n>	ABCHANGE SOPattern

The **\*RST** command leaves this selection unchanged.

**[SOURce[1]:]PATtern:UPATtern <n>:DATA [A|B,] <block\_data>**

Sets the bits of the pattern. The bits are sent as an arbitrary block diagram data element. The data may be sent 1 bit/byte or 8 bits/byte, under the control of the SOURce1:PATT:FORMAT[:DATA] command. If 1 bit/byte is selected numeric values of either binary 1 or binary 0 only are allowed. If 8 bits/byte is selected the left-most bit of the first byte received forms the first bit of the pattern.

If “SOURce1:PATT:UPAT<n>:USE APATtern” is selected, then the first parameter indicates which half pattern is to receive the data. If “SOURce1:PATT:UPAT<n>:USE STRAight” is selected, either “A” or no first parameter are acceptable.

The length of the <block data> embedded in the header refers always to the length in bytes irrespective of the current setting of the [:DATA] PACKed, <numeric value> command.

The character data values of MINimum, MAXimum and DEFault are not defined for the data.

To be consistent with the behavior of the pattern editor, more bits may be sent than are specified by the “LENGth” command, in which case the extra bits will be ignored and will not appear as part of the pattern. If the pattern length is subsequently extended the extra bits are filled with zeros. If fewer bits than specified by the “LENGth” command are sent, then the bits in the store beyond the length sent remain unchanged.

The pattern stores 1 through 4 have an overall length of 8192 bits, and pattern store 0 and 5 through 12 have an overall length of 4,194,304 bits.

The following rules apply:

1. If ‘PATtern:FORMat PACKed,1’ is selected and data is sent with the ‘:UPATtern:DATA’ command, then:  
block length = pattern length
2. If ‘PATtern:FORMat PACKed,1’ is selected and data is sent with the ‘:UPATtern:IDATa’ command, then:  
block length = number of relevant bits in block  
(start bit + block size) <= pattern length  
block size >= 1
3. If ‘PATtern:FORMat PACKed,8’ is selected and data is sent with the ‘:UPATtern:DATA’ command, then:  
block size = ((pattern length – 1) DIV 8) + 1
4. If ‘PATtern:FORMat PACKed,8’ is selected and data is sent with the ‘:UPATtern:IDATa’ command, then:  
block size = ((number of relevant bits in block – 1) DIV 8) + 1  
(start bit + block size) = ((pattern length – 1) DIV 8 + 1) \* 8  
block size >= 1

## System Command Reference Section

### Pattern Configuration

An arbitrary block program data element is a method of sending large quantities of data from a controller to an instrument. It comes in two forms; an *indefinite length* format when the length of the transmission is not known, and a *definite length* format when the length is known. In the application here, the *definite length* format is used.

A definite length arbitrary block program data element is composed of two parts; a header and the data itself. The header is made up from three parts:

1. The first part is the ASCII character #.
2. The second part is a single non-zero ASCII digit. The magnitude of this digit equals the number of digits in the third part of the header.
3. The third part is composed of between 1 and 9 ASCII digits. The value of these digits taken together as a decimal integer equal the number of 8-bit data bytes which follow.

The data part is composed of a number of 8-bit data bytes.

As an example, if a user-pattern of length 7986 bits is to be set up, then the header would be #47986.

The **\*RST** command leaves this selection unchanged.

**[SOURCE[1]:]PATTERN:UPATTERN<n>:IDATA [A|B,] <start\_bit>, <length\_in\_bits>,<block\_data>**

This command is similar to the :DATA command. The header is short for Incremental Data and the command is used to download just part of a user-defined pattern.

If “SOURCE1:PATT:UPAT<n>:USE APATTERN” is selected, then the first parameter indicates which half pattern is to receive the data. If “SOURCE1:PATT:UPAT<n>:USE STRAIGHT” is selected, either “A” or no first parameter are acceptable.

The length of the <block data> embedded in the header refers always to the length of the data in bytes.

The first parameter defines the starting position within the overall pattern of the first bit of the transmitted pattern. The first bit is counted as bit zero. The second parameter defines how many bits are to be transmitted and the third parameter provides the data itself.

The query form of the command is of the format “:IDATA? <start bit>,<length in bits>”. The second parameter defines the length (in bits) of the data block to be output.

**[SOURCE[1]:]PATTERN:UPATTERN<n>:LMODIFIED? <string>**

This query only command returns the date and time a user pattern was last modified.



### Example 1 - Use of the :DATA command

Set user-defined pattern store 5 to a length of 9 bits. Let the new data bits be 1, 0, 0, 1, 1, 0, 1, 1, 1 (binary). Then query the contents of this pattern store.

Method 1: using data packed 1 bit per byte.

```
PATT:FORM          PACK,1
PATT:UPAT5         9
PATT:UPATS:DATA   #19<data>
```

where

0 = the start of the header

1 = the number of decimal digits to follow forming the length

9 = the length of the data block that follows

<data> = 9 data bytes containing binary 00000001

```
00000000
00000000
00000001
00000001
00000000
00000001
00000001
00000001
```

```
PATT:UPAT5:DATA?
would return      #19<data>
```

where

# = the start of the header

1 = the number of decimal digits to follow forming the length

9 = the length of the data block that follows

<data> = 9 data bytes containing binary 00000001

```
00000000
00000000
00000001
00000001
00000000
00000001
00000001
00000001
```

System Command Reference Section  
Pattern Configuration

Method 2: using data packed 8 bits per byte.

```
PATT:FORM          PACK,8
PATT:UPAT5         9
PATT:UPATS:DATA   #12<data>
```

where

# = the start of the header

1 = the number of decimal digits to follow forming the  
length

2 = the length of the data block that follows

<data> = 2 data bytes containing binary 10011011 and  
1xxxxxxx

```
PATT:UPAT5:DATA?
would return    *12<data>
```

where

\* = the start of the header

1 = the number of decimal digits to follow forming the  
length

2 = the length of the data block that follows

<data> = 2 data bytes containing binary 10011011 and  
10000000

## Example 2: Use of the :IDATa command

Update 9 bits of store number 5 starting at bit 3. Let the new data bits be 1, 0, 0, 1, 1, 0, 1, 1, 1 (binary). Then query these 9 bits.

Method 1: using data packed 1 bit per byte.

```
PATT:FORM          PACK,1
PATT:UPAT5:IDAT   3,9,#19<data>
```

where

3 = the start bit

9 = the number of bits

# = the start of the header

1 = the number of decimal digits to follow forming the  
length

9 = the length of the data block that follows

```
<data> = 9 data bytes containing binary 00000001
                                           00000000
                                           00000000
                                           00000001
                                           00000001
                                           00000000
                                           00000001
                                           00000001
                                           00000001
                                           00000001
```

```
PATT:UPAT5:IDAT? 3,9
would return      #19<data>
```

where

# = the start of the header

1 = the number of decimal digits to follow forming the  
length

9 = the length of the data block that follows

```
<data> = 9 data bytes containing binary 00000001
                                           00000000
                                           00000000
                                           00000001
                                           00000001
                                           00000000
                                           00000001
                                           00000001
                                           00000001
                                           00000001
```

System Command Reference Section  
Pattern Configuration

Method 2: using data packed 8 bits per byte.

```
PATT:FORM          PACK,8
PATT:UPAT5:IDAT    3.9,#12<data>
```

where

3 = the start bit  
9 = the number of bits  
# = the start of the header  
1 = the number of decimal digits to follow forming the length  
2 = the length of the data block that follows  
<data> = 2 data bytes containing binary 10011011 and  
1xxxxxxx

```
PATT:UPATS:IDAT?  3,9
would return      #12<data>
```

where

# = the start of the header  
1 = the number of decimal digits to follow forming the length  
2 = the length of the data block that follows  
<data> = 2 data bytes containing binary 10011011 and  
10000000

**[SOURCE[1]:]PATTERN:FORMAT[:DATA] PACKed,<numeric value>**

This command controls the format of data transfer for the SOURCE1:PATTERN:UPATTERN<n>:DATA and SOURCE1:PATTERN:UPATTERN<n>:IDATA commands.

It specifies the number of bits within each byte of the <block data> parameter used with those commands. The First parameter must be *PACKed*. The <numeric value> parameter may be set to either 1 or 8.

The \*RST selection is "PACKed,1".

## Control of User Pattern A to B Changeover in the Generator

APCHange is a contraction of the phrase *alternate pattern change* and is used to control how user-defined patterns are output when set to be used as alternate patterns.

### [SOURCE[1]:]PATTERN:APCHange:SOURce EXTernal|INTernal

This command control the source of control for the alternate pattern output. When EXTernal is selected the pattern is controlled by the rear-panel Auxiliary Input socket. When INTernal is selected the pattern is controlled by the user, either from the front-panel or from HP-IB using other commands from within this group.

The \*RST selection is “EXTernal”.

### [SOURCE[1]:]PATTERN:APCHange:MODE ALternate|ONEShot

This command controls the mode of operation of the alternate pattern output. If ALternate is selected and the source is set to EXTernal, then the polarity of the signal at the Auxiliary Input socket governs which half of the pattern is output. If the source is set to INTernal, then the :APCHange:SElect command control which half of the pattern is output.

If the MODE is set to ONEShot and the source is set to EXTernal, then a single insertion of a number of instances of half B of the pattern is output for each rising edge of the Auxiliary Input. If the source is set to INTernal, then the :APCHange:IBHalf command is used to insert one instance of half B of the pattern. The number of half B instances is equal to the smallest integral multiple of the pattern length that divides exactly by 256.

The \*RST selection is “ALternate”.

### [SOURCE[1]:]PATTERN:APCHange:SElect AHALf|BHALf

This command controls whether half A or half B of the alternate pattern is output. It is valid only when :APCHange:SOURce is set to INTernal and :APCHange:MODE is set to ALternate.

The \*RST selection is “AHALf”.

### [SOURCE[1]:]PATTERN:APCHange:BHaIf ONCE:

This command is short for *Insert B Half*. It causes the single insertion of a number of instances of half B of the alternate pattern to be inserted. It is valid only when :APCHange:SOURce is set to INTernal and :APCHange:MODE is set to ONSHot. It is an event command, and as such has no query form. The number of half ‘B’ insertions is equal to the smallest integral multiple of the pattern length that divides exactly by 256.

## Error Addition in the Pattern Generator

### **[SOURCE[1]:]PATTERN:EADDITION ONCE|<boolean>**

This is a contraction of the phrase: *Error ADDition* and is used to control the addition of errors into the generated pattern. The parameter ONCE causes a single bit error to be added to the pattern. It also turns off the constant rate error addition.

A boolean parameter enables/disables the addition of errors at a fixed rate.

The \*RST selection is OFF.

### **[SOURCE[1]:]PATTERN:EADDITION:SOURCe EXTernal|FIXed**

This command controls the source of injected errors. When set to EXTERNAL (and :EADDITION[:STATe] is ON), each pulse at the External Errors socket causes an error to be added to the data stream. When set to FIXed (and :EADDITION[:STATe] is ON), repetitive errors are internally added to the data stream. The rate of error addition is controlled by the :EADDITION:RATE command.

The \*RST selection is “FIXed”.

### **[SOURCE[1]:]PATTERN:EADDITION:RATE <numeric value>:**

This command controls the rate of internal, fixed error addition. Values between 1E-3 and 1E-9 in decade steps are permitted.

## User Pattern Disk Operations

This subsystem is used for controlling the floppy disk used as mass memory with the instrument. It is recommended that a floppy disk is reserved for sole use by the HP 70843A.

### **MMEMory:INITialize**

The INITialize command is used to initialize the floppy disk mass storage medium.

This command is an event and has no **\*RST** condition.

### **MMEMory:DELeTe <file name>**

The DELeTe command removes a file from the floppy disk. The <file name> parameter specifies the file name to be removed. It is a string parameter. File names are 'HPPATxx.DAT', where xx ranges from 05 through 12. For example to delete disk pattern 7. the command would be "MMEM:DEL 'HPPAT 07.DAT'".

This command is an event and has no **\*RST** condition or query form.

### **MMEMory:CATalog? <NR3>,<NR3> { ,<file entry> }**

The CATalog? command is query-only and returns information on the current contents and state of the floppy disk. Upon a CATalog? query, the instrument reads the floppy disk and returns its directory information. The information returned is composed of two numeric parameters followed by as many strings as there are files in the directory list. The first parameter indicates the total amount of storage currently used in bytes. The second parameter indicates the total amount of storage available, also in bytes. The <file entry> is a string. Each <file entry> indicates the name, type and size of one file in the directory list:

<file name>,<file type>,<file size>

The <file size> is returned in bytes. The number of <file entry> items that is returned is limited to eight.

### **MMEMory:MPResent? <boolean>**

This command is short for *Media Present*. It returns a boolean indicating whether a floppy disk is present.

**System Command Reference Section**  
**User Pattern Disk Operations**

**MMEMory:CPDisk <NR1>**

The mnemonic CPDisk is short for *Copy Pattern to Disk*. The parameter provides the destination store number, and must be between 5 and 12 inclusive.

**MMEMory:ICPDisk <NR1>,AHALf|BHALf,<NR1>,<NR1>**

The mnemonic ICPDisk is short for Incremental Copy Pattern to Disk. It is used to copy just a portion of the current edit buffer to disk. If used on alternate patterns then the pattern half needs to be specified. The four parameters are:

- Parameter No. 1:      The destination store number, between 5 and 12.
- Parameter No. 2:      The pattern half;  
                            For a straight pattern= 0  
                            For an alternate pattern half A or half B.
- Parameter No. 3:      The first bit of the block to copy to disk.
- Parameter No. 4:      The last bit of the block to copy to disk.



## Pattern Generator DATA OUT

In this section the SOURCE1:VOLT and OUTPUT1 commands control the electrical levels at the DATA OUT port. Refer to the next section on page 5-17 for SOURCE10:VOLT and OUTPUT10 commands which provide the corresponding controls, where independently available, for the DATA OUT port.

---

**NOTE** See *Handling Coupled Parameters*, page 2-11.

---

### **[SOURCE[1]:]VOLTage[:LEVel][:IMMediate][:AMPLitude] <numeric value>**

Sets the peak to peak value of the data signal, in units of Volts.

The \*RST selection is 500 mV.

### **[SOURCE[1]:]VOLTage[:LEVel][:IMMediate]:HIGH <numeric value>**

This is used to set the dc high output level, in units of Volts.

The \*RST selection is 0 V.

### **[SOURCE[1]:]VOLTage:ATTenuation <numeric value>**

Specifies, in decibels, the value of external attenuation on the output. This causes the entered/displayed values to be modified so as to reflect the value of the output on the far side of the attenuator.

The \*RST selection is 0 dB.

### **[SOURCE[1]:]VOLTage:ECL**

Sets the output AMPLitude and HIGH values to those used for the ECL family. There is no query form of this command.

### **OUTPUT1[:STATe] <boolean>**

This node controls the data output. When OFF, the output is set to 0 V.

The \*RST selection is ON.

**OUTPut1:COUPling AC|DC**

Sets the data output coupling to ac or dc.

The **\*RST** selection is 0 V dc.

**OUTPut1:POLarity NORMal|INVerted**

Sets the polarity of the data output.

The **\*RST** selection is NORMal.

**OUTPut1:DELay <numeric value>**

Sets the delay of the active edge of the clock output relative to the data output. The units are seconds. The value is rounded to the nearest one picosecond.

The **\*RST** selection is 0 ps.

**OUTPut1:TERMination <numeric value>**

Enables the data termination level to be selected as 0 Volts or –2 Volts.

The **\*RST** selection is 0 V.

## Pattern Generator DATA OUT (inverted)

In this section the SOURCE10:VOLT and OUTPUT10 commands control the electrical levels at the  $\overline{\text{DATA OUT}}$  port. Refer to the previous section on page 5-15 for SOURCE1:VOLT and OUTPUT1 commands which provide the controls for the DATA OUT port.

**NOTE** See *Handling Coupled Parameters*, page 2-11.

### **SOURCE10:VOLTage[:LEVEL][:IMMEDIATE][AMPLITUDE] <numeric value>**

Sets the peak to peak value of the data signal, in units of Volts.

This command is allowed only when tracking is disabled.

The \*RST selection is 500 mV.

### **SOURCE10:VOLTage[:LEVEL][:IMMEDIATE]:HIGH <numeric value>**

This is used to set the dc high output level, in units of Volts.

This command is allowed only when tracking is disabled.

The \*RST selection is 0 V.

### **SOURCE10:VOLTage:TRACK <boolean>**

Enables the Data,  $\overline{\text{Data}}$  Outputs to operate independently or track together.

The \*RST selection is ON.

### **OUTPUT10[:STATE] <boolean>**

This node controls the data output. When OFF, the output is set to 0 V.

The \*RST selection is ON.

## Pattern Generator CLOCK OUT

In this section the SOURCE2:VOLT and OUTPUT2 commands control the electrical levels at the CLOCK OUT port. Refer to the next section on page 5-19 for SOURCE11:VOLT commands which provide the corresponding controls, where independently available, for the CLOCK OUT port.

---

**NOTE** See *Handling Coupled Parameters*, page 2-11.

---

### **SOURce2:FREQUency[:CWI:FIXed]? <numeric value>**

Queries the bit rate of the measured clock frequency at the input of the Pattern Generator. Superseded by SENSE6:FREQUency [:CWI:FIXed]? Retained only for backwards compatibility with HP 71600B systems.

### **SOURce2:VOLTage [:LEVel][:IMMediate][:AMPLitude] <numeric value>**

Sets the peak to peak value of the clock signal, in units of Volts.

The \*RST selection is 500 mV.

### **SOURce2:VOLTage[LEVel][:IMMediate]:HIGH <numeric value>**

This is used to set the dc high output level, in units of Volts.

The \*RST selection is 250 mV.

### **SOURce2:VOLTage:ATTenuation <numeric value>**

Specifies, in decibels, the value of external attenuation on the output. This causes the entered/displayed values to be modified so as to reflect the value of the output on the far side of the attenuator.

The \*RST selection is 0 dB.

### **SOURce2VOLTage:ECL**

Sets the output “AMPLitude” and “HIGH” values to those used for the ECL family. There is no query form for this command.

### **OUTPut2:TERMination <numeric value>**

Enables the clock termination level to be selected as 0 Volts or –2 Volts.

See *Handling Coupled Parameters*, page 2-11.

The \*RST selection is 0 V.

### **OUTPut2:COUPling AC|DC**

Permits the clock output coupling to be set to ac or dc.

The \*RST selection is dc 0 V.

---

## **Pattern Generator CLOCK OUT (inverted)**

In this section the SOURCE11:VOLT commands control the electrical levels at the CLOCK OUT port. Refer to the previous section on page 5-18 for SOURCE11:VOLT and OUTPUT11 commands which provide the controls for the CLOCK OUT port.

---

**NOTE** See *Handling Coupled Parameters*, page 2-11.

### **SOURce11:VOLTage[:LEVel][:IMMediate][:AMPLitude] <numeric value>**

Sets the peak to peak value of the clock output, in units of Volts.

This command is allowed only when tracking is disabled.

The \*RST selection is 500 mV.

### **SOURce11:VOLTage[:LEVel][:IMMediate]:HIGH <numeric value>**

This is used to set the dc high output level, in units of Volts.

This command is allowed only when tracking is disabled.

The \*RST selection is 0 V.

### **SOURce11:VOLTage:TRACK <boolean>**

Enables the Clock, Clock Outputs to operate independently or track together.

The \*RST selection is ON.

## Pattern Generator PARALLEL DATA OUTPUTS

In this section the SOURCE4:VOLT and OUTPUT4 commands control the electrical levels at the subrate PARALLEL DATA OUTPUT ports. Refer to the next section on page 5-21 for SOURCE5:VOLT and OUTPUT5 commands which provide the controls for the SUBRATE CLOCK OUT port.

---

**NOTE** See *Handling Coupled Parameters*, page 2-11.

---

### **SOURce4:VOLTage[:LEVel][:IMMediate][:AMPLitude] <numeric value>**

Sets the peak to peak value of the of the subrate data signal, in units of volts.

The \*RST selection is 500 mV.

### **SOURce4:VOLTage[:LEVel] [:IMMediate]:HIGH <numeric value>**

This is used to set the dc high output level, in units of volts.

The \*RST selection is 0 V.

### **SOURce4:VOLTage:ECL**

Sets the output AMPLitude and HIGH values to those used for the ECL family. There is no query form for this command.

### **OUTPut4:TERMination <numeric value>**

Permits the subrate data output termination to be set to 0 Volts or -2 Volts.

The \*RST selection is 0 V.

### **OUTPut4:COUPling AC|DC**

Permits the subrate data output coupling to be set to ac or dc.

The \*RST selection is 0 V dc.

## Pattern Generator SUBRATE CLOCK OUT

In this section the SOURCE5:VOLT and OUTPUT5 commands control the electrical levels at the SUBRATE CLOCK OUT port. Refer to the previous section on page 5-20 for SOURCE4:VOLT and OUTPUT4 commands which control the subrate PARALLEL DATA OUTPUT ports.

---

**NOTE** See *Handling Coupled Parameters*, page 2-11.

---

### **SOURce5:VOLTage[:LEVel][:IMMediate][:AMPLitude] <numeric value>**

Sets the peak to peak value of the subrate clock, in units of volts.

The **\*RST** selection is 500 mV.

### **SOURce5:VOLTage[:LEVel][:IMMediate]:HIGH <numeric value>**

This is used to set the dc high output level, in units of volts.

The **\*RST** selection is 0 V.

### **SOURce5:VOLTage:ECL**

Sets the output AMPLitude and HIGH values to those used for the ECL family. There is no query form for this command.

### **OUTPut5:TERMination <numeric value>**

Permits the subrate clock output termination level to be set to 0 V or -2 V.

The **\*RST** selection is 0 V.

### **OUTPut5:COUPling AC|DC**

Sets the subrate clock coupling to ac or dc.

The **\*RST** selection is dc 0 V.

## Pattern Generator TRIGGER OUTPUT

The SOURCE3:TRIGger commands control the attributes of the pattern generator's TRIGGER OUTPUT port.

### SOURCE3:TRIGger[:MODE] PATtern|DCLock

This node is for specifying the mode of the trigger output. The possible modes are:

- Pattern**            *The trigger pulse is output coincident with the occurrence, in the data output stream, of a particular pattern of bits.*
- Divided Clock** *The trigger pulse is simply the input data clock divided by a fixed value.*

The \*RST selection is PATtern.

### SOURCE3:TRIGger:DCLRatio <NR1>

This is a contraction of the phrase divided clock division ratio. It permits the ratio between frequency of the clock and the frequency of repetition of the trigger to be set up. Values of 8 and 32 are permitted.

The \*RST selection is 8.

### SOURCE3:TRIGger:CTDRatio? <NR3>

The command is short for Clock to Trigger Division ratio. It gives the ratio between the frequency of the clock output and the frequency of the pulses on the trigger output for the currently selected pattern.

If alternate patterns are selected and the trigger is set to occur on input, then no division ratio is available and this command responds with Not-A-Number (NAN, 9.91 x E+37).

### SOURCE3:TRIGger:PRBS<n> <NRf>{,<NRf>}

This command sets the pattern, the occurrence of which causes a trigger pulse to be output. The number n must one of 7, 10, 15, 23 or 31. The number of parameters depends on the pattern length, and is the minimum that can define a unique place in the overall pattern, for example a pattern of length  $2^n - 1$  the number of parameters is n. The parameter values are either 1 or 0. An *all-ones* pattern is disallowed.

The \*RST selection is ALL ZEROS for n = 1 through 4.



### **SOURce3:TRIGger:ZSUB<n> <numeric value>**

This command selects the position within the PRBS at which the trigger pulse is to be output whenever a Zero Substitution PRBS is selected. The number 'n' must be one of 7, 10, 11 and 13. The parameter must be in the range 0 through (pattern length – 1).

The **\*RST** selection is 0 for n = 7, 10, 11 and 13.

### **SOURce3:TRIGger:MDEN<n> <numeric value>**

This command selects the position within the PRBS at which the trigger pulse is to be output whenever a Mark Density PRBS is selected. The number 'n' must be one of 7, 10, 11 and 13. The parameter must be in the range 0 through (pattern length – 1).

The **\*RST** selection is 0 for n = 7,10,11 and 13.

### **SOURce3:TRIGger:UPAT<n> <numeric value>**

This command selects the position within the PRBS at which the trigger pulse is to be output whenever a Zero Substitution PRBS is selected. The number 'n' must be in the range 0 through 12. The parameter must be in the range 0 through (pattern length – 1).

The commands under this node affect the storage of information as defined in the following table:

<n> = 0	Current pattern
<n> = 1 thru 4	Non-volatile RAM storage
<n> = 5 thru 12	Disk storage

The **\*RST** selection is 0 for n = 0 through 4.

### **SOURce3:TRIGger:APATtern<n> ABCHange|SOPattern**

This command control the trigger output when an alternate pattern is selected for output. If SOPattern (short for Start Of Pattern) is selected, then a trigger pulse is output at the start of the pattern. If ABCHange (short for A-B CHange) is selected, then the trigger output changes as the alternate halves change.

The commands under this node affect the storage of information as defined in the table below:

<n> = 0	Current pattern
<n> = 1 thru 4	Non-volatile RAM storage
<n> = 5 thru 12	Disk storage

The **\*RST** selection is ABCHange.

## Pattern Generator CLOCK IN

The SENSE6 query commands indicate the status of the pattern generator's CLOCK IN port.

### **SENSe6:FREQuency [:CW|:FIXed]?**

Returns the frequency of the clock signal at the pattern generator clock input port.

### **SENSe6:BANDswitch?**

The response to “SENSe6:BANDswitch?” is an integer in the range 0...3 indicating the frequency band configured by the pattern generator.

The response should be interpreted within the controller to mean:

- |   |   |
|---|---|
| 0 | a through (non-band limited) clock path is configured due to the measured input frequency being out of range or unstable. In this configuration no user adjustment of the clock to data delay is available. |
| 1 | the configured clock path has a 0.1 GHz to 3.1 GHz pass band.   |
| 2 | the configured clock path has a 2.9 GHz to 6.1 GHz pass band.   |
| 3 | the configured clock path has a 5.9 GHz to 13.1 GHz pass band.  |

Whenever the HP 71612 is to be used at a number of frequencies, the functions embodied in the BASIC language example given in *Clock Stabilization* on page 9-2 should be employed.

## Slaved MMS Clock Source

The **SOURce9** commands control the setup of the frequency and electrical characteristics of the signal at the clock output port of a slaved MMS Signal Generator.

### **SOURce9:IDN? <string>**

Returns an identification string for the slaved MMS Signal Generator.

### **SOURce9:FREQuency**

**SOURce9:FREQuency [:CW|FIXed] <numeric value>**

Any of the three forms defined by the command syntax above may be used to configure the signal generator frequency.

### **SOURce9:FREQuency:STEP <numeric value>**

**SOURce9:FREQuency [:CW|FIXed] :STEP [:INCRement] <numeric value>**

Any of the six forms defined by the command syntax above may be used to configure the signal generator frequency step size.

### **SOURce9:POWer [:LEVel][:IMMediate][:AMPLitude] <numeric value>**

This node permits the power output levels of the signal generator frequency to be selected.

### **SOURce9:OUTPut <boolean>**

This node switches the signal generator output off or on.

## Error Detector DATA IN

The SENSE1:PATT:VOLT, SENSE1:EYE and INPUT1 commands control the configuration of or indicate the status of the error detector's DATA IN port. The SENSE1:EYE commands control the automatic data/clock delay and automatic zero-one-threshold setting.

### SENSe[1]:VOLTage:ZOTHreshold <numeric value>

This node allows the level at which the error detector discriminates between a zero and a one to be configured.

A numeric value parameter sets the level to a given value. It also sets  
**:ZOTHreshold:AUTO OFF.**

When in **:ZOTHreshold:AUTO OFF**, the query form of the **:ZOTHreshold** command returns the last user-entered value. When in **:ZOTHreshold:AUTO ON**, the query form returns the value automatically determined by the hardware.

If input termination and zero-to-one level are to be set up, then the input termination should be set up first.

The **\*RST** selection is  $-1.3$  V.

### SENSe[1]:VOLTage:ZOTHreshold:AUTO <boolean>

This command enables an automatic mode in which the zero-to-one threshold level is set to the mean of the input signal.

The query form of this command returns the current setting of the hardware discrimination circuit.

The **\*RST** selection is ON.

### SENSe[1]:EYE:TCENter ONCE|<boolean>

**:TCENter ONCE**  
**:TCENtre ONCE**  
**:TCENter ON**  
**:TCENtre ON**

Any of the above commands initiates a search for the value of data/clock delay that puts the active clock edge in the center of the data eye, midway between the two relative delay points with a measured BER just in excess of the BER configured by the **EYE:THreshold** command. If successful, the command leaves the data/clock delay at

**System Command Reference Section**  
**Error Detector DATA IN**

this value and the center of the eye can be found by querying the data delay value. If unsuccessful, the **EYE:WIDTH?** will return NAN (Not-A-Number). The command **:TCENTER | :TCENTRE OFF** aborts a previously started search.

---

**NOTE**

The clock/data align feature (used to center the sampling point in the data input eye) uses information derived from the input clock frequency.

For the clock/data align feature to work properly the input frequency must be stable during the measurement. The frequencies at the start and end of the measurement are compared and if they differ by more than 10% the measurement fails.

When a source clocking the instrument changes frequency it will take time for the instrument to sense the change and adjust its configuration. Refer to the section on page 9-2 dealing with clock stabilization to ensure that the instrument's configuration has stabilized following any change of frequency prior to performing a clock to data alignment.

There is no need to alter the sync-mode before or after a clock to data alignment procedure as AUTO sync-mode is automatically configured for the duration of the procedure.

---

The command **:TCENTER | :TCENTRE** is an overlapped command.

**SENSe[1]:EYE:ACENTER ONCE|<boolean>**

**:ACENTER ONCE**  
**:ACENTRE ONCE**  
**:ACENTER ON**  
**:ACENTRE ON**

Any of the above commands initiates a search for the zero-to-one threshold voltage midway between the two zero-to-one threshold voltages with a measured BER just in excess of the BER configured by the **EYE: THRESHOLD** command. If successful, the command leaves the zero-one-threshold at this value and the center of the eye can be found by querying the zero-one-threshold value. If unsuccessful, the **EYE:HEIGHT?** will return NAN (Not-A-Number).

The command **:ACENTER | :ACENTRE OFF** aborts a previously started search.

The command **:ACENTER | :ACENTRE** is an overlapped command.

**SENSe[1]:EYE:WIDTH? <NR3>**

This command interrogates the eye width found by the most recent search for the value of data/clock delay that put the active edge in the center of the data eye.

If the result is not available or the search was unsuccessful, then the number 9.91 x E+37 (Not-A-Number, NAN) will be returned.

**SENSe[1]:EYE:HEIGht? <NR3>**

This command interrogates the eye height found by the most recent search for the value of data amplitude that puts the zero-to-one threshold level midway between the upper and lower bounds at which the error ratio exceeds the threshold value set up by the :EYE:THReshold command.

If the result is not available or the search was unsuccessful, then the number  $9.91 \times E+37$  (Not-A-Number, NAN) will be returned.

**SENSe[1]:EYE:THReshold <numeric value>**

This command sets the threshold to be used in the determination of the edges of the eye.

**INPut1:POLarity NORMal|INVerted**

Sets the polarity of the detected data signal.

The \*RST selection is NORMal.

**INPut1:DELay <numeric value>**

Sets the delay of the sampling of the data input relative to the active clock edge. The units are in seconds. The value is rounded to the nearest one picosecond.

The \*RST selection is 0 ps.

**INPut1:TERMination <numeric value>**

This node permits the input termination level to be set to 0 Volts (ground) or -2 Volts.

If input termination and zero-to-one threshold level are to be set up, then the input termination should be set up first.

The \*RST selection is 0 V.

## Error Detector CLOCK IN

The SENSE2 and INPUT2 commands control the configuration of or indicate the status of the error detector's CLOCK IN port.

### SENSe2:FREQuency?

```
SENSe2 FREQ?  
SENSe2:FREQ:CW?  
SENSe2:FREQ:FIXed?
```

Any of the above query command forms returns the frequency of the signal at the error detector clock input.

### SENSe2:BANDswitch?

The response to "SENSe2:BANDswitch?" is an integer in the range 0...3 indicating the frequency band configured by the error detector.

The response should be interpreted within the controller to mean:

- 0            a through (non-band limited) clock path is configured due to the measured input frequency being out of range or unstable. In this configuration no user adjustment of the clock to data delay is available.
- 1            the configured clock path has a 0.1 GHz to 3.1 GHz pass band.
- 2            the configured clock path has a 2.9 GHz to 6.1 GHz pass band.
- 3            the configured clock path has a 5.9 GHz to 13.1 GHz pass band.

Whenever the HP 71612 is to be used at a number of frequencies, the functions embodied in the BASIC language example given in *Clock Stabilization* on page 9-2 should be employed.

### INPut2:TERMination <numeric value>

This node permits the input termination level to be set to 0 Volts (ground) or -2 Volts.

```
INPut2  
  :TERMination        <numeric value>  
  TERMination?       <NR1>
```

If input termination and zero-to-one threshold level are to be set up, then the input termination should be set up first.

The \*RST selection is 0 V.

## Error Detector TRIGGER OUTPUT

### **SOURce7:TRIGger[:MODE] PATtern|DCLock**

The command configures the TRIGGER OUTPUT port from the error detector to be either clock mode - a square wave at clock rate/8 or pattern mode - a pulse synchronized to repetitions of the pattern.

The \*RST selection is PAT (pattern).

---

## Error Detector ERRORS OUTPUT

### **OUTPut8:PLENgtH RZ|STRetched**

This node configures the length of the pulse from the error detector ERRORS OUTPUT port. The pulse length can be RZ or stretched 200 ns.

The \*RST selection is RZ.



## Error Detector Pattern Synchronization

### **SENSe[1]:SYNchronisat ONCE|<boolean>**

These commands configure the settings that control synchronization of the reference pattern to the incoming pattern.

SENSe[1]:SYN Chronisat ON           turns automatic resynchronization on.

SENSe[1]:SYNChronisat OFF       turns automatic resynchronization off.

SENSe[1]:SYNChronisat ONCE      initiates a resynchronization attempt.

The **\*RST** selection is ON.

### **SENSe[1]:SYNChronisat:THReshold <numeric value>**

This sets the threshold level of error ratio at which synchronization is deemed to be lost.

---

**NOTE**                   The valid values are 1E-01 through 1E-08 in decade steps.

The **\*RST** selection is 1E-1.

## Error Detector Measurement Gating

The SENSE[1]:GATE commands control the configured parameters and run/stop gating state of the error detector's measurement subsystem. Interpretation of the results obtained using the query commands in *Error Detector Measurement Functions* on page 5-36 should take account of the gating parameters configured by means of the commands given below.

### SENSE[1]:GATE ON

Turns gating on or off.

---

**NOTE**

Previous commands that have altered the configuration of the instrument might still not have settled. In order to ensure that the GATE ON command is not executed until conditions have settled, it is strongly recommended that the frequency has stabilized prior to the GATE ON command, followed by a synchronization search. See *Clock Stabilization* on page 9-2, and *Overview of Control Sequence between Configuration Changes and the Commencement of Bit Error Measurements* on page 2-9.

---

The **GATE[ : STATE] ON** command when in GATE:MODE SINGLE is an overlapped command.

The **\*RST** selection is OFF.

### SENSE[1]:GATE:BURSt <boolean>

Turns Burst Gating on or off.

The **\*RST** selection is OFF.

### SENSE[1]:GATE:MODE MANual|SINGle|REPetitive

Sets the gating period mode to either Manual, Single, or Repetitive.

This command causes all past results to be labelled as invalid.

The **\*RST** selection is MANual.

## **SENSe[1]:GATE:MANNer TIME|ERRors|BITS**

This node controls the manner by which the gating period is controlled.

When TIME is selected the error detector performs SINGLE and REPETITIVE gating periods that are controlled by elapsed time. When the selected time has accumulated, the gating period ends.

When ERRors is selected the error detector performs SINGLE and REPETITIVE gating periods that are controlled by the accumulation of bit errors. When the selected number of bit errors have been accumulated, the gating period ends.

When BITS is selected the error detector performs SINGLE and REPETITIVE gating periods that are controlled by the accumulation of clock bits. When the selected number of clock periods have been accumulated, the gating period ends.

The \*RST selection is TIME.

## **SENSe[1]:GATE:PERiod**

This node controls the period of SINGLE and REPETITIVE gating periods.

### **SENSe[1]:GATE:PERiod[:TIME] <numeric value>**

When GATE:MANNer is set to TIME, this sets the duration of the gating period in seconds. Neither a value less than 1 second nor a value greater than 99 days, 23 hours, 59 minutes and 59 seconds is permitted.

This command causes all past results to be labelled as invalid.

The \*RST selection is 1 minute.

### **SENSe[1]:GATE:PERiod:ERRors <numeric value>**

When GATE:MANNer is set to TIME, this sets the duration of the gating period in bit errors. Values of 10, 100 and 1000 are permitted.

This command causes all past results to be labelled as invalid.

The \*RST selection is 100.

### **SENSe[1]:GATE:PERiod:BITS <numeric value>**

When GATE:MANNer is set to TIME, this sets the duration of the gating period in clock bits (or periods). Values of 1E7 through 1E15 in decade steps are permitted.

This command causes all past results to be labelled as invalid.

The \*RST selection is 1E10.

## Error Detector Error Location

The *Error Location* features of the error detector have three forms, all of which may be used when the instrument has any RAM-based pattern configured, i.e. the functions are not available when any one of the five pure PRBS patterns is selected. The three forms are: Bit BER, Error Location capture and Block BER.

*Whole Pattern BER*, *Bit BER* and *Block BER* are mutually exclusive operating modes of the error detector. When in Block BER mode the bit error and clock counting functions underlying the query commands in *Error Detector Measurement Functions* on page 5-36 are altered in accordance with the block start and length parameters. Pattern synchronization is also affected.

In general Block BER is not measured on every repetition of the pattern. The number of times a pattern will be repeated when configuring the pattern generator and detector depends on the pattern length and is defined by table 4-2 of the Operating Manual. Where it is important to make Block BER measurements on every repetition of the pattern the pattern length must be set to a multiple of 256 bits.

### SENSe[1]:ELOCation ONCE

This initiates an error location capture measurement. This is an overlapped command.

### SENSe[1]:ELOCation?

The boolean response to this query command is *true* during an error location capture, and *false* at all other times.

### SENSe[1]:ELOCation:BEAddress <numeric value>

This command configures the single bit BER “BIT: Error address”

The query form of this command will only return the last configured value of the bit error address provided no bit error has occurred (while a RAM pattern was selected) since the last error location capture operation was started, for example, using the “SENSe1:ELOC ONCE” command. Where a bit error has been *captured* the query command returns the bit error address of the errored bit. This address is automatically configured as the bit error address for the single Bit BER measurements. Thus when the gated single Bit BER measurements are of interest, one would expect to re-start gating after any error location capture had *fired*.

**System Command Reference Section**  
**Error Detector Error Location**

**SENSe[1]:BLOCK <boolean>**

This command turns Block BER mode on or off.

**SENSe[1]:BLOCK:BSTart <numeric value>**

This command sets the start address of the block. Where the start bit number is configured to be less than 32 bits from the end of the pattern the block BER function automatically wraps around to include the appropriate number of bits at the start of the pattern.

**SENSe[1]:BLOCK:BLENgtH <numeric value>**

This command sets the length of the block. It must be a multiple of 32.

## Error Detector Measurement Functions

The **FETCh** | **PFETCh** command is used to return measurement values from the error detector. The **FETCh** command returns the results for the current gating period, and the **PFETCh** (Previous **FETCh**) returns the results for the previous gating period. The **PFETCh** command is valid only in Repetitive Timed gating periods.

If any result is not available, then the number 9.91 x E+37 (Not-A-Number, NAN) will be returned.

Interpretation of the results obtained using query commands of gated results in this section should take account of the gating parameters configured by means of the commands given in *Error Detector Measurement Gating* on page 5-32.

The **FETCh[:SENSE[1]]** query commands apply to measurements on the data input. The **FETCh:SENSE2** query commands apply to measurements on the clock input.

### **FETCh[:SENSE[1]]:ECOut**

This is a contraction of the phrase Error COUnT and returns the number of errors counted in a time specified by the next level in the command. The next level is:

- [[:ALL]][:FULL][:TOTa]? <NR3>** The total number of errors accumulated since the start of the gating period.
- [[:ALL]][:FULL]:DELTA? <NR3>** The number of errors in the last decisecond. This is intended to give a result that corresponds to the “instantaneous” error count. This value is available even when gating is turned off.
- :ZASone[:TOTa]? <NR3>** This is a contraction of the phrase *Zero received AS One*. The command returns the number of errors accumulated since the start of the gating period, where each error is a true data zero received as a data one.
- [[:ALL]] BIT [:TOTa]? <NR3>** The total number of errors accumulated on the currently selected bit since the start of the gating period.
- [[:ALL]] BIT:DELTA? <NR3>** The number of errors accumulated in the last decisecond on the currently configured “BIT Error address”.
- :OASZero[:TOTa]? <NR3>** This is a contraction of the phrase *One received AS Zero*. The command returns the number of errors accumulated since the start of the gating period, where each error is a true data one received as a data zero.

## FETCH[:SENSe[1]]:ERATio

This is a contraction of the phrase “Error RATio” and is the ratio of the number of errors to the number of bits received in a time interval, specified by the next level in the command. The next level is:

- [ :ALL ] [ :FULL ] [ :TOTal ] ? <NR3> The error ratio calculated from the total clock and bit error counts accumulated since the start of the gating period.
- [ :ALL ] [ :FULL ] :DELTA ? <NR3> The “instantaneous” error ratio calculated from the counts obtained in the last decisecond. This value is available even when gating is turned off.
- [ :ALL ] BIT [ :TOTal ] ? <NR3> The error ratio calculated on the currently configured “BIT: Error address” since the start of the gating period.
- [ :ALL ] BIT :DELTA ? <NR3> The error ratio over the last decisecond on the currently selected bit.
- :ZASone [ :TOTal ] ? <NR3> This is a contraction of the phrase *Zero received AS One*. The command returns the error ratio calculated from a count of errors, where each error is a true data zero received as a data one.
- :OASZero [ :TOTal ] ? <NR3> This is a contraction of the phrase *One received AS Zero*. The command returns error ratio calculated from a count of errors, where each error is a true data one received as a data zero.

## FETCH[:SENSe[1]]:EINTerval

This is a contraction of the phrase Errored INTerval and returns a count of the number of time intervals, the duration of which is selected by the next node, in which one or more errors were detected. The four time interval classifications are:

- |                  |                        |
|------------------|------------------------|
| :SEConds? <NR3>  | <i>One second</i>      |
| :DSEConds? <NR3> | <i>One decisecond</i>  |
| :CSEConds? <NR3> | <i>One centisecond</i> |
| :MSEConds? <NR3> | <i>One millisecond</i> |

### **FETCH[:SENSe[1]]:EFINterval**

This is a contraction of Error Free INterval and returns a count of the number of time intervals, the duration of which is selected by the next node, in which no error was detected. The four time interval classifications are:

<b>:SEConds?</b> <NR3>	<i>One second</i>
<b>:DSEConds?</b> <NR3>	<i>One decisecond</i>
<b>:CSEConds?</b> <NR3>	<i>One centisecond</i>
<b>:MSEConds?</b> <NR3>	<i>One millisecond</i>

### **FETCH[:SENSe[1]]:LOSS:POWer? <NR3>**

This is the count of the number of seconds for which power was lost, since the start of the gating period.

If the Error Detector is not connected to an HP 70004A Display, then this measurement is not available. If received, then it will return 9.91 x E+37 (Not-A-Number, NAN).

### **FETCH[:SENSe[1]]:LOSS:SYNChronisat? <NR3>**

This is the count of the number of seconds for which the incoming pattern was not synchronized to the reference pattern, during the gating period.

### **FETCH[:SENSe[1]]:G821**

This node returns a percentage of seconds that have been classified according to the CCITT's G.821 specification. The subordinate nodes, representing the classifications, are:

<b>:AVAIlability?</b> <NR3>	<i>% Availability</i>
<b>:UNAVAIlabili?</b> <NR3>	<i>% Unavailability</i>
<b>:SESeconds?</b> <NR3>	<i>% Severely Errored Seconds</i>
<b>:DMINutes?</b> <NR3>	<i>% Degraded MINutes</i>
<b>:ESEConds?</b> <NR3>	<i>% Errored SEConds</i>

### **FETCH[:SENSe[1]]:GATE**

This node is used to return information about the gating period.



**System Command Reference Section**  
**Error Detector Measurement Functions**

**FETCH[:SENSe[1]]:GATE:ELAPsed? <NR3>**

This node returns information about the degree to which the gating period has progressed. If GATE:MANNer TIME is selected, then this command returns the elapsed time into the gating period in units of seconds. If GATE:MANNer ERRors is selected, then this command returns the elapsed errors into the gating period. IF GATE:MANNer BITS is selected, then this command returns the elapsed clock bits into the gating period.

**FETCH[:SENSe[1]]:LTEXT?**

This query command returns one line of log output. If a line of text is not currently available, then the message *No text currently available* is returned.

Refer to *Error Detector Result and Configuration Logging*, page 5-45, for information on the configuration of the logging functions using this query command while the instrument is under remote control.

**FETCH:SENSe2:FREQuency? <NR3>**

This returns the current frequency of the signal on the clock input. This measurement is independent of the gating period.

Superseded by SENSe2:FREQuency[:CW]:FIXEd)?

Retained for backwards compatibility with HP 71600B systems.

**FETCH:SENSe2:BCOunt?**

Returns the accumulated bit count since the start of gating.

## Result and Configuration Window Selection and Composition

The DISPLAY subsystem defines the usage of the display.

The available commands are:

### DISPlay: WINDOW

This node defines the usage of the display.

### DISPlay:WINDow[:RESults] <parameter>

This command selects the (blue) results window to be viewed. The <parameter> string values are:

<b>MAIN</b>	<i>Main Results page</i>
<b>OTHer</b>	<i>Other Results page</i>
<b>INTerval</b>	<i>Interval Results page</i>
<b>G821</b>	<i>G.821 Results page</i>
<b>EYE</b>	<i>Eye Results page</i>
<b>USER</b>	<i>USER'S page</i>

The \*RST selection is MAIN.

### DISPlay:WINDow:CONFig <parameter>

This command selects the (green) configuration window to be viewed. The <parameter> string values are:

<b>PATTErn</b>	<i>shows current pattern configuration</i>
<b>DOUtpuT</b>	<i>shows current data output configuration</i>
<b>COUtpuT</b>	<i>shows current clock output configuration</i>
<b>EADD</b>	<i>shows current error add configuration</i>
<b>SOUtpuT</b>	<i>shows current subrate outputs configuration</i>
<b>TSETup</b>	<i>shows current trigger &amp; setup configuration</i>
<b>MISC</b>	<i>shows current miscellaneous configuration</i>
<b>IEYE</b>	<i>shows current input &amp; eye configuration</i>
<b>SAUDio</b>	<i>shows current sync &amp; audio configuration</i>
<b>GATing</b>	<i>shows current gating configuration</i>
<b>ELOCation</b>	<i>shows current error location configuration</i>
<b>LOGGing</b>	<i>shows current logging configuration</i>

The \*RST selection is PATTErn.

## DISPlay:REPort PREVIOUS|CURRENT

This subsystem configures the result displays to show answers relating to either the previous gating period or current gating period. It has no effect on the results returned following the FETCh or PFETCh commands.

The \*RST selection is PREV.

## DISPlay:UPAGe[:DEFine] <parameter>

This subsystem configures the user-defined page to hold particular results or status information. As each command is received, the chosen parameter is added to the next vacant location in the User's Page, or removed if it is already there. The single parameter is chosen from the following:

PGCFrequency *pat gen i/p clock freq*  
EDCFrequency *err det i/p clock freq*

BCOunt *bit count*  
ECOunt *error count*  
ERATio *error ratio*  
DCOunt *delta error count*  
DRATio *delta error ratio*  
ERRors *errors*

ZECOunt *zero as one error count*  
OECOunt *one as zero error count*  
ZERatio *zero as one error ratio*  
OERatio *one as zero error ratio*

ECBit *bit error count*  
ERBit *bit error ratio*  
DECBit *bit delta error count*  
DERBit *bit delta error ratio*

ERSeconds *error seconds*  
EDSeconds *error deciseconds*  
ECSeconds *error centiseconds*  
EMSeconds *error milliseconds*  
EFSeconds *error free seconds*  
EFDSeconds *error free deciseconds*  
EFCSeconds *error free centiseconds*  
EFMSeconds *error free milliseconds*

PLSeconds *power loss seconds*  
SLSeconds *sync loss seconds*

System Command Reference Section  
Result and Configuration Window Selection and Composition

AVAILability	<i>G.821 availability</i>
UNAVAILabili	<i>G.821 unavailability</i>
SESeconds	<i>G.821 severely errored secs</i>
ERDSeconds	<i>G.821 errored seconds</i>
DMINutes	<i>G.821 degraded minutes</i>
BECount	<i>BIG error count</i>
BERatio	<i>BIG error ratio</i>
BEDCount	<i>BIG delta error count</i>
BEDRatio	<i>BIG delta error ratio</i>
BGELapsed	<i>BIG gating elapsed</i>
EWIDth	<i>eye width</i>
EHEight	<i>eye height</i>
TCENter	<i>eye time center</i>
VCENter	<i>eye voltage center</i>
CTHReshold	<i>eye center threshold</i>
CFRequency	<i>eye center frequency</i>
CDERatio	<i>eye center delta ratio</i>
ESTatus	<i>eye status</i>
EETHreshold	<i>eye edge threshold</i>
PIDentity	<i>pattern identity</i>
PGTMode	<i>pat gen trig mode</i>
PGTRigger	<i>pat gen trigger</i>
COAMplitude	<i>clock o/p amplitude</i>
CBAMplitude	<i>clock bar o/p amplitude</i>
COHLevel	<i>clock o/p hi-level</i>
CBHLevel	<i>clock bar o/p hi-level</i>
COTerm	<i>clock o/p termination</i>
CBTRack	<i>clock bar tracking</i>
DOAMplitude	<i>data o/p amplitude</i>
DBAMplitude	<i>data bar o/p amplitude</i>
DOHLevel	<i>data o/p hi-level</i>
DBHLevel	<i>data bar o/p hi-level</i>
DOTerm	<i>data o/p termination</i>
DOControl	<i>data o/p control</i>
DBControl	<i>data bar o/p control</i>
DOPolarity	<i>data o/p polarity</i>
DODelay	<i>data o/p delay</i>
DBTRack	<i>data bar tracking</i>
SDAMplitude	<i>subrate data o/p amplitude</i>

System Command Reference Section  
Result and Configuration Window Selection and Composition

<b>SDHLevel</b>	<i>subrate data o/p hi-level</i>
<b>SDTerm</b>	<i>subrate data o/p termination</i>
<b>SCAmplitude</b>	<i>subrate clock o/p amplitude</i>
<b>SCHLevel</b>	<i>subrate clock o/p hi-level</i>
<b>SCTerm</b>	<i>subrate clock o/p termination</i>
<b>EADD</b>	<i>error add</i>
<b>EDTMode</b>	<i>err det trig mode</i>
<b>EDEoutput</b>	<i>err det error output</i>
<b>ZOTHreshold</b>	<i>0/1 threshold</i>
<b>DIPolarity</b>	<i>data i/p polarity</i>
<b>DIDelay</b>	<i>data i/p delay</i>
<b>DITerm</b>	<i>data i/p termination</i>
<b>CITerm</b>	<i>clock i/p termination</i>
<b>SMODE</b>	<i>sync mode</i>
<b>STHReshold</b>	<i>sync threshold</i>
<b>GRMode</b>	<i>gating repeat mode</i>
<b>GDMode</b>	<i>gating duration mode</i>
<b>GPERiod</b>	<i>gating period</i>
<b>GREPort</b>	<i>gating report</i>
<b>GELapsed</b>	<i>gating elapsed</i>
<b>BEAddress</b>	<i>bit error address</i>
<b>BSAddress</b>	<i>block start address</i>
<b>BLENgt</b>	<i>block length</i>
<b>LGStatus</b>	<i>logging status</i>
<b>ALOGging</b>	<i>alarms logging</i>
<b>LEReport</b>	<i>log end report</i>
<b>SStatus</b>	<i>sqelch status</i>
<b>LTHReshold</b>	<i>logging threshold</i>
<b>LDTRigger</b>	<i>log during trigger</i>
<b>LETRigger</b>	<i>log end trigger</i>
<b>SGFrequency</b>	<i>sig gen frequency (with slaved sig gen)</i>
<b>SGAmplitude</b>	<i>sig gen amplitude (with slaved sig gen)</i>
<b>SGOutput</b>	<i>sig gen output (with slaved sig gen)</i>

**System Command Reference Section**  
**Result and Configuration Window Selection and Composition**

The default values of the User's Display Page are:

	<b>INSTR PRESET</b>	<b>PRESET 1 &amp; PRESET 2</b>
Line 1:	pattern	B I G error count
Line 2:	bit count	B I G error count
Line 3:	Pat gen clock freq	B I G error count
Line 4:	Err det clock freq	B I G error count
Line 5:	error count	B I G error ratio
Line 6:	error ratio	B I G error ratio
Line 7:	errors	B I G error ratio
Line 8:	0/1 threshold y	B I G error ratio
Line 9:	Sync mode	Errors
Line 10:	Gating repeat mode	Pattern
Line 11:	Gating period	Err det clock freq
Line 12:	gating elapsed	gating elapsed

The query form of the command returns a <boolean> to indicate whether a particular item is currently contained within the User's Page.

**DISPlay:UPAGe:CLEAr**

Clears the contents of the user-defined page.

## Error Detector Result and Configuration Logging

The logging of error detector results and configuration settings to an HP-IB printer at address 1 is mutually exclusive with any remote control of the instrument using the same HP-IB interface.

Although the logging of error detector results and configuration settings may predominantly be of use when the instrument is under local control and configured with the “Log to” setting configured to either “HPIB prnter,addr 1” or “RS232 printer” the logging capabilities may also be used in conjunction with or instead of the query commands defined in *Error Detector Measurement Functions* on page 5-36.

While under remote control via the rear panel HP-IB interface the SENSE1:LOGG:PORT command does, however, permit redirection of the logging information between a printer connected to the RS232 interface and the controlling computer system.

The SENSE1:LOGG commands control when a line of text is generated and made available to be read by the controller. An SRQ is asserted when a line of text is available. Refer to **FETCH[ :SENSE[1]] :LTEXT?** on page 5-39 for a definition of the command which provides remote querying of the logged information.

### SENSE[1]:LOGGing ONCE<boolean>

The **LOGGing ONCE** command is equivalent to the front-panel **logging** key.

The **LOGGing <boolean>** command enables and disables the logging capability.

The **\*RST** selection is OFF.

### SENSE[1]:LOGGing:SQUelch <boolean>

This command controls the logging squelch command. When enabled, further output of logged text is inhibited if triggered for ten consecutive seconds.

The **\*RST** selection is OFF.

### SENSE[1]:LOGGing:ALARms <boolean>

This command controls the output of alarm conditions.

The **\*RST** selection is OFF.

**SENSe[1]:LOGGing:THReshold <numeric parm>**

This command permits a threshold to be set against which logging conditions are compared to decide when some logged information is output.

The **\*RST** selection is 1.00E-3.

**SENSe[1]:LOGGing:DURing[:EVENT] NEVer|ESECond|ERGThrshld**

This command selects which of three conditions apply when deciding when to log output during a gating period. The choices are between 'never', 'on the occurrence of an error second' and 'when the error ratio over a second is greater than the threshold'.

The **\*RST** selection is ESECond.

**SENSe[1]:LOGGing:END[EVENT]NEVer| ALWays|NZECount|  
TERGthrshld**

This command selects which of four conditions apply when deciding when to log output at the end of a gating period. The choices are between 'never', 'always', 'only on non-zero error count' and 'total error ratio greater than the threshold'.

The **\*RST** selection is ALWays.

**SENSe[1]:LOGGing:END:REPort FULL|UREP**

This command selects what to output at the end of a gating period. The choices are between 'FULL' that is, Main Results plus Interval Results plus G.821 Analysis, and 'UREP', that is results currently part of the User's Page.

The **\*RST** selection is FULL.



## System Level Status and Control

The SYSTem subsystem is mostly defined by SCPI for functions that are not related to instrument performance.

### Audio Output on Bit Errors

The SYSTem:BEEPer commands configure the error detector's built-in audio output.

#### **SYSTem:BEEPer[:IMMediate] [<freq> [,<time> [,<vol>]]]**

Causes an audible tone to be generated. The optional parameters <freq>, <time> and <vol> are intended (in SCPI) to set the frequency, duration and volume of the beep.

There is no query form of this command.

#### **SYSTem:BEEPer:STATe <boolean>**

Controls whether the error detector beeps when an error is detected. (In this context "error" means a erroneous data bit on the data input not an internal instrument error nor an HP-IB message error.)

The \*RST selection is OFF.

#### **SYSTem:BEEPer:VOLume <numeric value>**

This command sets the volume of the audible beep that sounds when an error occurs. Values between 1 and 15 are permitted.

The \*RST selection is 1.

#### **SYSTem:ERRor?**

This query-only command will pull the next error from the error queue, and return the error number and a string describing the error. The error queue is of depth ten.

---

**NOTE** SCPI-defined errors are all negative. The positive error numbers are specific to the Error Performance Analyzer. The SCPI Messages section at the rear of this manual contains a list of error numbers.

---

### **SYSTEM:KLOCK <boolean>**

This locks the instrument's keyboard. When locked, the user may not modify any of the instrument's configuration; although those keys that merely affect the display are still usable.

The \*RST selection is OFF.

### **SYSTEM:PRESet|:PRESet<n>**

Sets the error detector to a pre-defined "local operation" state. The choice of <n> is 0 through 2. **PRESet** and **PRESet0** both have the same effect as the front-panel **INST PRESET** key. **PRESet1** and **PRESet2** have the same effect as the front-panel **recall setup Preset 1** and **Preset 2** keys respectively.

This command causes all past results to be labelled as invalid.

---

**NOTE** The HP-IB bus will be held off for approximately 8 seconds following receipt of this command to allow the instrument to settle fully.

---

---

**NOTE** If **PRESet2** is selected whilst an external controller is connected, then an error message is given because the instrument is attempting to take over HP-IB whilst it is already under control of the controller.

---

### **SYSTEM:VERSion?**

This command queries the version of the SCPI programming Language that the pattern generator conforms to. The command currently returns **1990.0**.

### **SYSTEM:DATE <year>,<month>,<day>**

This command permits the date of the real-time clock within the error detector to be set up. The command is invalid if another MMS module, with an HP-MSIB address to the left of and on the same row or lower than the error detector, exists and supports a valid date.

The range of valid <year> is 1990 through 2049.

### **SYSTEM:TIME <hour>,<minute>,<second>**

This command permits the time of the real-time clock within the error detector to be set up. The command is invalid if another MMS module, with an HP-MSIB address to the left of and on the same row or lower than the error detector, exists and supports a valid time.

**SYSTEM:FREVISION[:CProcessor][:APPLICATION]?**

This command permits the revision number of the control processor application firmware to be queried.

**SYSTEM:FREVISION[:CProcessor]BOOT?**

This command permits the revision number of the control processor boot firmware to be queried.

**SYSTEM:FREVISION[:MProcessor][:APPLICATION]?**

This command permits the revision number of the measurement processor application firmware to be queried.

**SYSTEM:FREVISION[:MProcessor]BOOT?**

This command permits the revision number of the measurement processor boot firmware to be queried.

**SYSTEM:FUPDATE CAPPLICATION|MAPPLICATION**

This command permits a new version of either the control processor application or measurement processor application firmware to be loaded into the instrument from floppy disk. The disk containing a suitable revision of firmware must be present in the instrument's disk drive unit.

## Instrument Status

The status conditions that the error detector needs to report are partly covered by the pre-defined status registers of *IEEE 488.2* and *SCPI*.

Refer to chapter 3 *Interrogating the Instrument Status* for a more detailed discussion on the use of query commands described below.

The set commands are used to:

- a. Configure the PTRansition and NTRansition filters in each group in order to determine which transitions to bits within the CONDition register cause an event to be latched into the corresponding bit of the EVENT register for that group,
- b. Configure the ENABle register to determine which events will be propagated into the summary bit in the Status Byte (or, when applicable, from the Clock LOSS EVENT register into the bit 9 of the QUEStionable CONDition register).

The query commands are used to:

- a. Query the currently configured masks within the PTRansition, NTRansition or ENABle registers.
- b. Query the current CONDition register contents.
- c. Query the current EVENT register contents.

### **STATUS:OPERation:[EVENT|CONDition|ENABle|PTRansition|NTRansition]**

The bits in this register permit the operational status of the error detector to be interrogated. All bits are CONDition bits, except for BIT ERROR and END PERIOD which are EVENT bits.

Refer to table 3-6 on page 3-15 for a detailed definition of the bits within the operational status register group.

### **STATUS:QUEStionable:[EVENT|CONDition|ENABle|PTRansition|NTRansition]**

The bits in this register indicate that a signal is of questionable quality.

Refer to table 3-5 on page 3-12 for a detailed definition of the bits within the questionable status register group.

## **STATUS:CLOSs Register:[EVENT|CONDition|ENABle|PTRansition|NTRansition]**

The bits in this register indicate pattern generator and error detector clock loss.

Refer to table 3-3 on page 3-10 for a detailed definition of the bits within the clock loss register group.

## **STATUS:FAILure:EVENT**

The bits in this register indicate that a major hardware element of the instrument has failed. No capability is provided to query the condition register, setup the enable register, nor setup the positive or negative transition filters. This is because failures within this category are non-recoverable, and as such the enable registers are pre-defined.

Refer to table 3-4 on page 3-11 for a detailed definition of the bits within the failure status register group.

## **STATUS:PRESet**

The **PRESet** command is an event that configures the SCPI and device dependent status data structures, such that the device dependent events are reported at a higher level through the mandatory part of the status reporting structures.

The **PRESet** command affects only the enable register and the transition filter registers for the SCPI mandated and device dependent status data structures. **PRESet** does not affect either the “status byte” or the “standard event status” as defined by IEEE 488.2. **PRESet** does not clear any of the event registers. The **\*CLS** command is used to clear all event registers in the device status reporting mechanism.

For the device dependent status data structures, the **PRESet** command sets the enable register to all *one*'s and the transition filter to recognize both positive and negative transitions. For the SCPI mandatory status data structures, the **PRESet** command sets the transition filter registers to recognize only positive transitions and sets the enable register to zero.

## **IEEE Common Commands and Queries**

IEEE 488.2 defines commands that begin with “\*”. Some of these are mandatory in all instruments and others are optional.

### **IEEE Mandatory Commands**

The following IEEE 488.2 mandatory commands are implemented:

*CLS	Clear Status Command.
*ESE	Standard Event Status Enable Command.
*ESE?	Standard Event Status Enable Query.
*ESR?	Standard Event Status Register Query.
*IDN?	Identification Query.
*OPC	Operation Complete Command.
*OPC?	Operation Complete Query.
*RST	Reset Command.
*SRE	Service Request Enable Command.
*SRE?	Service Request Enable Query.
*STB?	Read Status Byte Query.
*TST?	Self-Test Query.
*WAI	Wait-to-Continue Command.

### **IEEE Optional Commands**

The following optional commands are implemented:

*OPT?	Option Identification Query.
*PSC	Power On Status Clear Command.
*PSC?	Power On Status Clear Query.
*RCL	Recall device setup.
*SAV	Save device setup.

### **Response to Identification Common Query \*IDN?**

The response semantics are organized into four fields separated by commas. The field definitions are as follows:

Field 1	Manufacturer	HEWLETT-PACKARD
Field 2	Model	70843A
Field 3	Serial Number	xxxxU00xxx
Field 4	Firmware Level	X nn.nn

**System Command Reference Section**  
**IEEE Common Commands and Queries**

**Effect of Common Command \*RST**

The **\*RST** command sets the device-specific functions to a known state that is independent of the past-use history of the device. The command has the same effect as the front-panel **INST PRESET** key.

In addition, receipt of **\*RST** by the error detector will cause all past results to be labelled invalid.

---

**NOTE** The HP-IB bus will be held off for approximately 8 seconds following receipt of this command to allow the instrument to settle fully.

---

**Scope of the Common Command \*TST?**

The instrument settings are not affected by this command. This command is not accepted by the error detector if it is currently gating.

The scope of this command is to test the processor RAM, ROM, DIL switches, gate array RAM, dual-port RAM, measurement processor and floppy disk drive

**Response to Identification Common Query \*OPT?**

Two comma-separated fields are returned:

**Field one:** UHF - Error Detector and Pattern Generator.  
UHH - Error Detector only.  
UHG - Pattern Generator only.

**Field two** UHJ - Error Location option installed.  
0 - Error Location option not installed.

**Effect of the Common Command \*RCL**

Syntax “\*RCL <NRf>”

This command recalls the setup from a numbered store. The range of store numbers is 0 through 9.

In addition, receipt of **\*RCL** by the Error detector will cause all past results to be labelled invalid.

---

**NOTE** The HP-IB bus will be held off for approximately 8 seconds following receipt of this command to allow the instrument to settle fully.

---





---

**TMSL Command Definition  
Quick Reference Guide**

## Introduction

The following pages list the TMSL commands for the HP 71612 Option UHF Error Performance Analyzer.

**Table 6-1** Definition of Input/Output Ports

Port	Pattern Generator		Error Detector		MMS slaved Signal Generator
1	Data output port:	SOURce1	Data input port:	SENSe1	
		OUTPut1		INPut1	
2	Clock output port:	SOURce2	Clock input port:	SENSe2	
		OUTPut2		INPut2	
3	Trigger output port:	SOURce3			
4	Subrate data output port:	SOURce4			
		OUTPut4			
5	Subrate clock output port:	SOURce5			
		OUTPut5			
6	Clock input port:	SENSe6			
7			Trigger output port:	SOURce7	
8			Error output port:	OUTPut8	
9					Clock output port: SOURce9
10	$\overline{\text{Data}}$ output port:	SOURce10			
		OUTPut10			
11	$\overline{\text{Clock}}$ output port:	SOURce11			

# The Pattern Generator

---

## Port 1: the pattern generator data output port

### SOURce1: The Data Source

KEYWORD	PARAMETER FORM	COMMENTS
[SOURce[1]:]		
PATtern		
[:SElect]	PRBS<n>   ZSUBstitut<n>   MDENsity<n>   UPATtern<n>	
[:SElect]?	PRBS<n>   ZSUB<n>1 MDEN<n>   UPAT	
:ZSUBstitut		
[:ZRUN]	<numeric value>	
[:ZRUN]?	<NR1>	
:MDENsity		
[:DENsity]	<numeric value>	
[:DENsity]?	<NR3>	
:UPATtern<n>		
[:LENGth]	<numeric value>	
[:LENGth]?	<NR1>	
:LABel	<string>	
:LABel?	<string>	
:USE	STRAight   APATtern	
:USE?	STR   APAT	
:DATA	[A B,]<block data>	
:DATA?	[A B,]<block data>	
:IDATA	[A B,]<start bit>, <length in bits>,<block data>	
:IDATA?	[A B,]<start bit>, <length in bits>	
:LMOdified?	<string>	
:FORMat		
[:DATA]	PACKed,<numeric value>	
[:DATA]?	PACK,<NR1>	
:APCHange		
:SOURce	EXTernal   INTernal	
:SOURce?	EXT   INT	
:MODE	ALTErnate   ONEShot	
:MODE?	ALT   ONES	

**TMSL Command Definition Quick Reference Guide**  
**Port 1: the pattern generator data output port**

KEYWORD	PARAMETER FORM	COMMENTS
:SElect	AHALf BHALf	only if INT & ALT
:SElect?	AHAL BHAL	only if INT & ALT
:IBHalf	ONCE	only if INT & ONES event; no query
:EADdition	ONCE <boolean>	
:EADdition?	<boolean>	
:SOURce	EXTernal FIXed	
:SOURce?	EXT FIX	
:RATE	<numeric value>	
:RATE?	<NR3>	
<b>VOLTage</b>		
[:LEVel]		
[:IMMediate]		
[:AMPLitude]	<numeric value>	
[:AMPLitude]?	<NR3>	
:HIGH	<numeric value>	
:HIGH?	<NR3>	
:ATTenuation	<numeric value>	
:ATTenuation?	<NR3>	
:ECL	---	event; no query

### **OUTPut1: The Data Output**

KEYWORD	PARAMETER FORM	COMMENTS
OUTPut[1]		
[:STATE]	<boolean>	
[:STATE]?	<boolean>	
:COUpling	AC DC	external coupling
:COUpling?	AC DC	external coupling
:POLarity	NORMal INVerted	
:POLarity?	NORM INV	
:DELay	<numeric value>	
:DELay?	<NR3>	
:TERMination	<numeric value>	
:TERMination?	<NR1>	

---

## Port 2: the pattern generator clock output port

### SOURce2: The Clock Source

KEYWORD	PARAMETER FORM	COMMENTS
SOURce2		
:FREQuency		
[:CWI:FIXed]?	<NR3>	query only
:VOLTage		
[:LEVel]		
[:IMMediate]		
[:AMPLitude]	<numeric value>	
[:AMPLitude]?	<NR3>	
:HIGH	<numeric value>	
:HIGH?	<NR3>	
:ATTenuation	<numeric value>	
:ATTenuation?	<NR3>	
:ECL	---	event; no query

### OUTPut2: The Clock Output

KEYWORD	PARAMETER FORM	COMMENTS
OUTPut2		
:COUPling	AC DC	external coupling
:COUPling?	AC DC	external coupling
:TERMination	<numeric value>	
:TERMination?	<NR1>	

---

## Port 3: the pattern generator trigger output port

### SOURce3: The Trigger Source

KEYWORD	PARAMETER FORM	COMMENTS
SOURce3		
:TRIGger		
[:MODE]	PATtern DCLock	
[:MODE]?	PATT DCL	
:DCDRatio	<numeric value>	
:DCDRatio?	<NR1>	
:CTDRatio?	<NR3>	query only
:PRBS<n>	<NRf>t,<NRf>}	
:PRBS<n>?	<NR1>4,<NR1>}	
:ZSUBstitut<n>	<numeric value>	
:ZSUBstitut<n>?	<NR1>	
:MDENsity<n>	<numeric value>	
:MDENsity<n>?	<NR1>	
:UPATtern<n>	<numeric value>	
:UPATtern<n>?	<NR1>	
:APATtern<n>	ABCHange SOPattern	
:APATtern<n>?	ABCH SOP	

## Port 4: the pattern generator subrate data output port

### SOURce4: The Subrate Data Source

KEYWORD	PARAMETER FORM	COMMENTS
SOURce4		
VOLTage		
[:LEVel]		
[:IMMediate]		
[:AMPLitude]	<numeric value>	
[:AMPLitude]?	<NR3>	
:HIGH	<numeric value>	
:HIGH?	<NR3>	
:ECL	---	Event; no query

### OUTPut4: The Subrate Data Output

KEYWORD	PARAMETER FORM	COMMENTS
OUTPut4		
:COUPling	AC DC	external coupling
:COUPling?	AC DC	external coupling
:TERMination	<numeric value>	
:TERMination?	<NR1>	

## Port 5: the pattern generator subrate clock output port

### SOURce5: The Subrate Clock Source

KEYWORD	PARAMETER FORM	COMMENTS
SOURce5		
VOLTage		
[:LEVel]		
[:IMMediate]		
[:AMPLitude]	<numeric value>	
[:AMPLitude]?	<NR3>	
:HIGH	<numeric value>	
:HIGH?	<NR3>	
:ECL	---	Event; no query

### OUTPut5: The Subrate Clock Output

KEYWORD	PARAMETER FORM	COMMENTS
OUTPut5		
:COUPling	AC DC	external coupling
:COUPling?	AC DC	external coupling
:TERMination	<numeric value>	
:TERMination?	<NR1>	

## Port 6: the pattern generator clock input port

### SENSe6: The Clock Sense

KEYWORD	PARAMETER FORM	COMMENTS
SENSe6		
:FREQuency		
[:CWI:FIXed]?	<NR3>	query only
:BANDSwitch?	<numeric value>	query only



## Port 10: the pattern generator data (inverted) output port

### SOURce10: The Data (inverted) Source

KEYWORD	PARAMETER	FORM	COMMENTS
SOURce10			
:VOLTage			
[:LEVel]			
[:IMMediate]			
[:AMPLitude]	<numeric value>		
[:AMPLitude]?	<NR3>		
:HIGH	<numeric value>		
:HIGH?	<NR3>		
:TRACk	<boolean>		

### OUTPut10: The Data (inverted) Output

KEYWORD	PARAMETER	FORM	COMMENTS
OUTPut10			
[:STATe]	<boolean>		
[:STATe]?	<boolean>		

---

## Port 11: the pattern generator clock (inverted) output port

### SOURce11: The Clock Source

KEYWORD	PARAMETER	FORM	COMMENTS
SOURce11			
:VOLTage			
[:LEVel]			
[:IMMediate]			
[:AMPLitude]	<numeric value>		
[:AMPLitude]?	<NR3>		
:HIGH	<numeric value>		
:HIGH?	<NR3>		
:TRACk	<boolean>		

## The Error Detector

---

### Port 1: the error detector data input port

#### SENSe1: The Data Sense

KEYWORD	PARAMETER FORM	COMMENTS
[SENSe[1]:]		
PATTERN		
[:SElect]	PRBS<n>   ZSUBstitut<n>   MDENsity<n>   UPATtern<n>	
[:SElect]?	PRBS<n>   ZSUB<n>   MDEN<n>   UPAT	
:ZSUBstitut		
[:ZRUN]	<numeric value>	
[:ZRUN]?	<NR1>	
:MDENsity		
[:DENsity]	<numeric value>	
[:DENsity]?	<NR3>	
:UPATtern<n>		
[:LENGth]	<numeric value>	
[:LENGth]?	<NR1>	
:LABel	<string>	
:LABel?	<string>	
:DATA	[A B,]<block data>	
:DATA?	[A B,]<block data>	
:IDATA	[A B,1<start bit>,<length in bits>,<block data>	
:IDATA?	[A B,]<start bit>,<length in bits>	
:FORMat		
[:DATA]	PACKed,<numeric value>	
[:DATA]?	PACK,<NR1>	
VOLTage		
:ZOTHreshold	<numeric value>	
:ZOTHreshold?	<NR3>	
:AUTO	<boolean>	
:AUTO?	<boolean>	

TMSL Command Definition Quick Reference Guide  
Port 1: the error detector data input port

KEYWORD	PARAMETER FORM	COMMENTS
GATE		
[:STATe]	<boolean>	
[:STATe]?	<boolean>	
:BURSt	<boolean>	
:BURSt?	<boolean>	
:MODE	MANual   SINGle   REPetitive	
:MODE?	MAN   SING   REP	
:MANNer	TIME   ERRors   BITS	
:MANNer?	TIME   ERR   BITS	
:PERiod		
[:TIME]	<numeric value>	
[:TIME]?	<NR1>	
:ERRors	<numeric value>	
:ERRors?	<NR1>	
:BITS	<numeric value>	
:BITS?	<NR3>	
SYNChronisat	ONCE   <boolean>	
SYNChronisat?	<boolean>	
:THReshold	<numeric value>	
:THReshold?	<NR3>	
LOGGing	ONCE   <boolean>	
LOGGing?	<boolean>	
:SQUelch	<boolean>	
:SQUelch?	<boolean>	
:ALARms	<boolean>	
:ALARms?	<boolean>	
:THReshold	<numeric parm>	
:THReshold?	<NR3>	
:DURing		
[:EVENT]	NEVer   ESECond   ERGThrshld	
[:EVENT]?	NEV   ESEC   ERGT	
:END		
[:EVENT]	NEVer   ALWays   NZECount   TERGthrshld	
[:EVENT]?	NEV   ALW   NZEC   TERG	
:REPort	FULL   UREP	
:REPort?	FULL   UREP	
:PORT	RS232   ECONtroller	
:PORT?	RS232   ECON	
:BRATe	<numeric value>	
:BRATe?	<NR1>	

**TMSL Command Definition Quick Reference Guide**  
**Port 1: the error detector data input port**

KEYWORD	PARAMETER FORM	COMMENTS
<b>EYE</b>		
:TCENter   :TCENtre	ONCE   <boolean>	
:TCENter?:   TCENtre?	<boolean>	
:ACENter   :ACENtre	ONCE   <boolean>	
:ACENter?:   ACENtre?	<boolean>	
:WIDTh?	<NR3>	query only
:HEIGHt?	<NR3>	query only
:THReshold	<numeric value>	
:THReshold?	<NR3>	
<b>ELOCation</b>	ONCE	
<b>ELOCation?</b>	<boolean>	
:BEADdress	<numeric value>	
:BEADdress?	<NR1>	
<b>BLOCK</b>	<boolean>	
<b>BLOCK?</b>	<boolean>	
:BSTart	<numeric value>	
:BSTart?	<NR1>	
:BLENgtH	<numeric value>	
:BLENgtH?	<NR1>	

### **INPut1: The Data Input**

KEYWORD	PARAMETER FORM	COMMENTS
<b>INPut[i]</b>		
:POLarity	NORMal   INVerted	
:POLarity	NORM   INV	
:DELay	<numeric value>	
:DELay?	<NR3>	
:TERMination	<numeric value>	
:TERMination?	<NR1>	

---

## Port 2: the error detector clock input port

### SENSe2: The Clock Sense

KEYWORD	PARAMETER FORM	COMMENTS
SENSe2		
:FREQuency		
[:CWI:FIXed]?	<NR3>	Query only

### INPut2: The Clock Input

KEYWORD	PARAMETER FORM	COMMENTS
INPut2		
:TERMination	<numeric value>	
:TERMination?	<NR1>	

---

## Port 7: the error detector trigger output port

### SOURce7: The Trigger Source

KEYWORD	PARAMETER FORM	COMMENTS
SOURce7		
:TRIGger		
[:MODE]	PATtern   DClock	
[:MODE]?	PATT   DCL	

---

## Port 8: the error detector error output port

### OUTPut8: The Errors Output

KEYWORD	PARAMETER FORM	COMMENTS
OUTPut8		
:PLENgtH	RZ   STRetched	
:PLENgtH?	RZ   STR	

---

## The error detector measurement subsystem

KEYWORD	PARAMETER FORM	COMMENTS
FETCh PFETCh		
[:SENSE[i]]		
:ECOUNT		
[:ALL]		
[:FULL]		
[:TOTAL]?	<NR3>	query only
:DELTA?	<NR3>	query only; only refers to FETCh
BIT		
[:TOTAL]?	<NR3>	query only
:DELTA?	<NR3>	query only; only refers to FETCh
:ZASone		
[:TOTAL]?	<NR3>	query only
:OASZero		
[:TOTAL]?	<NR3>	query only
:ERATio		
[:ALL]		
[:FULL]		
[:TOTAL]?	<NR3>	query only
:DELTA?	<NR3>	query only; only refers to FETCh
BIT		
[:TOTAL]?	<NR3>	query only
:DELTA?	<NR3>	query only; only refers to FETCh
:ZASone		
[:TOTAL]?	<NR3>	query only
:OASZero		
[:TOTAL]?	<NR3>	query only
:EINTerval		
:SEConds?	<NR3>	query only
:DSEConds?	<NR3>	query only
:CSEConds?	<NR3>	query only
:MSEConds?	<NR3>	query only

TMSL Command Definition Quick Reference Guide  
The error detector measurement subsystem

KEYWORD	PARAMETER FORM	COMMENTS
:EFINterval		
:SEConds?	<NR3>	query only
:DSEConds?	<NR3>	query only
:CSEConds?	<NR3>	query only
:MSEConds?	<NR3>	query only
:LOSS		
:POWer?	<NR3>	query only
:SYNChronisat?	<NR3>	query only
:G821		
:AVAILability?	<NR3>	query only
:UNAVAILabili?	<NR3>	query only
:SESeconds?	<NR3>	query only
:DMINutes?	<NR3>	query only
:ESEConds?	<NR3>	query only
:GATE		
:ELAPsed?	<NR3>	query only
:LTEXT?	<string>	query only
:SENSe2		
:FREQuency?		
[:CWI:FIXed]?	<NR3>	query only
:BCOunt?	<NR3>	query only
:BANDswitch?	<numeric>	query only

---

## Common Commands

### The DISPLAY subsystem

KEYWORD	PARAMETER FORM	COMMENTS
DISPlay		
:WINDow		
[:RESults]	MAIN OTHer INTerval G821 EYE USER	
[:RESults]?	MAIN OTH INT G821 EYE USER	
CONFig	PATtern DOUtput COUtput EADD SOUtput  TSETup MISC IEYE SAUDio GATing  ELOCation LOGGing PRINter	
CONFig?	PATT DOUT COUT EADD SOUT TSET MISC  IEYE SAUD GAT ELOC LOGG PRIN	
:REPort	PREVious CURRent	
:REPort?	PREV CURR	
:UPAGe		
[:DEFine]	PGCFrequency  EDCFrequency  BCount  ECount  ERATio  DCount  DRATio  ERRors   ZECount  OECount  ZERatio  OERatio   ECBit  ERBit  DECBit  DERBit   ERSeconds  EDSeconds  ECSeconds  EMSeconds  EFSeconds  EFDSeconds	pat gen i/p clock freq err det i/p clock freq bit count error count error ratio delta error count delta error ratio errors  zero as one error count one as zero error count zero as one error ratio one as zero error ratio  bit error count bit error ratio bit delta error count bit delta error ratio  error seconds error deciseconds error centiseconds error milliseconds error free seconds error free deciseconds



TMSL Command Definition Quick Reference Guide  
Common Commands

KEYWORD	PARAMETER FORM	COMMENTS
	EFCSeconds	error free centiseconds
	EFMSeconds	error free milliseconds
	PLSeconds	power loss seconds
	SLSeconds	sync loss seconds
	AVAILability	G.821 availability
	UNAVAILabili	G.821 unavailability
	SESeconds	G.821 severely errored secs
	ERDSeconds	G.821 errored seconds
	DMINutes	G.821 degraded minutes
	BECount	BIG error count
	BERatio	BIG error ratio
	BEDCount	BIG delta error count
	BEDRatio	BIG delta error ratio
	BGELapsed	BIG gating elapsed
	EWIDth	eye width
	EHEight	eye height
	TCENter	eye time center
	VCENter	eye voltage center
	CTHReshold	eye center threshold
	CFRequency	eye center frequency
	CDERatio	eye center delta ratio
	ESTatus	eye status
	EETHreshold	eye edge threshold
	PIDentity	pattern identity
	PGTMode	pat pgen trig mode
	PGTRigger	pat gen trigger
	COAMplitude	clock o/p amplitude
	CBAMplitude	clock bar o/p amplitude
	COHLevel	clock o/p hi-level
	CBHLevel	clock bar o/p hi-level
	COTerm	clock o/p termination
	CBTRack	clock bar tracking
	DOAMplitude	data o/p amplitude
	DBAMplitude	data bar o/p amplitude
	DOHLevel	data o/p hi-level
	DBHLevel	data bar o/p hi-level

TMSL Command Definition Quick Reference Guide  
Common Commands

KEYWORD	PARAMETER FORM	COMMENTS
	DOTerm	data o/p termination
	DOControl	data o/p control
	DBControl	data bar o/p control
	DOPolarity	data o/p polarity
	DODelay	data o/p delay
	DBTRack	data bar tracking
	SDAmplitude	subrate data o/p amplitude
	SDHLevel	subrate data o/p hi-level
	SDTerm	subrate data o/p termination
	SCAmplitude	subrate clock o/p amplitude
	SCHLevel	subrate clock o/p hi-level
	SCTerm	subrate clock o/p termination
	EADD	error add
	EDTMode	err det trig mode
	EDEoutput	err det error output
	ZOTHreshold	0/1 threshold
	DIPolarity	data i/p polarity
	DIDelay	data i/p delay
	DITerm	data i/p termination
	CITerm	clock i/p termination
	SMODE	sync mode
	STHreshold	sync threshold
	GRMode	gating repeat mode
	GDMode	gating duration mode
	GPERiod	gating period
	GREPort	gating report
	GELapsed	gating elapsed
	BEAddress	bit error address
	BSAddress	block start address
	BLENght	block length

TMSL Command Definition Quick Reference Guide  
Common Commands

KEYWORD	PARAMETER FORM	COMMENTS
	LGStatus	logging status
	HCONtroller	HP-IB controller
	ALOGging	alarms logging
	LEReport	log end report
	SStatus	squelch status
	LTHReshold	logging threshold
	LDTRigger	log during trigger
	LETRigger	log end trigger
	SGFRequency	sig gen frequency (with slaved sig gen)
	SGAMplitude	sig gen amplitude (with slaved sig gen)
	SGOutput	sig gen output (with slaved sig gen)
[:DEFine]	<boolean>	
:CLEar	---	event; no query

### The MMEMory subsystem

KEYWORD	PARAMETER FORM	COMMENTS
MMEMory		
:INITialize		
:DELeTe	<file name>	event; no query
:CATalog?	<NR3>,<NR3> {,<file entry>}	query only
:MPResent?	<boolean>	query only
:CPDisk CPDisc	<NR1>	event; no query
:ICPDisk :ICPDisc	<NR1>,<AHALf BHALf,<NR1>,<NR1>	event; no query

### The SYSTEm subsystem

KEYWORD	PARAMETER FORM	COMMENTS
SYSTEm		
:BEEPer		
[:IMMediate]	[<freq>[,<time> [,<vol>]]]	parms no effect
:STATe	<boolean>	
:STATe?	<boolean>	
:VOLume	<numeric value>	
:VOLume	<NR3>	

**TMSL Command Definition Quick Reference Guide**  
**Common Commands**

KEYWORD	PARAMETER FORM	COMMENTS
:ERror?	<NR1>,<string>	query only
:KLOCK	<boolean>	
:KLOCK?	<boolean>	
:PRESet :PRESet<n>	---	event; no query
:PTHrough		
[:STRing]	<string>	
[:STRing]?	<string>	
:VERsion?	<NR2>	query only
:DATE	<year>,<month>,<day>	
:DATE?	<year>,<month>,<day>	
:TIME	<hour>,<minute>,<second>	
:TIME?	<hour>,<minute>,<second>	
:FREvision		
[:CPRocessor]		
[:APPLication]?	<string>	query only
:BOOT?	<string>	query only
:MPRocessor		
[:APPLication]?	<string>	query only
:BOOT?	<string>	query only
:FUPDate	CAPPLication MAPPLication	

**The STATus subsystem**

KEYWORD	PARAMETER FORM	COMMENTS
STATUS		
:OPERation		
[:EVENT]?	<NR1>	query only
:CONDition?	<NR1>	query only
:ENABle	<NRf>	
:ENABle?	<NR1>	
:PTRansition	<NRf>	
:PTRansition?	<NR1>	
:NTRansition	<NRf>	
:NTRansition?	<NR1>	
:QUEStionable		
[:EVENT]?	<NR1>	query only
:CONDition?	<NR1>	query only
:ENABle	<NRf>	
:ENABle?	<NR1>	
:PTRansition	<NRf>	
:PTRansition?	<NR1>	
:NTRansition	<NRf>	
:NTRansition?	<NR1>	

TMSL Command Definition Quick Reference Guide  
Common Commands

KEYWORD	PARAMETER FORM	COMMENTS
:CLOsS		query only
[:EVENT]?	<NR1>	query only
:CONDition?	<NR1>	
:ENABle	<NRf>	
:ENABle?	<NR1>	
:PTRansition	<NRf>	
:PTRansition?	<NR1>	
:NTRansition	<NRf>	
:NTRansition?	<NR1>	
:PRESet	---	event; no query
:FAILure		
[:EVENT]?	<NR1>	query only

## Port 9: the slaved MMS signal generator clock output port

### SOURce9: The Clock Source

KEYWORD	PARAMETER FORM	COMMENTS
SOURce9		
:IDN?	<string>	query only
:FREQuency		
[:CWI:FIXed]	<numeric value>	
[:CWI:FIXed]?	<NR3>	
:STEP		
[:INCRement]	<numeric value>	
[:INCRement]?	<NR3>	
:POWer		
[:LEVel]		
[:IMMediate]		
[:AMPLitude]	<numeric value>	
[:AMPLitude]?	<NR3>	
:OUTPut		
[STATE]	<boolean>	
[STATE]?	<boolean>	

## IEEE Common Commands

### Mandatory Commands

KEYWORD	PARAMETER FORM	COMMENTS
*CLS	---	event; no query
*ESE	<NRf>	
*ESE?	<NR1>	
*ESR?	<NR1>	query only
*IDN?	<string>	query only
*OPC	---	
*OPC?	<NR1>	
*RST	---	event; no query
*SRE	<NRf>	
*SRE?	<NR1>	
*STB?	<NR1>	query only
*TST?	<NR1>	query only
*WAI	---	

### Optional Commands

KEYWORD	PARAMETER FORM	COMMENTS
*OPT?	<NR1>	Query only Two fields: 1. UHF UHG UHH 2. UHJ 0
*PSC	<NRf>	
*PSC?	<NR1>	
*RCL	<NRf>	event; no query
*SAV	<NRf>	event; no query





---

**SCPI Conformance  
Information**

## Introduction

This section details how the HP 71612 Series of Gb/s Testers conform to *Standard Commands for Programmable Instruments (SCPI)*. It lists separately:

- The SCPI version to which the instruments comply.
- The commands confirmed by SCPI.
- The commands approved by SCPI.
- The commands which are not yet part of the SCPI definition.

---

## SCPI Version

The HP 71612 Series of Gb/s Testers complies with SCPI-1990.0

---

## SCPI Confirmed Commands

The following commands are confirmed by SCPI:

```
[SOURCE[1]:]  
  VOLTage  
    [ :LEVel]  
      [ :IMMediate]  
        [ :AMPLitude]  
        [ :AMPLitude]?  
        :HIGH  
        :HIGH?  
        :ATTenuation  
        :ATTenuation?  
  PATtern  
    :FORMAT  
      [ :DATA]  
      [ :DATA]?
```

SCPI Conformance Information  
SCPI Confirmed Commands

SOURce2

:FREQuency  
  [:CW|:FIXed]?  
:VOLTagE  
  [:LEVel]  
    [:IMMediate]  
      [:AMPLitude]  
      [:AMPLitude]?  
      [:HIGH]  
      [:HIGH]?  
:ATTenuation  
:ATTenuation?

OUTPut[1]

  [:STATE]  
  [:STATE]?  
:COUpling  
:COUpling?

OUTPut2

  :COUpling  
  :COUpling?

SOURce4

:VOLTagE  
  [:LEVel]  
    [IMMediate]  
      [:AMPLitude]  
      [:AMPLitude]?  
      :HIGH  
      :HIGH?

OUTPut4

  :COUpling  
  :COUpling?

SCPI Conformance Information  
SCPI Confirmed Commands

SOURce5  
  :VOLTage  
    [:LEVel]  
      [IMMediate]  
        [:AMPLitude]  
        [:AMPLitude]?  
        :HIGH  
        :HIGH?

OUTPut5  
  :COUPling  
  :COUPling?

SENSe6  
  :FREQuency  
  [:CW|:FIXed]?

SOURce10  
  :VOLTage  
    [:LEVel]  
      [IMMediate]  
        [:AMPLitude]  
        [:AMPLitude]?  
        :HIGH  
        :HIGH?

OUTPut10  
  [:STATe]  
  [:STATe]?

SOURce11  
  :VOLTage  
    [:LEVel]  
      [IMMediate]  
        [:AMPLitude]  
        [:AMPLitude]?  
        :HIGH  
        :HIGH?

SENSe2  
  :FREQuency  
  [:CW|:FIXed]?

SCPI Conformance Information  
SCPI Confirmed Commands

SOURce9

:IDN?  
:FREQuency  
  [:CW|FIXed]  
  [:CW|FIXed]?  
  :STEP  
    [:INCRement]  
    [:INCRement]?  
:POWER  
  [:LEVEl]  
  [:IMMediate]  
  [:AMPLitude]  
  [:AMPLitude]?  
:OUTPut  
  [STATE]  
  [STATE]?

MMEMemory

:INITialize  
:DELeTe  
:CATalogue?

[SENSe[1]:]

PATtern  
  :FORMat  
    [:DATA]  
    [:DATA]?

SYSTEM

:BEEPer  
  [:IMMediate]  
:ERRor?  
:KLOCK  
:KLOCK?  
:PRESet  
:VERSion?  
:DATE  
:DATE?  
:TIME  
:TIME?

SCPI Conformance Information  
SCPI Confirmed Commands

STATus

:QUEStionable  
[:EVENT]?  
:CONDition  
:CONDition?  
:ENABle  
:ENABle?  
:PTRansition  
:PTRansition?  
:NTRansition  
:NTRansition?  
:PRESet  
:OPERation  
[:EVENT]?  
:CONDition  
:CONDition?  
:ENABle  
:ENABle?  
:PTRansition  
:PTRansition?  
:NTRansition  
:NTRansition?  
:PRESet

\*CLS  
\*ESE  
\*ESE?  
\*ESR?  
\*IDN?  
\*OPC  
\*OPC?  
\*RST  
\*SRE  
\*SRE?  
\*STB?  
\*TST?  
\*WAI  
\*OPT?  
\*PSC  
\*PSC?  
\*RCL  
\*SAV

## SCPI Approved Commands

There are no commands in this category.

---

## Non-SCPI Commands

The following commands are not yet part of the SCPI standard:

```
[SOURCE[1]:]  
  PATTERN  
    [:SELECT]  
    [:SELECT]?  
  
    :ZSUBstitut  
      [:ZRUN]  
      [:ZRUN]?  
  
    :MDENSITY  
      [:DENSITY3]  
      [:DENSITY]?  
  
    :UPATTERN<n>  
      [:LENGTH]  
      [:LENGTH]?  
      :LABEL  
      :LABEL?  
      :USE  
      :USE?  
      :DATA  
      :DATA?  
      :IDATA  
      :IDATA?  
      :LMODified?
```

SCPI Conformance Information  
Non-SCPI Commands

:APCHange  
:SOURce  
:SOURce?  
:MODE  
:MODE?  
:SElect  
:SElect?  
:IBHalf

:EADdition  
:SOURce  
:SOURce?  
:RATE  
:RATE?

:VOLTagage  
:ECL

OUTPut[1]  
:POLarity  
:POLarity?  
:DELay  
:DELay?  
:TERMination  
:TERMination?

SOURce2  
:VOLTagage  
:ECL

OUTPut2  
:TERMination  
:TERMination?



SCPI Conformance Information  
Non-SCPI Commands

SOURce3

:TRIGger  
  [:MODE]  
  [:MODE]?  
  :DCCRatIo  
  :DCCRatIo?  
  :CTDRatIo?  
  :PRBS<n>  
  :PRBS<n>?  
  :ZSUBstitut<n>  
  :ZSUBstitut<n>?  
  :MDENsity<n>  
  :MDENsity<n>?  
  :UPATtern<n>  
  :UPATtern<n>?  
  :APATtern<n>  
  :APATtern<n>?

SOURce4

VOLTage  
  :ECL

OUTPut4

:TERMination  
:TERMination?

SOURce5

VOLTage  
  :ECL

OUTPut5

:TERMination  
:TERMination?

SENSe6

:BANDswitch?

SOURce10

:VOLTage  
  :TRACk

SCPI Conformance Information  
Non-SCPI Commands

```
SOURcell
  :VOLTage
    :TRACk

SENSe1:
  PATtern
    [:SElect]
    [:SElect]?

    :ZSUBstitut
      [:ZRUN]
      [:ZRUN]?

    :MDENsity
      [:DENsity]
      [:DENsity]?

    :UPATtern<n>
      [:LENGth]
      [:LENGth]?
      :LABel
      :LABel?
      :DATA
      :DATA?
      :IDATa
      :IDATa?

  VOLTage
    :ZOTHreshold
    :ZOTHreshold?
    :AUTO
    :AUTO?
```

SCPI Conformance Information  
Non-SCPI Commands

GATE

[ :STATE]  
[ :STATE]?  
:BURSt  
:BURSt?  
:MODE  
:MODE?  
:MANNer  
:MANNer?  
:PERiod  
    [ :TIME]  
    [ :TIME]?  
    :ERRors  
    :ERRors?  
    :BITs  
    :BITs?

SYNChronisat

SYNChronisat?  
    :THReshold  
    :THReshold?

LOGGing

LOGGing?  
    :SQUelch  
    :SQUelch?  
    :ALARms  
    :ALARms?  
    :THReshold  
    :THReshold?  
    :DURING  
        [ :EVENT]  
        [ :EVENT]?  
    :END  
        [ :EVENT]  
        [ :EVENT]?  
        :REPort  
        :REPort?  
    :PORT  
    :BRATe

SCPI Conformance Information  
Non-SCPI Commands

EYE

:TCENter | :TCENtre  
:TCENter?: | TCENtre?  
:ACENter | :ACENtre  
:ACENter?: | ACENtre?  
:WIDTh?  
:HEIGHt?  
:THReshold  
:THReshold?

ELOCation

ELOCation?  
:BEADdress  
:BEADdress?

BLOCK

BLOCK?  
:BStart  
:BStart?  
:BLENght  
:BLENght?

INPut[1]

:POLarity  
:POLarity  
:DELay  
:DELay?  
:TERMination  
:TERMination?

SENSe2

:BRATe?

INPut2

:TERMination  
:TERMination?

SOURce7

:TRIGger  
[ :MODE ]  
[ :MODE ]?

SCPI Conformance Information  
Non-SCPI Commands

OUTPut8

:PLENgtH  
:PLENgtH?

FETCh|PFETCh

[ :SENSe[1]]  
:ECOut  
  [ :ALL]  
    [ :FULL]  
      [ :TOTAl]?  
      :DELTA?  
    BIT  
      [ :TOTAl]?  
      :DELTA?  
  :ZASone  
    [ :TOTAl]?  
  :OASZero  
    [ :TOTAl]?

:ERATio  
  [ :ALL]  
    [ :FULL]  
      [ :TOTAl]?  
      :DELTA?  
    BIT  
      [ :TOTAl]?  
      :DELTA?  
  :ZASone  
    [ :TOTAl]?  
  :OASZero  
    [ :TOTAl]?

:EINTerval  
  :SEConds?  
  :DSEConds?  
  :CSEConds?  
  :MSEConds?

:EFINTerval  
  :SEConds?  
  :DSEConds?  
  :CSEConds?  
  :MSEConds?

SCPI Conformance Information  
Non-SCPI Commands

:LOSS  
:POWER?  
:SYNChronisat?

:G821  
:AVAILability?  
:UNAVAILabili?  
:SECONDS?  
:DMINutes?  
:ESECONDS?

:GATE  
:ELAPsed?  
:LTEXT?

:SENSe2  
:BCOUNT?  
:BANDswitch?

DISPlay

:WINDow  
[:RESults]  
[:RESults]?  
CONFig  
CONFig?  
:REPort  
:REPort?  
:UPAGe  
[:DEFine]  
:CLEAr

MMEMory

:MPResent?  
:CPDisk|CPDisc  
:ICPDisk|:ICPDisc

SCPI Conformance Information  
Non-SCPI Commands

SYSTEM

:FREVISION  
  [:CProcessor]  
    [:APPLICATION]?  
    :BOOT?  
  :MPROCESSOR  
    [:APPLICATION]?  
    :BOOT?  
:FUPDATE

STATUS

:QUESTIONABLE  
  :CLOSS  
    [:EVENT]?  
    :CONDITION?  
    :ENABLE  
    :ENABLE?  
    :PTRANSITION  
    :PTRANSITION?  
    :NTRANSITION  
    :NTRANSITION?  
  
:PRESET  
:FAILURE  
  [:EVENT]?





---

**SCPI Messages**

## SCPI Messages

### No Error

### Introduction

The system-defined error/event numbers are chosen on an enumerated (“1 of N”) basis. The SCPI defined error/event numbers and the <error description> portions of the ERRor query response are listed here. The first error/event described in each class (for example, -100, -200, -300, -400) is a “generic” error. In selecting the proper error/event number to report, more specific error/event codes are preferred, and the generic error/event is used only if the others are inappropriate.

---

### No Error

This message indicates that the device has no errors.

#### 0 No Error

The queue is completely empty. Every error/event in the queue has been read or the queue was purposely cleared by power-on, \*CLS, etc.

## Command Errors [-199, -100]

An <error/event number> in the range [-199, -100] indicates that an *IEEE 488.2* syntax error has been detected by the instrument's parser. The occurrence of any error in this class should cause the command error bit (bit 5) in the event status register (*IEEE 488.2*, section 11.5.1) to be set. One of the following events has occurred:

- An *IEEE 488.2* system error has been detected by the parser. That is, a controller-to-device message was received which is in violation of the *IEEE 488.2* standard. Possible violations include a data element which violates the device listening formats or whose type is unacceptable to the device.
- An unrecognized header was received. Unrecognized headers include incorrect device-specific headers and incorrect or unimplemented *IEEE 488.2* common commands.
- A Group Execute Trigger (GET) was entered into the input buffer inside of an *IEEE 488.2* <PROGRAM MESSAGE>.

Events that generate command errors shall not generate execution errors, device-specific errors, or query errors.

### -100 Command error

This is the generic syntax error for devices that cannot detect more specific errors. This code indicates only that a Command Error as defined in *IEEE 488.2*, 11.5.1.1.4 has occurred.

### -101 Invalid character

A syntactic element contains a character which is invalid for that type; for example, a header containing an ampersand, SETUP&. This error might be used in place of errors -114, -121, -141, and perhaps some others.

### -102 Syntax error

An unrecognized command or data type was encountered; for example, a string was received when the device does not accept strings.

### -103 Invalid separator

The parser was expecting a separator and encountered an illegal character; for example, the semicolon was omitted after a program message unit, \*EMC 1:CH1:VOLTS 5.

### -104 Data type error

The parser recognized a data element different than one allowed; for example, numeric or string data was expected but block data was encountered.

**SCPI Messages**  
**Command Errors [-199, -100]**

**-105 GET not allowed**

A Group Execute Trigger was received within a program message (see *IEEE 488.2*, 7.7).

**-108 Parameter not allowed**

More parameters were received than expected for the header; for example, the \*EMC common command only accepts one parameter, so receiving \*EMC 0,1 is not allowed.

**-109 Missing parameter**

Fewer parameters were received than required for the header; for example, the \*EMC common command requires one parameter, so receiving \*EMC is not allowed.

**-110 Command header error**

An error was detected in the header. This error message should be used when the device cannot detect the more specific errors described for errors -111 through -119.

**-111 Header separator error**

A character which is not a legal header separator was encountered while parsing the header; for example, no white space followed the header, thus \*GMC“MACRO” is an error.

**-112 Program mnemonic too long**

The header contains more than twelve characters (see *IEEE 488.2*, 7.6.1.4.1).

**-113 Undefined header**

The header is syntactically correct, but it is undefined by this specific device; for example, \*XYZ is not defined for any device.

**-114 Header suffix out of range**

Indicates that a nonheader character has been encountered in what the parser expects is a header element.

**-120 Numeric data error**

This error, as well as errors -121 through -129, are generated when parsing a data element which appears to be numeric, including the nondecimal numeric types. This particular error message should be used if the device cannot detect a more specific error.

**-121 Invalid character in number**

An invalid character for the data type being parsed was encountered; for example, an alpha in a decimal numeric or a “9” in octal data.

**SCPI Messages**  
**Command Errors [-199, -100]**

**-123 Exponent too large**

The magnitude of the exponent was larger than 32000 (see *IEEE 488.2*, 7.7.2.4.1).

**-124 Too many digits**

The mantissa of a decimal numeric data element contained more than 255 digits excluding leading zeros (see *IEEE 488.2*, 7.7.2.4.1).

**-128 Numeric data not allowed**

A legal numeric data element was received, but the device does not accept one in this position for the header.

**-130 Suffix error**

This error, as well as errors -131 through -139, are generated when parsing a suffix. This particular error message should be used if the device cannot detect a more specific error.

**-131 Invalid suffix**

The suffix does not follow the syntax described in *IEEE 488.2*, 7.7.3.2, or the suffix is inappropriate for this device.

**-134 Suffix too long**

The suffix contained more than 12 characters (see *IEEE 488.2*, 7.7.3.4).

**-138 Suffix not allowed**

A suffix was encountered after a numeric element which does not allow suffixes.

**-140 Character data error**

This error, as well as errors -141 through -149, are generated when parsing a character data element. This particular error message should be used if the device cannot detect a more specific error.

**-141 Invalid character data**

Either the character data element contains an invalid character or the particular element received is not valid for the header.

**-144 Character data too long**

The character data element contains more than twelve characters (see *IEEE 488.2*, 7.7.1.4).

**-148 Character data not allowed**

A legal character data element was encountered where prohibited by the device.

**SCPI Messages**  
**Command Errors [-199, -100]**

**-150 String data error**

This error, as well as errors -151 through -159, are generated when parsing a string data element. This particular error message should be used if the device cannot detect a more specific error.

**-151 Invalid string data**

A string data element was expected, but was invalid for some reason (see *IEEE 488.2*, 7.7.5.2); for example, an END message was received before the terminal quote character.

**-158 String data not allowed**

A string data element was encountered but was not allowed by the device at this point in parsing.

**-160 Block data error**

This error, as well as errors -161 through -169, are generated when parsing a block data element. This particular error message should be used if the device cannot detect a more specific error.

**-161 Invalid block data**

A block data element was expected, but was invalid for some reason (see *IEEE 488.2*, 7.7.6.2); for example, an END message was received before the length was satisfied.

**-168 Block data not allowed**

A legal block data element was encountered but was not allowed by the device at this point in parsing.

**-170 Expression error**

This error, as well as errors -171 through -179, are generated when parsing an expression data element. This particular error message should be used if the device cannot detect a more specific error.

**-171 Invalid expression**

The expression data element was invalid (see *IEEE 488.2*, 7.7.7.2); for example, unmatched parentheses or an illegal character.

**-178 Expression data not allowed**

A legal expression data was encountered but was not allowed by the device at this point in parsing.

**SCPI Messages**  
**Command Errors [-199, -100]**

**-180 Macro error**

This error, as well as errors -181 through -189, are generated when defining a macro or executing a macro. This particular error message should be used if the device cannot detect a more specific error.

**-181 Invalid outside macro definition**

Indicates that a macro parameter placeholder ( $\$<number>$ ) was encountered outside of a macro definition.

**-183 Invalid inside macro definition**

Indicates that the program message unit sequence, sent with a \*DDT or \*DMC command, is syntactically invalid (see 10.7.6.3).

**-184 Macro parameter error**

Indicates that a command inside the macro definition had the wrong number or type of parameters.

## Execution Errors [-299, -200]

An <error/event number> in the range [-299, -200] indicates that an error has been detected by the instrument's execution control block. The occurrence of any error in this class should cause the execution error bit (bit 4) in the event status register (*IEEE 488.2*, section 11.5.1) to be set. One of the following events has occurred:

- A <PROGRAM DATA> element following a header was evaluated by the device as outside of its legal input range or is otherwise inconsistent with the device's capabilities.
- A valid program message could not be properly executed due to some device condition.

Execution errors shall be reported by the device after rounding and expression evaluation operations have taken place. Rounding a numeric data element, for example, shall not be reported as an execution error. Events that generate execution errors shall not generate Command Errors, device-specific errors, or Query Errors.

### **-200 Execution error**

This is the generic syntax error for devices that cannot detect more specific errors. This code indicates only that an Execution Error as defined in *IEEE 488.2*, 11.5.1.1.5 has occurred.

### **-201 Invalid while in local**

Indicates that a command is not executable while the device is in local due to a hard local control (see *IEEE 488.2*, 5.6.1.5); for example, a device with a rotary switch receives a message which would change the switches state, but the device is in local so the message can not be executed.

### **-202 Settings lost due to rtl**

Indicates that a setting associated with a hard local control (see *IEEE 488.2*, 5.6.1.5) was lost when the device changed to LOGS from REMS or to LWLS from RWLS.

### **-210 Trigger error**

### **-211 Trigger ignored**

Indicates that a GET, \*TRG, or triggering signal was received and recognized by the device but was ignored because of device timing considerations; for example, the device was not ready to respond. Note: a DTO device always ignores GET and treats \*TRG as a Command Error.



**SCPI Messages**  
**Execution Errors [-299, -200]**

**-212 Arm ignored**

Indicates that an arming signal was received and recognized by the device but was ignored.

**-213 Init ignored**

Indicates that a request for a measurement initiation was ignored as another measurement was already in progress.

**-214 Trigger deadlock**

Indicates that the trigger source for the initiation of a measurement is set to GET and subsequent measurement query is received. The measurement cannot be started until a GET is received, but the GET would cause an INTERRUPTED error.

**-215 Arm deadlock**

Indicates that the arm source for the initiation of a measurement is set to GET and subsequent measurement query is received. The measurement cannot be started until a GET is received, but the GET would cause an INTERRUPTED error.

**-220 Parameter error**

Indicates that a program data element related error occurred. This error message should be used when the device cannot detect the more specific errors described for errors -221 through -229.

**-221 Setting conflict**

Indicates that a legal program data element was parsed but could not be executed due to the current device state (see *IEEE 488.2*, 6.4.5.3 and 11.5.1.1.5.)

**-222 Data out of range**

Indicates that a legal program data element was parsed but could not be executed because the interpreted value was outside the legal range as defined by the device (see *IEEE 488.2*, 11.5. 1. 1.5.)

**-223 Too much data**

Indicates that a legal program data element of block, expression, or string type was received that contained more data than the device could handle due to memory or related device-specific requirements.

**-224 Illegal parameter value**

Used where exact value, from a list of possibles, was expected.

**SCPI Messages**  
**Execution Errors [-299, -200]**

**-230 Data corrupt or stale**

Possibly invalid data; new reading started but not completed since last access.

**-231 Data questionable**

Indicates that measurement accuracy is suspect.

**-240 Hardware error**

Indicates that a legal program command or query could not be executed because of a hardware problem in the device. Definition of what constitutes a hardware problem is completely device-specific. This error message should be used when the device cannot detect the more specific errors described for errors -241 through -249.

**-241 Hardware missing**

Indicates that a legal program command or query could not be executed because of missing device hardware; for example, an option was not installed. Definition of what constitutes missing hardware is completely device-specific.

**-250 Mass storage error**

Indicates that a mass storage error occurred. This error message should be used when the device cannot detect the more specific errors described for errors -251 through -259.

**-251 Missing mass storage**

Indicates that a legal program command or query could not be executed because of missing mass storage; for example, an option that was not installed. Definition of what constitutes missing mass storage is device-specific.

**-252 Missing media**

Indicates that a legal program command or query could not be executed because of a missing media; for example, no disk. The definition of what constitutes missing media is device-specific.

**-253 Corrupt media**

Indicates that a legal program command or query could not be executed because of corrupt media; for example, bad disk or wrong format. The definition of what constitutes corrupt media is device-specific.

**-254 Media full**

Indicates that a legal program command or query could not be executed because the media was full; for example, there is no room on the disk. The definition of what constitutes a full media is device-specific.

**SCPI Messages**  
**Execution Errors [-299, -200]**

**-255 Directory full**

Indicates that a legal program command or query could not be executed because the media directory was full. The definition of what constitutes a full media directory is device-specific.

**-256 File name not found**

Indicates that a legal program command or query could not be executed because the file name on the device media was not found; for example, an attempt was made to read or copy a nonexistent file. The definition of what constitutes a file not being found is device-specific.

**-257 File name error**

Indicates that a legal program command or query could not be executed because the file name on the device media was in error; for example, an attempt was made to copy to a duplicate file name. The definition of what constitutes a file name error is device-specific.

**-258 Media protected**

Indicates that a legal program command or query could not be executed because the media was protected; for example, the write-protect tab on a disk was present. The definition of what constitutes protected media is device-specific.

**-260 Expression error**

Indicates that an expression program data element related error occurred. This error message should be used when the device cannot detect the more specific errors described for errors -261 through -269.

**-261 Math error in expression**

Indicates that a syntactically legal expression program data element could not be executed due to a math error; for example, a divide-by-zero was attempted. The definition of math error is device-specific.

**-270 Macro error**

Indicates that a macro-related execution error occurred. This error message should be used when the device cannot detect the more specific errors described for errors -271 through -279.

**-271 Macro syntax error**

Indicates that a syntactically legal macro program data sequence, according to *IEEE 488.2*, 10.7.2, could not be executed due to a syntax error within the macro definition (see *IEEE 488.2*, 10.7.6.3.)

**SCPI Messages**  
**Execution Errors [-299, -200]**

**-272 Macro execution error**

Indicates that a syntactically legal macro program data sequence could not be executed due to some error in the macro definition (see *IEEE 488.2*, 10.7.6.3.)

**-273 Illegal macro label**

Indicates that the macro label defined in the \*DMC command was a legal string syntax but could not be accepted by the device (see *IEEE 488.2*, 10.7.3 and 10.7.6.2); for example, the label was too long, the same as a common command header, or contained invalid header syntax.

**-274 Macro parameter error**

Indicates that the macro definition improperly used a macro parameter placeholder (see *IEEE 488.2*, 10.7.3).

**-275 Macro definition too long**

Indicates that a syntactically legal macro program data sequence could not be executed because the string or block contents were too long for the device to handle (see *IEEE 488.2*, 10.7.6. 1).

**-276 Macro recursion error**

Indicates that a syntactically legal macro program data sequence could not be executed because the device found it to be recursive (see *IEEE 488.2*, 10.7.6.6).

**-277 Macro redefinition not allowed**

Indicates that a syntactically legal macro label in the \*DMC command could not be executed because the macro label was already defined (see *IEEE 488.2*, 10.7.6.4).

**-278 Macro header not found**

Indicates that a syntactically legal macro label in the \*GMC? query could not be executed because the header was not previously defined.

**-280 Program error**

Indicates that a downloaded program-related execution error occurred. This error message should be used when the device cannot detect the more specific errors described for errors -281 through -289.

---

**NOTE**

A downloaded program is used to add algorithmic capability to a device. The syntax used in the program and the mechanism for downloading a program is device-specific.

---

**SCPI Messages**  
**Execution Errors [-299, -200]**

**-281 Cannot create program**

Indicates that an attempt to create a program was unsuccessful. A reason for the failure might include not enough memory.

**-282 Illegal program name**

The name used to reference a program was invalid; for example, redefining an existing program, deleting a nonexistent program, or in general, referencing a nonexistent program.

**-283 Illegal variable name**

An attempt was made to reference a nonexistent variable in a program.

**-284 Program currently running**

Certain operations dealing with programs may be illegal while the program is running; for example, deleting a running program might not be possible.

**-285 Program syntax error**

Indicates that a syntax error appears in a downloaded program. The syntax used when parsing the downloaded program is device-specific.

**-286 Program runtime error**

## Query Errors [-499, -400]

An <error/event number> in the range [-499, -400] indicates that the output queue control of the instrument has detected a problem with the message exchange protocol described in *IEEE 488.2*, chapter 6. The occurrence of any error in this class should cause the query error bit (bit 2) in the event status register (*IEEE 488.2*, section 11.5.1) to be set. These errors correspond to message exchange protocol errors described in *IEEE 488.2*, section 6.5. One of the following is true:

- An attempt is being made to read data from the output queue when no output is either present or pending.
- Data in the output queue has been lost.

Events that generate query errors shall not generate command errors, execution errors, or device-specific errors; see the other error definitions in this section.

### **-400 Query error**

This is the general query error for devices that cannot detect more specific errors. This code indicates only that a Query Error, as defined in *IEEE 488.2*, 11.5.1.1.7 and 6.3, has occurred.

### **-410 Query INTERRUPTED**

Indicates that a condition causing an INTERRUPTED Query error occurred (see *IEEE 488.2*, 6.3.2.3); for example, a query followed by DAB or GET before a response was completely sent.

### **-420 Query UNTERMINATED**

Indicates that a condition causing an UNTERMINATED Query error occurred (see *IEEE 488.2*, 6.3.2.2); for example, the device was addressed to talk and an incomplete program message was received.

### **-430 Query DEADLOCKED**

Indicates that a condition causing a DEADLOCKED Query error occurred (see *IEEE 488.2*, 6.3.1.7); for example, both input buffer and output buffer are full and the device cannot continue.

### **-440 Query UNTERMINATED after indefinite response**

Indicates that a query was received in the same program message after a query requesting an indefinite response was executed (see *IEEE 488.2*, 6.5.7.5.7.)

---

**Program Examples**

### Introduction

This appendix provides example programs on clock stabilization, testing and gaining pattern synchronization and clock to data alignment.

### Clock Stabilization

The following example explains the use of BANDswitch? to establish end of “settling time” following a frequency change. The following code extract gives an example of the use of the functions in the RMB-UX basic language example program given on page 7-3. This indicates that only the “FNBertFreqSetld” function need be called directly with the other functions being called at a lower level.

```
80 REAL    SrcFreq
90 INTEGER Settled
130 Isc     = 7      ! HPIB i/f select code
140 Instradr = 8     ! 70843 HSBERT's HPIB address
350 ASSIGN @Instr TO 100*Isc+Instradr
500 SrcFreq=2.4E+9
600 ! configure clock source (This may be independently controlled over HPIB or,
605 ! when using an MMS
610 ! source configured as a "slave" to the BERT, via the BERT's
615 ! "SOURCE9:FREQ" command.)
620 CALL SetSrcFreq( SrcFreq ) ! configure clock source (may be independently
625                               ! controlled over HPIB
630
640 ! await BERT establishing its settings for the new frequency.
650 Settled = FNBertFreqSetld( @Instr, SrcFreq )
660 !
670 IF ( Settled ) THEN . . .
        make BERT measurements
800 ELSE
        Report that BERT's generator or detector configuration did not
        stabilise within the maximum expected time (~30 seconds).
        The outcome should cause termination of testing until the cause
        is understood. Investigate the cabling of the "CLOCK IN"
        and "CLOCK OUT" ports and observe the BERTs behaviour on manually
        repeating the configuration changes.
1000 END IF
```



## Program Examples

### RMB-UX Basic Language Example of the Use of BANDswitch?

```
9570 DEF FNInstrid$( @Bert )
9580   DIM Id$[100]
9590   OUTPUT @Bert;"*IDN?"
9600   ENTER @Bert;Id$
9610   RETURN Id$
9620 FNEND
9630 !
9640 !           FNBertPgPresent
9650 !
9660 ! This function returns 1 (true) when the HP70843 BERT
9670 ! controlled via i/o path @Bert has a pattern generator
9680 ! module installed and returns 0 (false) otherwise.
9690 !
9700 DEF FNBertPgPresent( @Bert )
9710   DIM BertOpt$[1],Id$[100]
9720   Id$ = FNInstrid$( @Bert )
9730   BertOpt$ = Id$[22,22]
9740   RETURN (( BertOpt$="A" ) OR ( BertOpt$="B" ))
9750 FNEND
9760 !
9770 !           FNBertEdPresent
9780 !
9790 ! This function returns 1 (true) when the HP70843 BERT
9800 ! controlled via i/o path @Bert has an error detector
9810 ! module installed and returns 0 (false) otherwise.
9820 !
9830 DEF FNBertEdPresent( @Bert )
9840   DIM BertOpt$[1],Id$[100]
9850   Id$ = FNInstrid$( @Bert )
9860   BertOpt$ = Id$[22,22]
9870   RETURN (( BertOpt$="A" ) OR ( BertOpt$="C" ))
9880 FNEND
```

## Program Examples

```
9890 !
9900 !     FNClkBandok
9910 !
9920 ! Given the BERT's response to the BANDswitch? query
9930 ! and the known actual clock input frequency
9940 ! (i.e. not the BERT's measured value) this function
9950 ! returns 1 when the Band indicates that the BERT's
9960 ! clock system control state has stabilised following
9970 ! a change in the clock input frequency or level, and
9980 ! returns 0 otherwise to indicate that the BERT is not
9990 ! yet quiescent.
10000 !
10010 ! Notes:
10020 ! a) when 2.9GHz < Freq < 3.1 GHz, Band 1 or 2 is OK
10030 ! b) when 5.9GHz < Freq < 6.1 GHz, Band 2 or 3 is OK
10040 ! c) when           Freq > 13.1 GHz, Band 0 implies no clk-data
10050 !                               delay control available.
10060 ! d) a tolerance of +/-1MHz is used on the given Freq.
10070 !
10080 DEF FNClkBandok(REAL Freq,INTEGER Band)
10090     REAL    Ghz
10100     INTEGER Ok
10110     Ghz = 1.0E+9    ! 1 GHz
10120     SELECT Band
10130         CASE 0
10140             Ok = ((Freq=0) OR (Freq>13.099*Ghz))
10150         CASE 1
10160             Ok = ((Freq>0) AND (Freq<3.101*Ghz))
10170         CASE 2
10180             Ok = ((Freq>=2.899+Ghz) AND (Freq<6.101*Ghz))
10190         CASE 3
10200             Ok = ((Freq>=5.899~Ghz) AND (Freq<13.101*Ghz))
10210         CASE ELSE
10220             Ok = 0    ! False
10230     END SELECT
10240     RETURN Ok
10250 FNEND
10260 !
10270 !     FNFreqInTol
10280 !
10290 ! This function returns 1 (true) when MeasFreq is within 1MHz
10300 ! of ActualFreq and 0 (false) otherwise
10310 !
10320 DEF FNFreqInTol( REAL ActualFreq, MeasFreq )
10330     RETURN ((MeasFreq<ActualFreq+1.0E+6) AND (MeasFreq>ActualFreq-1.0E+6))
10340 FNEND
10350 !
```

## Program Examples

```
10360 !           FNBertFreqSetId
10370 !
10380 ! This function should be called following any change of frequency
10390 ! at the "CLOCK IN" port of the HP70843 BERT's pattern generator
10400 ! or error detector modules.
10410 !
10420 ! This function returns 1 (true) when the pattern generator
10430 ! and/or error detector's clock system configurations and the
10440 ! measured frequencies are within 1MHz of the given "ActualFreq".
10450 ! If either of the clock system bands or measured frequencies
10460 ! fails to reach the expected value within 30 seconds this function
10470 ! returns 0 (false).
10480 !
10490 DEF FNBertFreqSetId( @Bert, REAL ActualFreq )
10500 !
10510     INTEGER Band,Settled,AbortTime,MaxNoOfWaits,AttemptNo,Abort
10520     REAL MeasFreq,WaitTime
10530     DIM Id$(80)
10540     AbortTime     = 30           ! seconds
10550     WaitTime      = 3           ! 300ms
10560     MaxNoOfWaits = AbortTime / WaitTime
10570     AttemptNo    = 0
10580     Settled      = 1           ! initially assume ok for ED only case.
10590 !
10600 ! make sure the BERT has executed all preceding commands before
10610 ! starting a fixed delay in the controller which is to allow the BERT
10620 ! time to detect the frequency change.
10630 ! Synchronising the controller to the BERT is achieved by any query.
10640     Id$=FNInstrid$( @Bert )
10650     WAIT WaitTime
10660 !
10670     IF FNBertPgPresent( @Bert ) THEN
10680         REPEAT
10690             OUTPUT @Bert;"SENSE6:BAND?"
10700             ENTER @Bert;Band
10710             Settled = FNClkBandok( ActualFreq, Band )
10720             GOSUB AbortOrWait
10730             UNTIL ( Settled OR Abort )
10740             !
10750             IF Settled THEN
10760                 AttemptNo     = 0
10770                 REPEAT
10780                     OUTPUT @Bert;"SENSE6:FREQ?"
10790                     ENTER @Bert;MeasFreq
```

## Program Examples

```
10800             Settled = FNFreqInTol( ActualFreq, MeasFreq )
10810             GOSUB AbortOrWait
10820             UNTIL ( Settled OR Abort )
10830             END IF
10840         END IF
10850     !
10860     IF Settled AND FNBertEdPresent( @Bert ) THEN
10870         AttemptNo = 0
10880         REPEAT
10890             OUTPUT @Bert;"SENSE2:BAND?"
10900             ENTER @Bert;Band
10910             Settled = FNClkBandok( ActualFreq, Band )
10920             GOSUB AbortOrWait
10930             UNTIL ( Settled OR Abort )
10940             !
10950             IF Settled THEN
10960                 AttemptNo = 0
10970                 REPEAT
10980                     OUTPUT @Bert;"SENSE2:FREQ?"
10990                     ENTER @Bert;MeasFreq
11000                     Settled = FNFreqInTol( ActualFreq, MeasFreq )
11010                     GOSUB AbortOrWait
11020                     UNTIL ( Settled OR Abort )
11030                 END IF
11040             END IF
11050         RETURN Settled
11060     !
11070 AbortOrWait:!
11080     IF NOT Settled THEN
11090         AttemptNo=AttemptNo+1
11100         Abort=(AttemptNo>=MaxNoOfWaits)
11110         IF NOT Abort THEN
11120             WAIT WaitTime
11130         END IF
11140     END IF
11150     RETURN
11160     !
11170 FNEND
```

Program Examples  
Testing and Gaining Pattern Synchronization

---

## Testing and Gaining Pattern Synchronization

```
3250 ! determine whether the BERT's error detector has sync'd to the
3260 ! received pattern at the DATA IN port.
3270 !
3280 DEF FNSyncLs(@Bert)
3290   INTEGER QuesCond
3300   OUTPUT @Bert;"STAT:QUES:COND?"
3310   ENTER @Bert;QuesCond
3320   RETURN BIT(QuesCond,10)
3330 FNEND
3340 !
3350 ! determine whether the BERT's error detector has attempted to sync
3360 ! to the received pattern with all possible pattern bit alignment
3370 ! positions.
3380 !
3390 DEF FNFrstSyncCyc(@Bert)
3400   INTEGER QuesCond
3410   OUTPUT @Bert;"STAT:QUES:COND?"
3420   ENTER @Bert;QuesCond
3430   RETURN BIT(QuesCond,12)
3440 FNEND
3450 !
3460 ! determine whether the BERT's error detector is in sync with the
3470 ! received pattern at the DATA IN port.
3480 ! If SyncLs is asserted then re-start a sync search and await SyncLs
3490 ! being deasserted or the completion of sync attempt with all
3500 ! possible pattern bit alignment positions.
3505 ! returns 1 when in-sync
3510 ! returns 0 if SyncLs still true after 1 complete sync search
3515 !
3520 DEF FNGainSync(@Bert)
3540   IF FNSyncLs(@Bert) THEN
3550       OUTPUT @Bert;"SENSE1:SYNC ONCE"           ! start sync search
3560       REPEAT
3570           WAIT .3 ! seconds
3580           UNTIL NOT FMSyncLs(@Bert) OR NOT FNFrstSyncCyc(@Bert)
3590   END IF
3600   RETURN NOT FNSyncLs(@Bert)
3610 FNEND
```

Program Examples  
Performing Clock To Data Delay Alignment

---

## Performing Clock To Data Delay Alignment

```
23810 !           FNAlignEdDelay
23820 !
23830 ! Perform an alignment of the error detector's CLOCK IN
23840 ! with respect to its DATA IN in order position the
23850 ! detector's sampling of the pattern data at the middle
23860 ! of the eye.
23870 ! Return 1 for success and o/p the resultant eye-width and center delay
23880 ! Return 0 for failure (In this case the resultant eye-width and center
23890 !                               delay are Nan.)
23900 !
23910 DEF FNAlignEdDelay( @Bert, REAL EyeEdgeThold, REAL Eye_width,
                        REAL Center_delay )
23920 !
23930 DIM A$(100)                               ! for status text
23940 REAL Ghz,Nan,Sectops
23950 INTEGER Attempt no,Max attempt,Attempt delay,In progress,Success,Abort
23960 !
23970   Attempt delay =2                          ! seconds
23980   Max attempt   =120/Attempt delay ! 2 minutes
23990   EyeEdgeThold  =1.0E-7
24000   Ghz           =1.0E+9                ! conversion constant
24010   Sectops       =1.0E+12               ! conversion constant
24020   Nan           =9.9E+37               ! "Not a number" => failed
24030 !
24040   CALL Seteyeedge(@Bert, EyeEdgeThold)
24050   GOSUB Startalign
24060   GOSUB Doalign
24070   Success = NOT(In progress OR Abort)
24080   IF Success THEN
24090     GOSUB Readeyewidth
24100   ELSE
24110     GOSUB Abortalign
24120   END IF
24130   RETURN Success
24140 !
24150 Startalign:      !
24160   OUTPUT @Bert;"SENSE1:EYE:TCENTER ON"
24170   Attempt_no=0
24180   REPEAT
24190     Attempt no=Attempt no+1
24200     Abort = (Attempt no>=2)
24210   UNTIL (FNAligning OR Abort)
```

## Program Examples

### Performing Clock To Data Delay Alignment

```
24220 IF Abort THEN
24230     DISP "failed to start clk-data alignment."
24240     WAIT 2
24250 END IF
24260 RETURN
24270 !
24280 Doalign:      !
24290     Attempt no=0
24300     REPEAT
24310         Attempt no=Attempt no+1
24320         GOSUB Readeyeinfo
24330         DISP "Status: ";A$
24340         Abort = (Attempt_no>=Max_attempt)
24350         IF NOT Abort THEN
24360             WAIT Attempt_delay
24370         END IF
24380     UNTIL (NOT (FNAligning) OR Abort)
24390 RETURN
24400 !
24410 Abortalign:  !
24420     OUTPUT @Bert;"SENSE1:EYE:TCENTER OFF"
24430     Attempt no=0
24440     REPEAT
24450         Attempt no=Attempt no+1
24460         Abort = (Attempt no>=2)
24470     UNTIL (NOT (FNAligning) OR Abort)
24480     IF (NOT (Abort)) THEN
24490         DISP "clk-data alignment aborted"
24500     ELSE
24510         DISP "failed to abort clk-data alignment."
24520     END IF
24530     WAIT 2
24540 RETURN
24550 !
24560 Readeyewidth: !
24570     OUTPUT @Bert;"SENSE1:EYE:WIDTH?"
24580     ENTER @Bert;Eye_width
24590     IF (Eye_width<Nan) THEN
24600         OUTPUT @Bert;"INPUT1:DELAY?"
24610         ENTER @Bert;Center_delay
24620         Eye_width=Eye_width*Sectops           ! scale to ps
24630         Center_delay=Center_delay*Sectops     ! scale to ps
24640         DISP USING "K,S4D,K,5D,K,2D.D,K";" center ",Center_delay,
" ps width ", Eye_width," ps "
24650     ELSE
24660     ! DISP " ** alignment unsuccessful **"
24670     END IF
```

## Program Examples

### Performing Clock To Data Delay Alignment

```
24680 RETURN
24690 !
24700 Readeyeinfo:      !
24710     OUTPUT @Bert;"SENSE1:EYE:STEXT?"
24720     ENTER @Bert;A$
24730 RETURN
24740 !
24750 FNEND
24760 !
24770 !
24780 DEF FNaligning( @Bert )
24790 INTEGER In_progress,Oper_stat
24800 !   OUTPUT @Bert;"STATUS:OPER:COND?"    ! use "TCENTER?"
24810 !   ENTER @Bert;Oper_stat
24820 !   In_progress=BIT(Oper_stat,11)
24830 OUTPUT @Bert;"SENSE1:EYE:TCENTER?"
24840 ENTER @Bert;In_progress
24850 RETURN In_progress
24860 FNEND
24870 !
24880 SUB Seteyeedge( @Bert, REAL Tholdber)
24890 ! DISP USING "#,K,DESZ";"eye-edge BER ",Tholdber
24900 OUTPUT @Bert; "SENSE1:EYE:THR "&VAL$(Tholdber)
24910 SUBEXIT
24920 SUBEND
```



**A**

Address Configuration, HP-IB 1-5  
Audio Output on Bit Errors 5-47

**B**

Basic, Programming Hint 4-4

**C**

Clock Loss Register Group 3-10  
Clock Stabilization, program example 9-2  
Command Language 2-2  
Command Structure, SCPI 2-4, 2-5  
Command Syntax, SCPI 2-5  
Common Commands 6-16  
Common Commands, SCPI 2-2  
Connecting to the HP-IB 1-4  
Control of User Pattern A to B Changeover  
5-11  
Coupled Parameters, SCPI 2-11

**D**

Definition of Input/Output Ports 6-2  
Device Clear (CLEAR), HP-IB command  
1-7  
Device/Controller Synchronization  
Techniques 2-8

**E**

Error Addition 5-12  
Error Detector  
CLOCK IN 5-29  
clock input port 6-13  
DATA IN 5-26  
data input port 6-10  
Error Location 5-34  
error output port 6-13  
ERRORS OUTPUT 5-30  
Measurement Functions 5-36  
Measurement Gating 5-32  
measurement subsystem 6-14  
Pattern Synchronization 5-31

Result and Configuration Logging  
5-45  
TRIGGER OUTPUT 5-30  
trigger output port 6-13

**F**

Failure Status Register Group 3-11

**H**

Hewlett-Packard Interface Bus (HP-IB) 1-3  
HP-IB  
Non-HP Controllers 1-8  
Required Commands 1-6  
HP-IB command  
Device Clear (CLEAR) 1-7  
Local (LOCAL) 1-7  
Local Lockout (LOCAL LOCKOUT)  
1-7  
Remote Enable (REMOTE) 1-7  
Serial Poll (SPOLL) 1-7

**I**

IEEE  
Common Commands 6-23  
Common Commands and Queries  
5-52  
Mandatory Commands 5-52  
Optional Commands 5-52  
Input/Output Ports, Definition of 6-2  
INST PRESET, hardkey 5-48, 5-53  
Instrument Control Commands, SCPI 2-3  
Instrument Status 5-50  
Interface Types 1-3  
Internal Registers 3-2  
Interrupt Programming 3-17

**L**

Labview, Programming Hints 4-5  
Local (LOCAL), HP-IB command 1-7  
Local Lockout (LOCAL LOCKOUT),  
HP-IB command 1-7  
Local Mode 1-6  
logging, hardkey 5-45

**M**

Mandatory Commands, SCPI 2-3  
Message Format 1-9  
MS-IB 1-3

**N**

Non-HP Controllers, HP-IB 1-8  
Non-SCPI Commands 7-7

**O**

Operation Complete Messages, SCPI 2-9  
Operation Status Register Group 3-15  
Optional Commands, SCPI 2-3, 2-5  
Overlapped Commands, SCPI 2-8

**P**

Pattern Configuration 5-2  
Pattern Generator  
    clock (inverted) output port 6-9  
    CLOCK IN 5-24  
    clock input port 6-8  
    CLOCK OUT 5-18  
    CLOCK OUT (inverted) 5-19  
    clock output port 6-5  
    data (inverted) output port 6-9  
    DATA OUT 5-15  
    DATA OUT (inverted) 5-17  
    data output port 6-3  
    PARALLEL DATA OUTPUTS 5-20  
    SUBRATE CLOCK OUT 5-21  
    subrate data output port 6-7  
    TRIGGER OUTPUT 5-22  
    trigger output port 6-6  
Pattern Upload/Download 4-2  
PatternGenerator  
    subrate clock output port 6-8  
Performing Clock To Data Delay  
    Alignment, program example 9-8  
Power On 1-5  
Preset 1, softkey 5-48  
Preset 2, softkey 5-48  
Program example  
    Clock Stabilization 9-2

Performing Clock To Data Delay  
    Alignment 9-8  
RMB-UX Basic Language Example of  
    the Use of BANDswitch? 9-3  
Testing and Gaining Pattern  
    Synchronization 9-7

Programming Hints

    Basic 4-4  
    Labview 4-5  
    Visual Basic 4-5

**Q**

Questionable Data Status Register Group  
    3-12

**R**

Reading Data 1-8  
recall setup, softkey 5-48  
References, IEEE 488 2-13  
References, SCPI 2-13  
Register Group  
    Clock Loss 3-10  
    Failure Status 3-11  
    Operation Status 3-15  
    Questionable Data Status 3-12  
    Standard Event Status 3-8  
    Status Byte 3-5  
Registers, Internal 3-2  
Remote Enable (REMOTE), HP-IB  
    command 1-7  
Remote Mode 1-6  
RMB-UX Basic Language Example of the  
    Use of BANDswitch?, program  
    example 9-3

**S**

SCPI  
    Approved Commands 7-7  
    Command Separators 2-5  
    Command Structure 2-4, 2-5  
    Command Syntax 2-5  
    Common Commands 2-2  
    Confirmed Commands 7-2  
    Coupled Parameters 2-11

## Index - Programming Manual

- Instrument Control Commands 2-3
- Mandatory Commands 2-3
- Operation Complete Messages 2-9
- Optional Commands 2-3, 2-5
- Overlapped Commands 2-8
- References 2-13
- Sending Commands 2-5
- Sequential Commands 2-9
- Version 7-2
- SCPI messages
  - Command Errors [-199, -100] 8-3
  - Execution Errors [-299, -200] 8-8
  - No Error 8-2
  - Query Errors [-499, -400] 8-14
- Sending Commands, SCPI 2-5
- Sequential Commands, SCPI 2-9
- Serial Poll (SPOLL), HP-IB command 1-7
- Service Request 3-17
- Slaved MMS Clock Source 5-25
- Slaved MMS Signal Generator clock
  - output port 6-22
- Standard Commands for Programmable Instruments (SCPI) 2-2
- Standard Event Status Register Group 3-8
- Status Byte Register Group 3-5
- Status Reporting 3-2
- Synchronization Techniques, Device/
  - Controller 2-8
- System Configuration 1-2
- System Level Status and Control 5-47

### T

- Testing and Gaining Pattern
  - Synchronization, program example 9-7

### U

- Use of the :DATA command 5-7
- Use of the :IDATA command 5-9
- User Pattern Disk Operations 5-13

### V

- Visual Basic, Programming Hints 4-5



# Sales and Service Offices

An up-to-date list of Sales and Service Offices is available through the Website at URL:

**<http://www.agilent.com/find/tmdir>**



